

## Model 3TX-ISE 3-Wire Ion Selective Transmitter

- 3TX-ISE is a transmitter for Ion Selective (ISE) and Temperature Measurement
- Standard module has ranges of 0-10, 0-100 or 0-999 ppm (selectable)
- Special kilo-ppm module with ranges of 0-10,000, 0-100,000 or 0-999,000 ppm
- Ion activity displayed in ppm or kilo-ppm and Temperature displayed in °C
- Support for measurement with any ion selective sensor is possible
- Supports ISE sensors with & without preamplifiers (max 330 feet with preamp)
- Offset calibration for agreement between inline reading with lab & portable grab sample analysis using photometric, optical colorimetric methods
- Slope of Ion Selective (ISE) Sensors can be determined with 2-Point calibration
- Temperature compensation via Platinum 100 or 1000 Ohm element
- Scalable analog 0/4-20 mA output for ion activity in ppm or kilo-ppm units
- Display raw ISE sensor mV input & mA output value for diagnostic purposes
- Galvanic isolation between sensor input, power & analog output (3000V rating)
- Optional: Serial communication via RS-485 MODbus RTU digital output
- Up to 9 measurement channels in single NEMA 4X or IP65 enclosure assembly

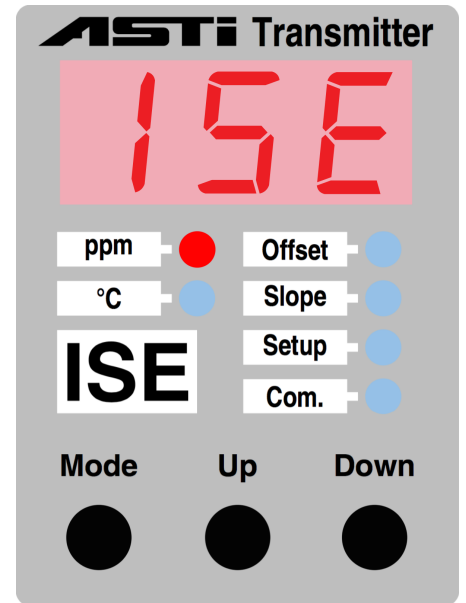

### FEATURES

#### The ASTI 3TX Family of Transmitters Consists Of:

**3TX-pH:** pH, ORP/mV & Temperature Transmitter with fully scalable 0/4-20mA output and MODbus (optional)

**3TX-CON:** Contacting Conductivity Transmitter with fully scalable 0/4-20mA output and MODbus (optional)

**3TX-ISE:** Ion Selective \* (ISE) Transmitter with fully scalable 0/4-20mA output and MODbus (optional)

**3TX-DO:** Dissolved Oxygen Transmitter with fully scalable 0/4-20mA output and MODbus (optional)

**3TX-TEM:** Add scalable 4-20mA output of Temperature to 3TX-pH, 3TX-ISE, 3TX-CON or 3TX-DO transmitter.

**3TX-REL:** Alarm & relay controller (On/Off, TPC, PFC) for pH/ORP, ISE, DO & Conductivity measurements

**3TX-TOT:** Compute pH compensated "Total ISE" from ISE & pH inputs, 0/4-20mA analog & MODbus outputs

**3TX-DAT:** Datalogger & MODbus Master for up to 63 each 3TX transmitter modules with MODbus output

The 3TX family has a 3 digit display and 6 LEDs for setup and displaying values. The 'Mode' key is used to navigate.

#### Programming

The module is programmed by 3 keys on the front panel. The 'Mode' toggles and the 'Up' or 'Down' scroll through parameters. The parameter is altered via the 'Mode' and the value is changed using the 'Up' or 'Down'.

**Parameter P01 "lock" must be set to 'Off' to change ANY parameter, including performing the temperature, offset and slope calibrations.**

\* Ion selective measurement must be validated by ASTI factory prior to order. 3TX-ISE sold only as part of complete ISE system with mating ISE sensor.

#### Input

The ion selective (ISE) sensor without preamplifier is connected directly to 3TX-ISE. The mV signal from these sensors are processed by an integrated high impedance amplifier. The 3TX-ISE-X version supports preamplifiers either integral to the sensor or in external J-Box to enable installations that requiring long cable lengths, snap connectors or to operate in noisy high interference areas. Temperature measurement with a Pt100/Pt1000 allows automatic temperature compensation to be performed.

#### Analog Output

The 3TX-ISE transmitter has a scalable analog output of either 0-20 or 4-20 mA (selectable). Difference between the minimum (0/4mA) and maximum (20mA) output is 20% of selected range (low 0-10, mid 0-100 or high 0-1000). For example, if the low range (0-10) is selected then output could be as narrow as 0-2 for the 0/4-20 mA scaling. The analog current loop output is proportional to ISE ppm and is galvanically isolated from the input (3000V rating).

#### MODbus Output (Optional)

Acquired data is transferred using MODbus standard for multidrop communication and connected using RS485. The Modbus-master may be 3TX-DAT or any SCADA system. When units are ordered with MODbus option, the free of charge Windows datalogging and graphing software and be used to monitor and record all process and temperature values from up to 247 3TX transmitters simultaneously at distances up to 6500 feet (2 kilometers).

## TECHNICAL SPECIFICATIONS

### Mechanical

Housing: Lexan UL94V-0 (Upper part)  
Noryl UL94V-0 (Lower part)  
Mounting: M36 for 35 mm DIN rail  
IP Class: Housing IP40. Connector IP20  
Connector: Max 16A. Max 2.5 mm<sup>2</sup>  
Max torque 0,6 Nm  
Temp.: Usage -15 to +50 °C (Storage -35 to +75 °C)  
Weight: 75 grams (2.64 ounces)  
Dimensions: D 58 x W 36 x H 86 mm (2.3" X 1.4" X 3.4")  
CE mark: EN61326A



### Electrical

Power Supply: 24VDC ±10%  
Consumption: 60 mA max  
Sensor: Combination Ion Selective Sensor  
3TX-ISE Ranges: 0-10, 0-100, 0-999 ppm or  
Special Order 0-10,000, 0-100,000 or 0-999,000 ppm  
3TX-ISE-kilo: (a.ka. 0-10, 0-100, 0-999 kilo-ppm)  
mV Input Range: ±1000mV  
ISE input: < 1pA, >10GΩ  
Accuracy: ±0.2% Excluding Sensor (Ideal)  
Temp Sensor: Pt100 or Pt1000  
Temp Range: 0-150°C ± 0.3°C  
Temperature Fixed (Manual) or Automatic using  
Compensation: Temperature (TC) Measurement  
Analog Output: 0-20mA or 4-20mA, max. 500Ω

## PARAMETERS

### Function and Programming

The 21 programmable parameters are shown to the right. For access see the paragraph about programming on page 1.

**If the softwarelock (Par. no. 1) is "On" the parameter can only be read. Set Software Lock to "Off" to change values.**

**Par. no. 2** sets address for MODbus communication.

**Par. no. 3** indicates the type of temperature element input.

**Par. no. 4** sets the temperature compensation to either set (manual) type or automatic based on measured temperature.

**Par. no. 5** sets the temperature for when temperature compensation of the ISE sensor is in fixed (manual) mode.

**Par. no. 6** If long cable run is used with Pt100 TC then cable impedance is entered and subtracted from measured value.

**Par. no. 7** Selects the output to be either ISE or temperature.

**Par. no. 8** sets analog output to either 0-20 mA or 4-20 mA.

**Par. no. 9** sets the analog output scaling to either low (0.00-9.99 ppm), mid (00.0-99.9 ppm) or high (000-999 ppm) range.

**Par. no. 10 & 11** set the ppm or kilo-ppm values that corresponds to 0/4mA output setpoint (**Par no. 10**) and sets the ppm value that corresponds to 20mA output setpoint (**Par no. 11**). The difference between Par no. 10 and 11 must be at least 20% of the selected low, mid or high range. Please note that the display and output ranges are altogether decoupled.

**Par. no. 12** Variable to define the mV change for each "Up" or "Down" button depression when calibration is performed.

**Par. no. 13** Displays formula weight of measured ion. Next page has details on how to determine ion type from this value

**Par. no. 14** View and edit the working (effective) sensor offset

**Par. no. 15** View and edit the working (effective) sensor slope

**Par. no. 16** Offset adjustment for low 0/4mA output trim.

**Par. no. 17** Gain adjustment for 20mA high output trim.

**Par. no. 18** If no keys are pressed for 10 min the display will show flashing bar (Energy Save). Press any key to return.

**Par. no. 19** The MODbus standard requires a baudrate of 9,600 or 19,200 set in accordance with the MODbus-master.

**Par. no. 20** Resets (reverts) all settings on the transmitter back to default values for the given factory configuration.

**Par. no. 21** Feature to reset ONLY the sensor offset and slope calibrations back to the factory default values.

### List of Parameters

No	Parameter	Description	Range	Default
01	Lock	Software Lock	On / Off	On
02	Address	MODbus Node	Off, 1...247	Off
03	Temperature	Type of Input	Pt100, Pt1000	Pt1000
04	Compensation	Temp. Comp. of ISE Sensor	Auto, Set (Manual)	Auto
05	Comp. Temp.	Compensating Temperature	0..150	25
06	Cable Impedance	Impedance of Pt100 Cable	0.0 .. 9.9 Ohm	0.0
07	Output Variable	ISE or Temperature	ISE, °C	ISE
08	Analog Output Range	ISE Output Range	0-20, 4-20	4-20
09	kilo-ppm or ppm Range	Lo 0-10, Mi 0-100 or Hi 0-999	10.0, 100, 999	10.0
10	0/4mA Set	Low Setpoint	0.00..999	0.00
11	20mA Set	High Setpoint	0.00..999	10.0
12	Step Change	mV Increment per 'Up' or 'Down' Button Depression	0=0.02, 1=0.05, 2=0.10, 3=0.20, 4=0.5, 5=1.0, 6=2.0	2 (0.10mV)
13	View Formula Weight of Ion	Grams per Mol of Ion	XX.XX per Ion Weight	N/A
14	View Current Sensor Offset	mV at Isoconcentration	Per ISE Sensor *	N/A
15	View Current Sensor Slope	mV per Decade Response	Per ISE Sensor *	N/A
16	0/4mA Offset	Trim Low	±9.99% *	0.00
17	20mA Gain	Trim High	±9.99% *	0.00
18	Energy Save	Energy Save	On / Off	Off
19	Baudrate	MODbus	9,600 / 19,200	19,200
20	Reset All Back to Default	Revert all to Factory Default	Def=Reset, Par=NoReset	Par
21	Reset Cal values only	Revert all Calibrations	Def=Reset, Par=NoReset	Par

\* Negative numbers will be shown as flashing.

## Offset / Slope Adjustment

Calibration of the ion selective sensor is done with Up/Down keys. To perform a 2-point slope calibration use 'Mode' key select 'Offset' and adjust the reading until the display shows the correct value for the first ISE standard. Next select 'Slope' and use the Up/Down keys until the display reads the second desired value for the second ISE standard. A production 'Offset' calibration (for agreement with grab sample analysis) is done without performing slope calibration. **The ISE sensor should be left in service for the production 1-point 'Offset' calibration.** All settings are stored in EEPROM so unit can be powered down without loss of configuration or calibration.

Wiring for ISE sensors with & without preamplifiers are detailed to the right. These two wiring details represent interface with two altogether different hardware versions which must be selected at time of purchase.

## Typical Installation

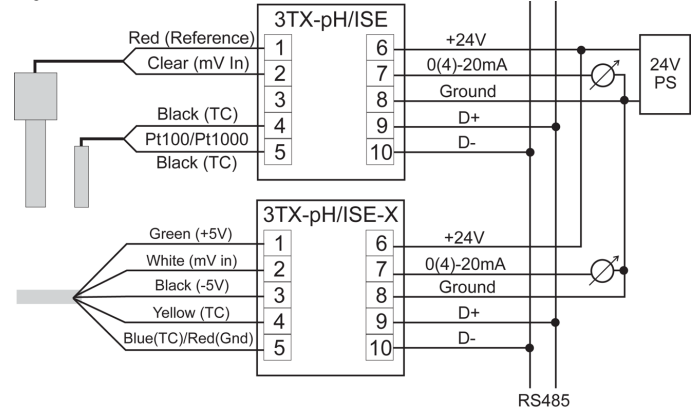

**TABLE TO DETERMINE SELECTED ISE TRANSMITTER TYPES**

Value of Parameter 13 (Formula Weight of Ion)	Corresponding Ion Selective Analyzer Type (Fixed)	Value of Parameter 13 (Formula Weight of Ion)	Corresponding Ion Selective Analyzer Type (Fixed)
18.04	NH <sub>4</sub> <sup>+</sup> (Ammonium)	19.00	F <sup>-</sup> (Fluoride)
40.08	Ca <sup>++</sup> (Calcium)	35.45	Cl <sup>-</sup> (Chloride)
23.00	Na <sup>+</sup> (Sodium)	62.00	NO <sub>3</sub> <sup>-</sup> (Nitrate)
6.94	Li <sup>+</sup> (Lithium)	26.02	CN <sup>-</sup> (Cyanide)

Sign of sensor slope is fixed based upon ion type (anion or cation). Configuration of 3TX-ISE modules is done at factory and cannot be modified in the field. Contact factory for any values not listed above to determine the measurement type from the parameter 13 (Formula Weight of Ion).

## DISPLAY FEATURES & NOTES:

- Raw (absolute) mV potential of sensor displayed with "Down" key in the ppm mode. Negative mV values displayed as flashing.
- The mA output based upon the current reading and scaling can be displayed with "Up" key in ppm mode.
- Temperature is calibrated by pushing "Up" or "Down" buttons when in the temperature display (°C) mode (P01 must be "Off").
- Offset display by pressing "Down" in 'Offset' mode & slope is displayed by pressing "Down" in 'Slope' mode (P01 must be "On").

## MODBUS

To utilize MODbus interface 3TX-ISE must be ordered with MODbus. 3TX-ISE may be used as a slave for the 3TX-DAT or as a slave in a SCADA data acquisition. The setup and communication for each case will be explained below.

### With 3TX-DAT

If 3TX-ISE used with 3TX-DAT, note baud rate and node address. **The baud rate (P19) on 3TX-ISE must match baud rate of 3TX-DAT.** Whether baud rate of 19,200 or 9,600 is used is not important, as long as all units are set to same baud rate.

**The address (P02) must be unique in the network;** Two units cannot have the same address. In network with 3TX-DAT as the master, all addresses must be assigned in series. In a network with a 3TX-DAT, up to 63 slaves may be connected.

### In SCADA system or with Windows Datalogging software

Since different SCADA systems may have other restrictions only the general points are mentioned here: **The baud rate (P19) must match baud rate of the SCADA system. The address (P02) must be unique in the network.** Up to 247 3TX transmitters may be connected on a single network; repeaters may be required if more than 32 nodes are used and/or for long cable distances (max 6500 feet / 2 kilometers).

### MODbus Scaling

The MODbus scaling is defined only by P09 (low, mid or high) and may differ from 0/4-20 mA analog scaling defined by P10 & P11. Display limits are decoupled from outputs.

The 3TX-ISE contains 2 measurements (ISE and temperature). Access to these are gained through the function code *Read\_Input\_Registers (04)*. The 3TX-ISE gives access to different diagnostic values via *Diagnostics (08)*, as shown below.

### Read\_Input\_Registers

Function code	Start address	Number of values
<b>04</b>	<b>1</b>	<b>1 or 2</b>

Value 1 is ISE ppm or kilo-ppm and value 2 is temperature. The measurements are transmitted in sequence; If 2 values are chosen both ISE ppm or kilo-ppm and temperature are transmitted. If the value for temperature is wanted, 2 values must be requested. Both values are rated to 0-1000 corresponding to the range, but the temperature has an offset of 1024; for example 0-100 ppm is transmitted as 0-1000 and 0-150 °C is sent as 1024- 2024.

### Diagnostics

Function Code	Sub Code (HEX)	Description
08	00	Return Query Data
	0A	Clear counters and diagnostics register
	0B	Return Bus Message Count
	0C	Return Bus Communication Error count
	0D	Return Exception Error count
	0E	Return Slave Message count
	0F	Return Slave No Response count
	12	Return Bus Character Overrun count



**ORDERING INFORMATION FOR 3TX FAMILY OF TRANSMITTERS**

ENCLOSURE TYPE	
CODE	DESCRIPTION
3TX-0M	3TX Transmitter with No Enclosure
3TX-DIN	3TX Transmitter with No Enclosure; Preinstalled onto 35mm DIN-Rail
3TX-2MW	3TX Transmitter(s) with IP65 WeatherProof Enclosure; Up to 2 Total Modules ( <b>Wall Installations Only</b> )
3TX-2M	3TX Transmitter(s) with IP65 WeatherProof Enclosure; Up to 2 Total Modules (Wall or Pipe Installations)
3TX-3MP	3TX Transmitter(s) with NEMA 4X Enclosure for ½-DIN <b>Panel Only</b> ; Up to 3 Modules ( <b>with Panel Bracket Assembly</b> )
3TX-3MF	3TX Transmitter(s) with NEMA 4X Enclosure; Up to 3 Total Modules (Wall or Pipe Installations)
3TX-4MW	3TX Transmitter(s) with IP65 WeatherProof Enclosure; Up to 4 Total Modules ( <b>Wall Installations Only</b> )
3TX-4M	3TX Transmitter(s) with IP65 WeatherProof Enclosure; Up to 4 Total Modules (Wall or Pipe Installations)
3TX-5MF	3TX Transmitter(s) with NEMA 4X Enclosure; Up to 5 Total Modules (Wall or Pipe Installations)
3TX-6M ***	3TX Transmitter(s) with IP65 WeatherProof Enclosure; Up to 6 Total Modules (Wall or Pipe Installations)
3TX-7MF ***	3TX Transmitter(s) with NEMA 4X Enclosure; Up to 7 Total Modules (Wall or Pipe Installations)
3TX-9MF ***	3TX Transmitter(s) with NEMA 4X Enclosure; Up to 9 Total Modules (Wall or Pipe Installations)
MEASUREMENT MODULES ONE (1) THROUGH SEVEN (7)	
CODE	DESCRIPTION
-pH *	pH/ORP/mV/Temp Measurement Module / Transmitter
-HiQ-pH	Intelligent pH & ORP Transmitter for Smart Digital pH & ORP Sensors; <b>Both 4-20mA &amp; MODBUS outputs standard</b>
-CON-CELL/RANGE	Contacting Conductivity Measurement Module / Transmitter ( <b>CELL</b> Constant & <b>RANGE</b> Defined at Time of Order)
-ISE-ION *	Ion Selective (ISE) Measurement Module / Transmitter for ppm ranges **
-ISE-kilo-ION *	Ion Selective (ISE) Measurement Transmitter for kilo-ppm ranges ** <b>Both 4-20mA &amp; MODBUS outputs are standard</b>
-DO	Dissolved Oxygen Measurement Module / Transmitter For Galvanic Type DO sensors
OUTPUT OPTIONS FOR MEASUREMENT MODULES (ONE OPTION MUST BE SELECTED FOR EACH MODULE)	
CODE	DESCRIPTION
-A	Single Fully Scalable Analog 0-20 or 4-20 mA Output Only
-D	Single Fully Scalable Analog 0-20 or 4-20 mA Output Only AND RS-485 MODbus Digital Output
ADD-ON MODULES FOR MEASUREMENT MODULE ENCLOSURE ASSEMBLIES	
CODE	DESCRIPTION
-PS	100 to 240 VAC 50/60 Hz Universal Power Supply Adapter for Line Powered Operation
-PS/BAT	Dual Isolated & Regulated 24VDC Power Supply Step-Up Converter for operation from 5V, 6V & 9V Batteries
-TEM	Scalable Analog 0-20 or 4-20mA Temperature Transmitter for Raw or Spliced Pt100/Pt1000 temperature element
-SW	On/Off Power Switch (½ Width of power supply module and ¼ width of standard 3TX transmitter)
-REL	Alarm and Relay Controller Module for 3TX-pH, 3TX-ISE, 3TX-CON and 3TX-DO measurement modules
-TOT	Compute pH compensated "Total ISE" from analog inputs for ISE & pH, 0/4-20mA analog & MODbus digital outputs
-DAT	Datalogger & MODbusmaster for 3TX Transmitters with RS485 MODbus; Download & Setup via RS232/USB Port

Contact the factory for specific recommendations & ALL ISE inquiries. Pipe mounting bracket kits supplied separately. For 3MP, 3MF, 6M & 7MF enclosures power supply is not counted as a module for space purposes.

**Model: 3TX-5MF-ISE-kilo-NH4-X-HiQ-pH-TOT-DAT-PS**

Description: High-Range kilo-ppm Total Ammonium (pH compensated), Free Ammonioium & pH Measurement & Datalogging System; scalable 4-20mA analog output and RS-485 MODBUS RTU digital outputs for each measured parameter; NEMA 4X enclosure assembly with 85-265 VAC universal power supply for AC line powered operation

**Model: 3TX-3MP-ISE-F-A-pH-A-TOT-PS**

Description: Dual Channel Total Fluoride Measurement Transmitter Assembly with NEMA 4X (UL) Enclosure for ½-DIN Panel Mounting Installations (for 3 Total Modules); 1 each ISE Fluoride Ion and 1 each pH Measurement Module with Analog Output Only; 1 each TOT module to compute total fluoride (HF + F-) with Analog & MODbus Outputs for all free fluoride, total fluoride, pH and temperature; With Universal 11 Power Supply Module

**Model: 3TX-3MF-DO-D-TEM-SW-PS**

Description: Dissolve Oxygen Transmitter Assembly with NEMA 4X CSA/UL rated Enclosure; Field or Wall Mounting Installations (3 Module Max); 1 each DO transmitter for galvanic type dissolved oxygen sensors; Scalable Analog & MODbus Output for DO ppm, saturation & Temperature; 115/230 Power Supply with On/Off Switch

**Model: 3TX-4MW-ISE-NH4-A-pH-A-TOT-PS**

Description: Dual Channel Total Ammonia Measurement Transmitter Assembly; Weatherproof Wall Mount Only Enclosure (4 Modules Max); 1 each ISE Ammonium Ion and 1 each pH Measurement Module with Analog Output Only; 1 each TOT to compute total ammonia (NH<sub>3</sub>) with Analog & MODbus Outputs; With 115/230 Power Supply

**Model: 3TX-6M-ISE-NH4-A-pH-A-TOT-ISE-NO2-A-pH-D-DO-D-PS**

Description: Five Channel Transmitter Assembly with Weatherproof Enclosure (for 6 Total Modules); 1 each ISE Ammonium Ion and 1 each pH Measurement Module with Analog Output Only; 1 each TOT module to compute total ammonia (NH<sub>3</sub>) with Analog & MODbus Outputs; 1 each ISE Nitrite Ion with Analog Output Only; 1 each ORP Measurement Module and 1 each DO transmitter for galvanic active self-polarizing type sensors both with Scalable Analog & MODbus Outputs; With 115/230 Power Supply

**Model: 3TX-6M-ISE-X-F-D-REL-pH-X-D-REL-CON-10.0/500-D-DAT-PS**

Description: Triple Channel Transmitter Assembly with Weatherproof Enclosure (for 6 Total Modules Max); 1 each Preamp Style Fluoride ISE Measurement Module & 1 each Preamp Style pH Measurement Module with Alarm/Relay Controller for both Fluoride ISE & pH; 1 each Contacting Conductivity Measurement with K=10.0/cm & Full Range 0-500mS; Analog & MODbus Outputs for All Measurements; DAT Datalogger/MODbusmaster Module to record all parameters; Universal 115/230 Power Supply

**Model: 3TX-7MF-ISE-NH4-D-ISE-NO3-D-ISE-NO2-D-pH-D-CON-1.0/50-D-DO-D-DAT**

Description: Six Channel Measuring Transmitter Assembly Optimized for Low-Power Battery Operation; with NEMA 4X CSA/UL rated Enclosure (7 Module Max); 1 each ISE Ammonium Ion, 1 each ISE Nitrate Ion and 1 each ISE Nitrite Ion Module; 1 each pH module; 1 each Contacting Conductivity K= 1.0/cm & Full Range 0-50mS; 1 each Dissolved Oxygen module; Analog & MODbus Outputs for all Measurements & Temp; DAT Datalogger/MODbusmaster for continuous datalogging of all parameters

\* To obtain a 3TX transmitter that supports and requires analog sensors with preamplifiers, order the pH/ORP transmitters as -pH-X and the ion selective (ISE) transmitters as -ISE-X or -ISE-kilo-X

\*\* The type of ion to be measured must be defined at time of order and cannot be changed after dispatch from the factory.

\*\*\* For 2" NPT pipe mounting installations, an additional adapter plate must also be ordered for the 6M, 7MF & 9MF enclosures (inquire to factory for details).