

Sanitary pH Sensors & ORP Sensors for Tri Clover Installations Requiring Chemical Clean-In-Place (CIP) Sterilization

Unique solutions for process measurement problems. Features & options itemized below:

- Best reference service lifetime in process industry through proprietary, novel, non-porous, cross-linked, conductive polymer technology; Available in double junction (standard) or triple junction (optional “TJ”) configurations
- Rugged industrial grade sensors can operate in a temperature range from -35 to 150 degrees Celsius at pressures up to 200 psig
- Base models for general purpose, high temperature resistant, ultra-high temperature resistant, slurry & viscous material resistant, acid/fluoride & HF resistant, pulp & paper resistant, aggressive dissolved gas & volatile organic solvent resistant, Oxidation Reduction Potential (ORP) and saturated sodium (brine) resistant
- Selected optional features include Ammonia gas resistant (“A”), Chlorine gas resistant (“C”), Wide Range -0.5 to +14.5 pH Media Resistant (“V”), Organic Media Resistant (“L”), Solvent Resistant (“TS”), 3-Wire TC (“M”), ACCU-TEMP Fast TC (“X”), Add Protective Tines 4 ea (“GR”), Add Protective Tines 2 ea (“GRO”), Shielded Preamp Cable (“BL”)
- Available with integral TC (Pt100/Pt1000 Standard), Solution Ground Liquid Earth (316SS or Platinum), Dual pH/ORP All-In-One Configuration and Conventional or Differential Analog preamplifier to allow for interfacing with most any existing OEM transmitter
- End of cable terminations include tinned leads, BNC connector for pH sensors and ORP sensors without integral preamplifier. Quick disconnect snap connector options are available for pH sensors and ORP sensors with integral preamplifiers.
- Convenient Quick-Disconnect Tri-Clover fittings allows easy calibration and cleaning in any process
- 316SS Sanitary Sensor Fitting available in 1.5", 2.0" or 2.5" Tri-Clover sizes (other larger sizes available upon request)
- Alternate fittings can be welded upon request such as 1.25" MNPT threaded nipple for high-pressure inline screw-in installations
- Double sealing O-rings ensure watertight seal Viton®-75 is standard with CV75, Simriz® 485 and Kalrez® 4079 Optional
- Back of sensor sealed with watertight cable gland to ensure watertight operation from washdowns, moisture and outside installations
- Each standard sensor selection and/or special sensor design are based upon customer application information
- pH sensors & ORP sensors are manufactured with rugged RADEL® (Poly-Phenyl-Sulfone, PPSU), KETASPIRE® (Poly-Ether-Ether-Ketone, PEEK) or RYTON® (Poly-Phenylene-Sulfone, PPS) for sensor body housing material of construction
- Solid state reference highly resistant to dehydration. Thick wall glass is nearly impervious to cracking even under pressure.
- Rugged parabolic thick-wall, low-profile, break-resistant pH glass is now standard for all X3XX series pH sensors.
- Extreme Dehydration Resistant Option can be invoked with Alpha Prefix “E” on supported sensor models to allow for intermittent wet and dry operation as well as to support periods of exposure to prolonged dryness in the field or shelf



Close-up of 5X31 sanitary pH sensor with “GR” Tines & O-rings installed



Close-up of 5831 sanitary ORP sensor with “GR” Tines & O-rings installed



Replacement pH & ORP Sensors For Transmitters that support and/or require Integrated Preamplifiers

The instruments listed below require and/or support integral preamplifiers. Sensors to mate with these OEM pH & ORP transmitters are supplied with the appropriate integrated temperature compensation element, solution ground & OEM compatible high-impedance CMOS operational amplifier (a.k.a. preamplifier) as may be required to ensure full compatibility and optimal performance. Some manufacturers and analyzer models can support both sensors with or without preamplifiers on the same instrument. A sensor hook-up schematics for interfacing to the given OEM pH/ORP transmitter is supplied with each sensor, and some of the most common wiring schematic are posted on our website (please inquire for any not listed).

Replacement pH & ORP Sensors For Transmitters DO NOT SUPPORT Integrated Preamplifiers

The instruments listed below do no support preamplifiers. Sensors to mate with these OEM pH & ORP transmitters are supplied with the appropriate internal temperature compensation and/or solution ground signals to ensure compatibility. A sensor hook-up schematics for interfacing to the given OEM pH/ORP transmitter is supplied with each sensor, and the some of the most common wiring schematic are posted on our website (please inquire for any not listed). If longer cable runs may be required for your planned installation, it is recommended to select a transmitter that supports preamplifiers (see list to the left).

Fully Supported Hardware - FULL COMPATIBILITY

Fully Supported Hardware - FULL COMPATIBILITY

Manufacturer	pH & ORP Transmitters	OEM pH & ORP Sensors *
Rosemount Analytical Liquid Division A Part of Emerson Process Management	LEGACY: 1000, 1001, 1002, 1003, 1050, 1181, 1055, 2081, 3081, 81, 54pH, 54epH, XMT MODERN: 1056, 1057, 56, 1066, 5081, 6081	385/385+, 389, 3900 pH & ORP sensors 3300HT, 3400HT & 3500P PERpH-X™ pH & ORP sensors 397, 398/398R, TF396 TUpH™ pH & ORP sensors
Foxboro Analytical EChem by Schneider Electric (a Division of Invensys)	LEGACY: 870IT MODERN: 875PH, 876PH, 873PH, 873DPX	PH10 DolpHin™ pH sensors, ORP10 DolpHin™ ORP sensors, 871A & 871PH pH & ORP sensors, EP460 & EP466 pH & ORP sensors
Honeywell (formerly Leeds and Northrup, a.k.a. L&N)	LEGACY: 7030, 7075, 7076, 7079, 7081, 7082, 7083, 7084, 7096, 9782 MODERN: UDA2182, APT2000PH, APT4000PH	7773, 7774/7774D, 7777/7777D/7777DVP, 7794DVP Sanitary DURAFET™, HB/HB546, HB/HBD547, HB/HB551
Electro-Chemical Devices (a.k.a. ECD)	LEGACY: T20, T21, T27, T29, T30, C22 MODERN: T23, T28	S10 (PHS10) and S17 (PHS17)

Manufacturer	pH & ORP Transmitters	OEM pH & ORP Sensors *
Endress+Hauser (a.k.a. E+H)	LEGACY: CPM152, CPM280, CPM431 MODERN: CPM153, CPM223, CPM253	Inquire to ASTI Factory for alternatives to E+H pH & ORP sensors
Mettler-Toledo International (formerly Ingold)	LEGACY: 1120, 1140, 2050, 2100, 2220, 2400, 2500, 2800X, 2050e, pH 2100e MODERN: M200, M300, M400, M700, M800	Inquire to ASTI Factory for alternatives to Mettler-Toledo pH & ORP sensors
ABB (formerly TBI-Bailey)	LEGACY: TB515, TBN580, TB701/702, 4630, 4631, 4635, 4636, AX416, AX436, AX468, AX460, AX466 MODERN: AX460, AX416, AX436, APA592, TB82pH, TB84pH,	AP100, AP200, AP300, TB(X)551, TB(X)556, TB(X)557, TB(X)561, TB(X)567, TB(X)587
Knick	LEGACY: 2402 MODERN: Stratos Evo, Stratos Pro A2 pH, Stratos Pro A4 pH, Stratos Eco 2405 pH, Stratos 2221 pH, Stratos Stratos 2231 pH, Protos 3400(X)-035, PHU 3400(X)-110	Inquire to ASTI Factory for alternatives to Knick pH & ORP sensors



IOTRON™

pH / ORP / ISE / DO / Conductivity Measurement Products Lines

Supported Hardware with Known Issues -

LIMITED COMPATIBILITY

Manufacturer	pH & ORP Transmitters	OEM pH & ORP Sensors *
Rosemount Analytical Liquid Division A Part of Emerson Process Management	LEGACY: 1054, 1054A, 1054B, 1055	385/385+, 389, 3900 pH & ORP sensors 3300HT, 3400HT & 3500P PERpH-X™ pH & ORP sensors 397, 398/398R, TF396 TUpH™ pH & ORP sensors

HACH (formerly Great Lakes Instruments, a.k.a. GLI)	LEGACY: 33, 53, 60, 62, 63, 70, 83, 90, 95, 570, 670, 671, 690, 691, 692, P33, P53, P63 MODERN: si792, si794, PRO-P3 GLI PRO series, sc200	Encap Diff pH Sensors: Such as 6028P0, 6028P020, 6028P050, 6028P033, 6058P0, 6022P0... 3/4 in Combination pH/ORP Sensors: Such as PC1R1A, RC1R5N, PC1R2A, PC1R1N, PC1R3A, PC1R1A-V12... Analog Differential pH/ORP Sensors: Such as PD1P1, PD1R1, PD2P1, PD1R3, PD1P3, PD3P1, PD2P1A30, PD2P1A50, ...
--	---	--

GF (Georg Fischer) Signet a.k.a +GF+	LEGACY: 710, 2720, 9030, 9040, 8710, 5700 MODERN: 9900, 8900, 8750	2724-2726 pH/ORP Electrodes, 2734-2736 pH/ORP Electrodes, 2774-2777 Threaded DryLoc pH/ORP Electrodes, 2764-2767 Differential DryLoc pH/ORP Electrodes, 3719 pH/ORP Wet-Tap, 2714-2717 pH/ORP Electrodes
---	---	--

* ASTI offers pH & ORP sensors compatible with the transmitters listed above as an alternative to mating OEM pH & ORP sensors detailed.

Trademarks (indicated with ™) are registered to the respective corporations as listed above.

Supported Hardware with Known Issues -

LIMITED COMPATIBILITY

Manufacturer	pH & ORP Transmitters	OEM pH & ORP Sensors *
Yokogawa Electric Corporation (Formerly Johnson Yokogawa Controls, a.k.a. JYC)	LEGACY: pH/ORP 200, pH/ORP 400, pH/ORP 202, pH/ORP 402, pH150, pH100, OR100 MODERN: PH450G, PH202G	FU20 pH/ORP Combined Sensor, PH8EFP, PH8ERP, OR8EFG, OR8ERG pH/ORP Sensors

Most of the pH/ORP transmitter models listed also have a both contacting conductivity and toroidal (inductive contactless) conductivity transmitter counterpart to which ASTI can also supply alternative sensors to the OEM model sensors. Please inquire for any such conductivity retrofit and replacement sensor needs as well as for the pH & ORP measurements.

The manufacturers and models detailed on this webpage are not a complete listing of the supported OEM pH & ORP transmitters, analyzers and controllers to which ASTI can retrofit our replacement pH, ORP and conductivity sensors.

PLEASE INQUIRE ABOUT COMPATIBILITY FOR ANY INSTRUMENTATION NOT LISTED HERE

Naturally, all of the ASTI pH, ORP and Ion selective (ISE) sensors are compatible with our own **2TX, 3TX and 4TX series transmitters**



STANDARD APPLICATIONS

- Acid/Fluoride
- High / Ultra High Temperature
- Paper/Pulp
- Slurry/Viscous Materials
- Saturated Sodium
- Oxidation Reduction Potential
- Sulfides
- Ultrapure Water
- General Purpose

Special Applications

- Organic Solvents Resistant
- Cyanide Resistant
- Dissolved Gases:
- Cl₂, ClO₂, NH₃, SO₂ / SO₃ / NO_x Resistant

LIMITS & CAPABILITIES (PARTIAL LIST)

pH & ORP MEASUREMENTS

- Fluorides up to 50,000 PPM and -0.5 pH
- Sulfides up to Saturation
- Cyanides up to 500 PPM
- High pH range up to 14.5 (with ASTI calibration procedures and buffers)
- Low pH range up to -0.5 (with ASTI calibration procedures and buffers)
- Low Temperature up to -30 °C
- High Temperature up to 150 °C
- High Pressure up to 150 p.s.i.
- Solids Content up to 12% Consistency Pulp
- Almost All Organic Chemical Mixtures (Minimum 1-2 % aqueous content)
- ORP Measurements in Completely Non-Aqueous Medium
- Bleaching Applications using Chlorine and Chlorine Dioxide
- Sterilization Applications using Peroxide, Ozone & Dissolved O₂

PLEASE INQUIRE FOR ANY APPLICATIONS NOT LISTED HERE

1.5", 2.0" & 2.5" Tri-Clover Sanitary Configurations (316SS)



Complete sanitary ORP sensor assembly including protective tines on a 2" TRI-CLOVER type flange

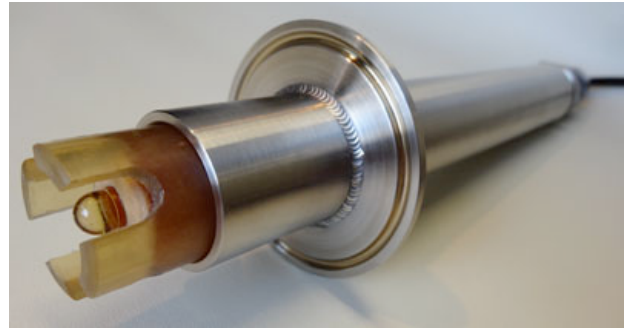

Complete sanitary pH sensor assembly including protective tines on a 2" TRI-CLOVER type flange

Inquire to ASTI factory for process compatibility information for both sanitary sensor holder and sensor materials of construction prior to purchase.



1.5", 2.0" & 2.5" 316SS Tri-Clover Sanitary Sensor Holders with sealing gland assembly, Rear/Side View



1.5", 2.0" & 2.5" 316SS Tri-Clover Sanitary Sensor Holders, Front View

Sensor Bodies for 5XX1 Series Sanitary pH Sensors & ORP Sensors

5X31 Sensor Bodies - RADEL®
Poly-Phenyl-Sulfone, PPSU

5X41 Sensor Bodies - KETASPIRE®
Poly-Ether-Ether-Ketone, PEEK

5X51 Sensor Bodies - RYTON®
Poly-Phenylene-Sulfone, PPS

® RADEL, KETASPIRE and RYTON are registered trademarks of Solvay

1

2

3

REVISION HISTORY		
REV	DESCRIPTION	DATE

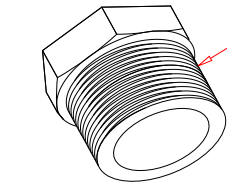

1-1/4" NPT
MOUNTING

2 1/2"

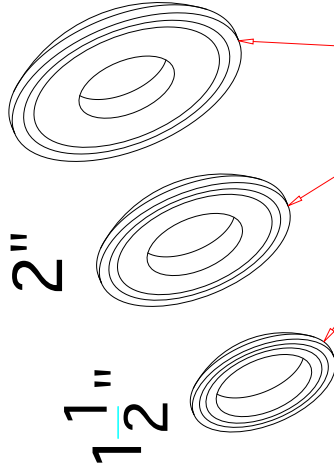

SANITARY FLANGE

MOUNTING OPTIONS

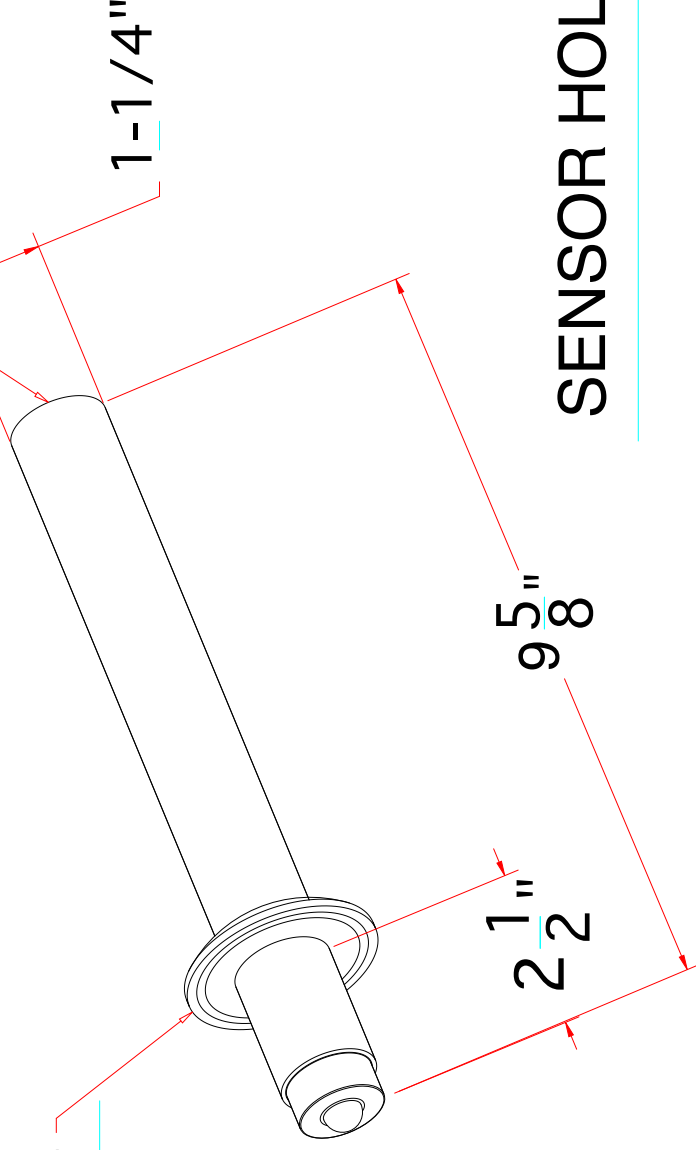

FEMALE 3/4" NPT

1-1/4"

2 1/2"

9 5/8"

SENSOR HOLDER

A

B

NOTES

- All dimensions are in inches, unless otherwise indicated
- Material of construction is 316L Stainless Steel, others upon request
- Insertion depth past welded fitting for sensors without protective tines is 2.8 inches maximum while insertion depth for sensors with protective tines is 2.5 inches maximum.
- While the insertion depth as described in note # 3 is standard, custom insertion depths are available upon request by modifying the location of the welded fitting (inquire to factory)
- Waterproof sealing assembly on back of sensor holder is not shown above. This consists of a 316L SS 3/4"x1/2" NPT reducer busing with 1/2" MNPT sealing cable gland. This waterproof sealing assy adds about 3 inches to the overall holder length.
- When sensor holder is to be for valve retractable HOT-TAP installation use, no fitting is welded at all.
- Only use with ASTI 5X31, 5X41 & 5XX0 series sensors. See installation procedures for proper insertion.

Advanced Sensor Technologies, Inc.
Orange, California USA
Toll-Free: 888-969-2784



TITLE		Sensor Holder for Sanitary & HOT-TAP Use	
SIZE	PROJECT	DRAWING NO.	REV
B	SAN / VR	Sensor Holder Universal	/
SCALE	MODEL	SHEET	OF
Not to Scale	Various	1	1

2

1

3



Sanitary Sensor Selection Guide

Sensors for Sanitary Tri-Clover Installations that
Require Chemical Clean-In-Place (CIP) Sterilization

Short Description of pH/ORP Sensor Series <i>KYNAR Junction used in all 5XX1 Sensors</i>	Sensor Body Housing RADEL® Poly-Phenyl-Sulfone PPSU	Sensor Body Housing KETASPIRE® Poly-Ether-Ether-Ketone PEEK	Sensor Body Housing RYTON® Poly-Phenylene-Sulfone PPS
<i>General Purpose</i>	5031	5041	5051
<i>High Temperature Resistant</i>	5131	5141	5151
<i>Ultra High Temperature Resistant</i>	5231	5241	N/A
<i>Slurry & Viscous Material Resistant</i>	5331	5341	5351
<i>Acid, Fluoride & HF Resistant</i>	5431	5441	5451
<i>Paper & Pulp Resistant</i>	5531	5541	5541
<i>Sulfide Resistant</i>	5631	5641	5651
<i>Aggressive Dissolved Gas & Volatile Organic Solvent Resistant</i>	5731	5741	N/A
<i>Oxidation Reduction Potential a.k.a. ORP</i>	5831	5841	5851
<i>Saturated Sodium (Brine) Resistant</i>	5931	5941	5951

® RADEL, KETASPIRE and RYTON are registered trademarks of Solvay

1

2

3

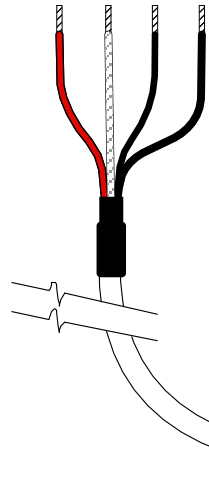

For end of cable terminations and wiring detail please see spec sheet

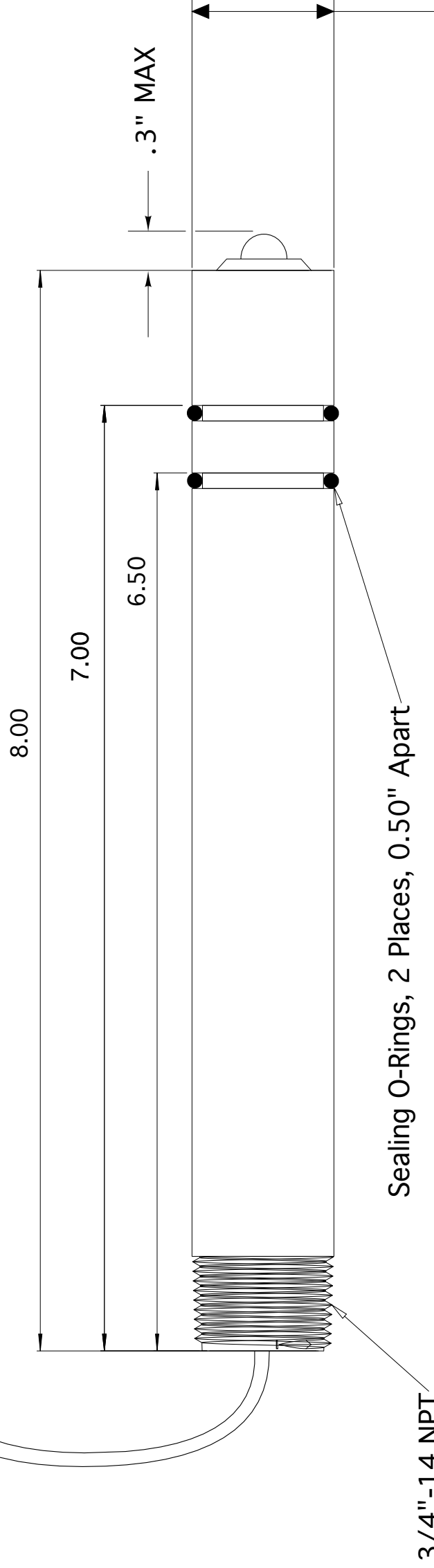

3/4"-14 NPT

Sealing O-Rings, 2 Places, 0.50" Apart

1:0.50

NOTES

1. All dimensions are in inches, unless otherwise indicated with tolerances as detailed below
2. Sensor body material of construction is RADEL (5X31), PEEK (5X41) or RYTON (5X51)
3. O-ring material of construction is Viton-75 standard; CV75, Simriz 485 & Kalrez 4079 Optional
4. Drawing as shown is without protective tines. The maximum displacement of the sensor past the end of the body in this configuration is 0.30" inches yielding a max overall length of 8.30 inches.
5. With Protective tines "GR" (4 places, 90 degrees apart) or "GRO" (2 places, 180 degrees apart) configurations overall sensor length is 8.00 inches.
6. This sensor is only for use with ASTI supplied sanitary and valve retractable sensor holders.
7. See installation procedures for proper insertion of this sensor into the mating holder.

B

B



Advanced Sensor Technologies U.S.A.
Website: <http://www.astisensor.com>

TOLERANCES		DRAWN BY RH
1 Place: ± .1	3 Places: ± .005	CHECKED BY TADP
2 Places: ± .01	4 Places: ± .0005	APPROVED BY MJP
Angular: ± 0.25°		

TITLE Sensor for Sanitary & HOT-TAP/Retractable Use			
SIZE B	PROJECT SAN / VR	DRAWING NO. 5-1 pH SENSORS	REV /
SCALE Not to Scale	MODEL 5X31, 5X41, 5X51	SHEET 1	OF 1

1

2

3

1

2

3

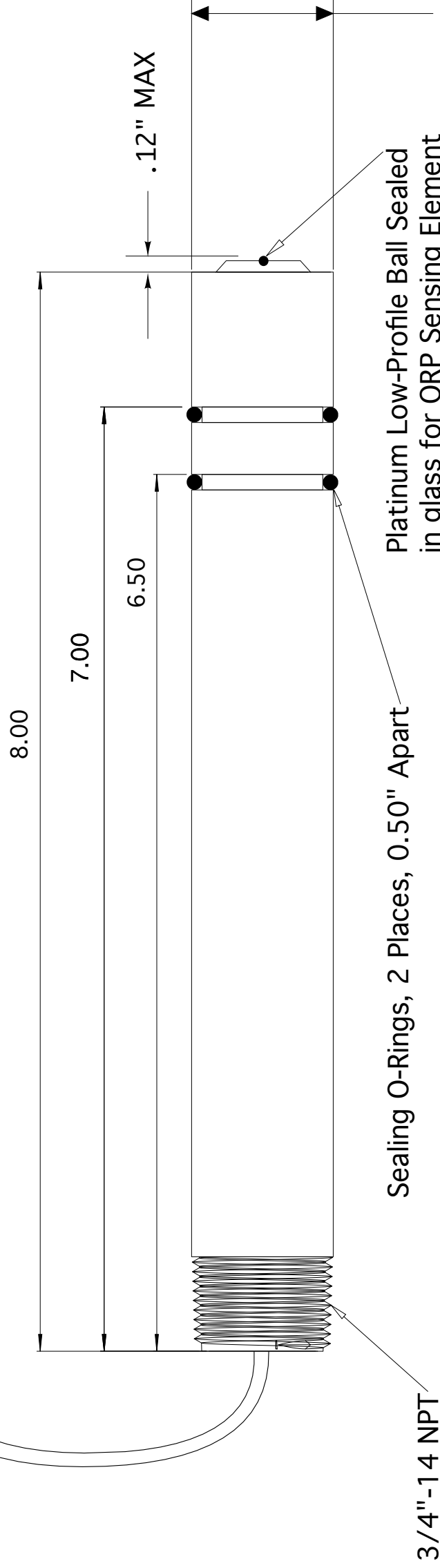
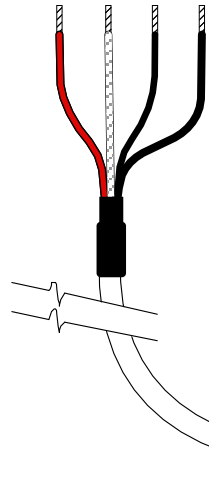

1.050

NOTES

1. All dimensions are in inches, unless otherwise indicated with tolerances as detailed below
2. Sensor body material of construction is RADEL (5X31), PEEK (5X41) or RYTON (5X51)
3. O-ring material of construction is Viton-75 standard; CV75, Simriz 485 & Kalrez 4079 Optional
4. Drawing shown without protective tines. Max protusion of low-profile platinum ball style X8XX series ORP sensor past body is 0.12" inches yielding a max overall length of 8.12 inches.
5. With Protective tines "GR" (4 places, 90 degrees apart) or "GRO" (2 places, 180 degrees apart) configurations overall sensor length is 8.00 inches.
6. This sensor is only for use with ASTI supplied sanitary and valve retractable sensor holders.
7. See installation procedures for proper insertion of this sensor into the mating holder.

B

B

REVISION HISTORY			
REV	DESCRIPTION	DATE	APPROVED



Advanced Sensor Technologies U.S.A.
 Website: <http://www.astisensor.com>

TITLE Sensor for Sanitary & HOT-TAP/Retractable Use			
SIZE B	PROJECT SAN / VR	DRAWING NO. 5-1-Pt Low-Profile ORP	REV /
SCALE Not to Scale	MODEL 5X31, 5X41, 5X51	SHEET 1	OF 1

1

2

3

1

2

3

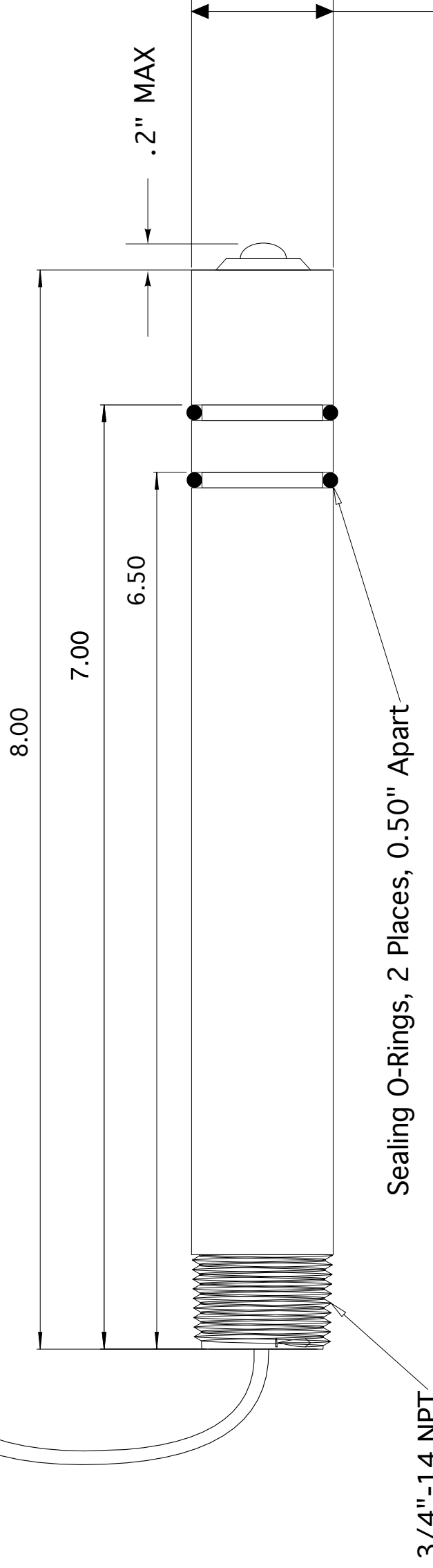
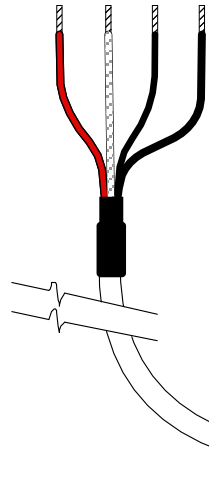

1.050

NOTES

1. All dimensions are in inches, unless otherwise indicated with tolerances as detailed below
2. Sensor body material of construction is RADEL (5X31), PEEK (5X41) or RYTON (5X51)
3. O-ring material of construction is Viton-75 standard; CV75, Simriz 485 & Kalrez 4079 Optional
4. Drawing shown without protective tines. Max protusion of low-profile parabolic slurry/viscous resistant X3XX series pH sensor past body is 0.20" inches yielding a max overall length of 8.20 inches.
5. With Protective tines "GR" (4 places, 90 degrees apart) or "GRO" (2 places, 180 degrees apart) configurations overall sensor length is 8.00 inches.
6. This sensor is only for use with ASTI supplied sanitary and valve retractable sensor holders.
7. See installation procedures for proper insertion of this sensor into the mating holder.

B

B



Advanced Sensor Technologies U.S.A.
 Website: <http://www.astisensor.com>

TITLE		Sensor for Sanitary & HOT-TAP/Retractable Use	
SIZE	PROJECT	DRAWING NO.	REV
B	SAN / VR	5-2 Low-Profile pH Glass	/
SCALE	MODEL	SHEET	OF
Not to Scale	5X31, 5X41, 5X51	1	1

1

2

3

Sanitary Sensor Options

- All 5X31, 5X41 & 5X51 series pH sensors and ORP sensors are supplied without tines (no guard) as the standard configuration (default). Four (4) each protective tines ("GR") or 2 each protective tines ("GRO") are available in both the full length 0.5" inches (for pH sensors) or the reduced 0.3" inch length (typically for parabolic pH or ORP sensors).
 - Contact the ASTI factory to decide which guard configuration is most appropriate for your planned installation.
- Fast temperature compensation response (Iotron™ AccuTemp™) option is recommend for all sanitary sensor installations.

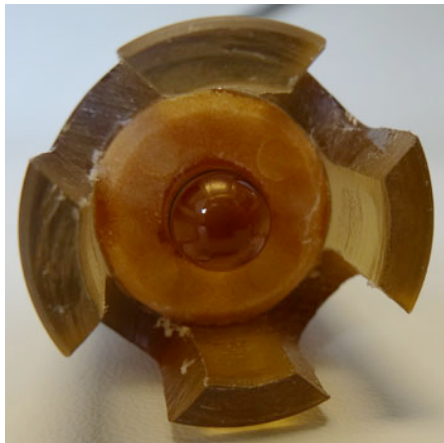

® Viton and Kalrez are registered trademarks of DuPont. Simriz is a registered trademark of Freudenberg Sealing Technologies (SIMRIT).

*** Additional charges apply for these options. Not all options available on all models (inquire to factory).**

APPENDIX "A"

Custom Applications

Dissolved Gas Resistant

Organic Media Applications*

Teflon Silicone Required*

Triple Junction*

High-Level HF Resistant*

Impact & break resistant low-profile parabolic pH glass for slurries*

Extreme Dehydration Resistant*

Custom Configurations

Accu-Temp Fast Temperature Response*

Low Impedance Glass*

316SS Solution Ground Addition*

Platinum Solution Ground Addition*

Platinum Solution Ground with 2 each half-cells for simultaneous use on two separate input channels or transmitters*

3-wire TC*

4 each Protective Tines*

2 each Protective Tines*

Shielded Preamplifier **Blue** Cable*

Upgrade from standard Viton® -75 to CV75, Simriz® 485 or Kalrez® 4079*

Add-On Alpha Prefix

“A” or “C”

“L”

“TS”

“TJ”

“HF”

“X3XX” & “X5XX” series

“E”

Add-On Alpha Prefix

“X”

“Z”

“Y”

“Pt”

“PtD”

“M”

“GR”

“GRO”

“BL”

“W”, “U” or “K” respectively