

ZEUS™ **SMART DIGITAL ORP SENSORS WITH ULTRA-RUGGED CONSTRUCTION FOR TOUGH PROCESS MEASUREMENT APPLICATIONS**

Description of Most Important
Common Core Features:

- Industrial ORP Sensors for Severe Service Inline, Immersion & Submersible Use**
- Waterproofing seal for complete cable isolation for submersion and field washdowns
 - Solid-state reference nearly impervious to ammonia, chlorine, sulfides & most solvents
 - ACCU-TEMP Fast Response Pt1000 Temperature Compensation "TC" element
 - Rugged thick 3.0mm (0.12") protective tines guard configuration, 4 each 90° apart
 - Thick 5.6mm (0.22") sensor body for 1.66" O.D. to endure tough mechanical wear
 - Standard 6 meters (20 feet) of integral cable with thick PVC jacket for aggressive use

Smart Digital Configuration of ZEUS™ ORP Sensors:

Short lead times for urgent commissioning of new systems or replacement of existing installs with very robust & advanced digital ORP measurement technology

FEATURES SPECIFIC TO SMART DIGITAL ZEUS™ CONFIGURATION

- * Integral smart digital board stores calibrations & transmitter configuration in sensor
- * Waterproof NEMA 6P quick disconnect HiQ4M Snap Corrosion Resistant Connector
- * Up to 610 meters (2,000 feet) noise insensitive digital cable with HiQ4F extensions
- * True plug and play sensor with automatic loading of calibration values for hot-swap
- * Calibrate conveniently in lab or shop and install quick-disconnect sensor in the field
- * Calibrate with sophisticated HiQ Windows software or any 3TX-HiQ-pH transmitter
- * Offset calibration yields relative mV ORP measurement for consistent control setpoints
- * Entire transmitter configuration can be downloaded to sensor or uploaded from sensor to intelligent 3TX-HiQ-pH transmitter for advanced management of field installations
- * Stores last five mV & temperature offset calibrations together with associated dates
- * See 3TX-HiQ documentation for complete set of smart digital features & functionality

Process Connections:

- 1" MNPT Threads on Front for Inline Screw-in Installations
- 1.25" MNPT Threads on Back for Immersion & Submersible Installations

General Sensor Specifications:

- Operating Temperature Range: -15 to +150°C for Inline/Immersion Use (Max +85°C for fully submersible installations)
- Operating Pressure Range: 1 to **200 psig** (6.9 to 1379 kPa)
- Sensor Body Material: RADEL® R-5000 NT (Poly-Phenyl-Sulfone, PPSU)
- Junction Support Matrix Material: KYNAR® (Poly-Vinylidene-Fluoride, PVDF)
- External Dimensional Drawing: See ZEUS™ Digital ORP Sensor 1"-1.25" MNPT Inline / Immersion / Submersible

ORP Measurement Specifications:

- Measurement mV Range: -1,000 to +1,000 mV absolute
- Measuring Glass Type: **Low Profile Platinum Ball Configuration;** For Slurries, High Pressure & Velocity
- ORP Glass Dimensions: 0.197" (5.0 mm) DIA

Reference System Specifications:

- Type: Triple Junction Standard
- Reference Half Cell: Ag/AgCl, Saturated KCl
- Triple Junction: - Solid-State Non-Porous Cross-Linked Polymer embedded in Kynar Support Matrix holds excess KCl assuring saturation at all temps for stability & long sensor service life
- Primary & Secondary Junctions: - Porous Ceramic, Saturated KCl in crosslinked polymer, Interfaced to Triple Junction

Some Selected Examples of Recommended Applications:

- Any process media where the redox (ORP) potential is monitored or controlled.
- Industrial & mining autoclaves, abrasive slurry & high viscosity solutions, sulfide service.
- Any measurement where aggressive chemical cleaning is needed to remove fouling or low-maintenance operation is required with minimal cleaning and re-calibration.
- Not for use in low conductivity, steam sterilization or steam type processes.**

Storage and Shelf Life:

- One (1) year from date of dispatch from ASTI factory when stored at indoor ambient room temperature with proper orientation & protector cap.

Platinum Low-Profile Ball Sealed into Glass ORP Sensing Element

Installation Approach # 3 Special for Smart Digital 3TX-HiQ Configuration

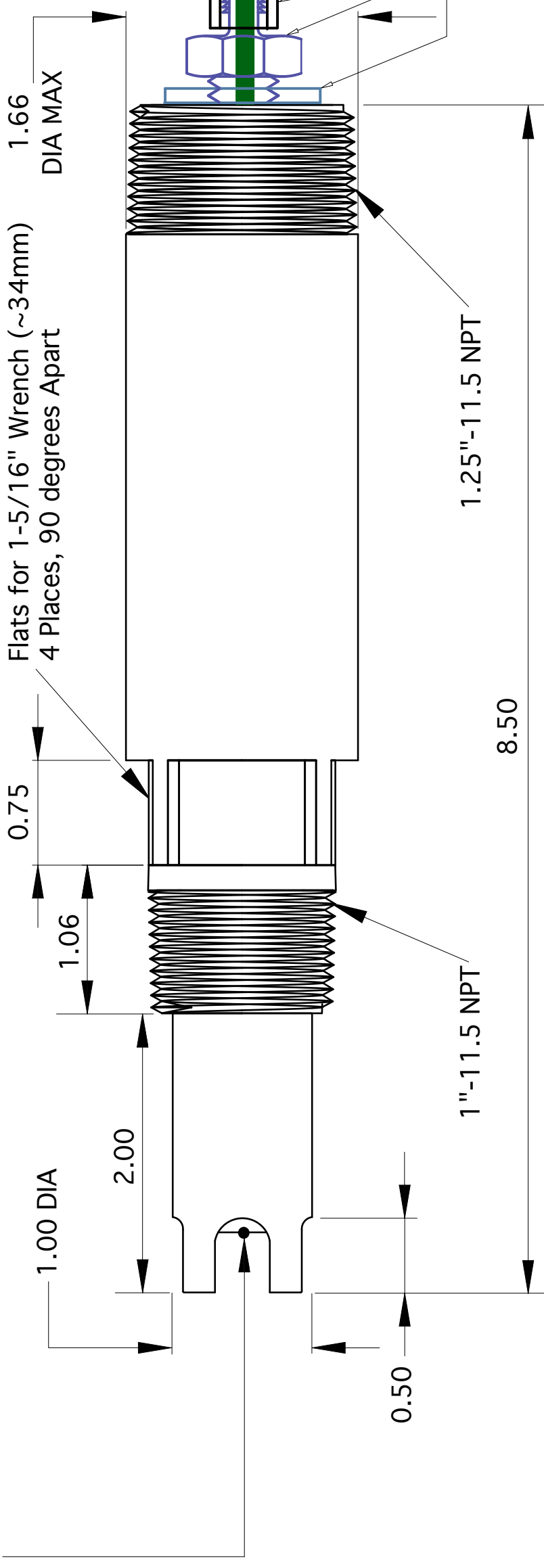
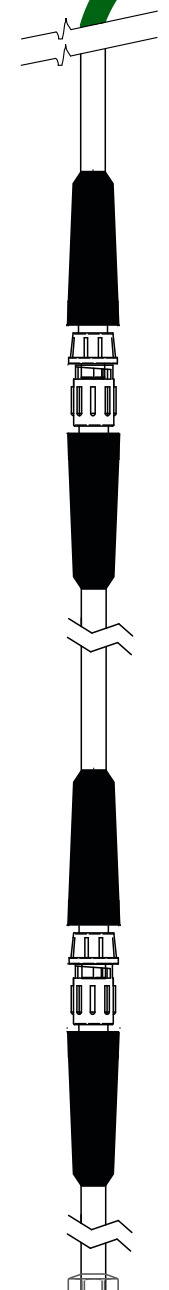
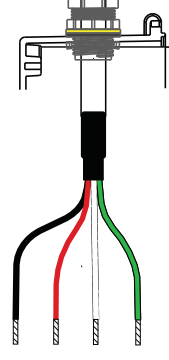

0.75
1.06
1.66 DIA MAX
1.25"-11.5 NPT
8.50
1"-11.5 NPT

Flats for 1-5/16" Wrench (~34mm) 4 Places, 90 degrees Apart

A

A

NOTES

1. All dimensions are in inches with tolerances as detailed below
2. Sensor body material of construction is RADEL R-5000 NT
3. Support matrix for solid-state cross-linked conductive polymer reference system is KYNAR (PVDF) material of construction
4. Protective tines 4 places, 90 degrees apart, 0.12 inches (3.0mm) thick
5. Smart digital 3TX-HiQ-pH configuration uses HiQ4M quick disconnect snap connector with 20 feet cable. Use HiQ4F snap cable extensions to achieve desired total cable length for field install.
7. See hook-up schematic to interface tinned leads to mating 3TX-HiQ-pH intelligent pH transmitter.
8. Do not use any sensor beyond the factory defined maximum temperature or pressure rating.

Installation Approach # 1 for Smart Digital 3TX-HiQ Configuration

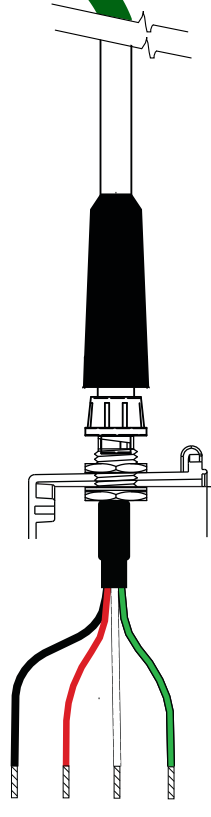

B

B



Advanced Sensor Technologies U.S.A.
Website: <http://www.astisensor.com>

DRAWN BY TADP		CHECKED BY TADP		APPROVED BY MJP	
TOLERANCES		1 Place: ± .1		3 Places: ± .005	
		2 Places: ± .01		4 Places: ± .0005	
		Angular: ± 0.25°			
TITLE 1"-1.25" MNPT Inline / Immersion / Submersible					
SIZE B	PROJECT ULTRA RUGGED	DRAWING NO. ZEUS™	Digital ORP Sensor /		
SCALE Not to Scale	MODEL Smart Digital 3TX-HiQ-pH	SHEET 1	OF 1		

3TX-HiQ Intelligent Transmitters for Smart Digital Sensors Measurement Platform Recommended Field Installation Guide

Tinned leads connected to the 3TX-HiQ can be from:

- “A” - leads from panel mount connector installed into transmitter enclosure (done at ASTI factory) *or*
- “B” - female snap to tinned lead cable extensions with sealing glands installed into transmitter enclosure (done either at install site or time of commissioning).
- In “A” or “B” installation approach above the wiring to transmitter need be done only once. Subsequent sensor exchanges in field for cleaning, recalibration or replacement do not require interfacing with the input terminals on the transmitter board in any manner.

Wiring of Tinned Leads to 3TX-HiQ Transmitter

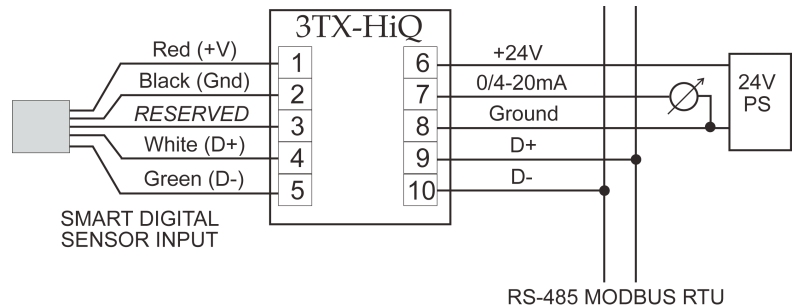

FIELD INSTALLATION SCHEMES - PART 1

Please review the first two pages of the 3TX FAQ before wiring-up or powering on any of the 3TX modules.

Installation approaches for genuine Smart Digital Iotron™ pH & ORP type HiQ sensors are detailed in the following pages.

BASE HiQ pH & ORP SENSOR CONFIGURATION:

All smart digital Iotron™ pH and ORP HiQ style sensors for use with 3TX-HiQ-pH transmitters come standard with 6 meters (20 feet) of integral cable and include quick disconnect male terminated IP67 & NEMA 6P rugged field ready connector. Shorter cable lengths of 1.5 meters (5 feet) and 3 meters (10 feet) are also available but there is no difference in cost for these shorter sensor cable lengths.

Installation requiring cable runs longer than 6 meters (20 feet) can be achieved using the approach #2 & #3 options for field installation detailed below. Best practice is to use the well stocked standard sensor cable lengths and cable extension options for the lowest cost and best availability of your 3TX-HiQ-pH installation. Longer cable lengths can also be achieved by use of the **special order options indicated in green** in PART 2 of this guide but this approach may lead to longer lead times for fabrication.

Approach # 1

Directly connect male snap termination of smart sensor to female panel mount installed on 3TX-HiQ transmitter enclosure
→ Length of cable ordered for sensor must be sufficient to interface to enclosure for this approach. Standard 6 meter length (20 feet) with optional shorter 3 meters (10 feet), 1.5 meters (5 foot) lengths also available for the exact same HiQ option adder cost.

Approach # 2

Use snap to snap cable extensions terminating into female panel mount plug installed on 3TX-HiQ transmitter enclosure
→ Length of cable between sensor and snap to snap cable extension(s) must be sufficient to interface to enclosure for this approach. The use of multiple snap to snap cable extensions is ASTI factory supported and will not result in signal degradation so long as the maximum 610 meters (2,000 feet) of total cable length is not exceeded.

Approach # 3

Use female snap to tinned leads cable extensions with sealing cable glands installed into enclosure for 3TX-HiQ transmitter
→ Female snap to tinned lead cable extensions can be mated with the sensor male snap connector or else to a snap to snap cable extension. If the female snap to tinned leads cable extensions is employed, it should always be used as the final portion of the installation so that this cable interface the 3TX-HiQ transmitter input terminal board (see wiring schematic option “B” above).

GENERAL NOTE:

The sensor terminations are always male snap connector. The female snap to male snap cable extensions and female snap to tinned leads cable extensions can be used in any combination without signal degradation so long as the maximum supported 610 meters (2,000 feet) of total cable length is not exceeded.



FIELD INSTALLATION SCHEMES – PART 2

Find detailed below the standard and special order cable length installation options using the HiQ smart digital platform.

Integral Cable Length Options for HiQ Sensors

- All HiQ style sensors come standard with male snap connector. Standard integral cable length is 6 meters (20 feet).
- Shorter 3 meters (10 feet) or 1.5 meters (5 feet) integral sensor cable lengths also terminating with male snap connector available for same price as standard 6 meter (20 foot) length. Specify shorter lengths by -HiQ-1.5m or -HiQ-3.0m coding. If standard -HiQ option is invoked the sensor is supplied with standard 6 meters (20 feet) of cable & male snap connector.
- **12 meters (40 feet) of integral sensor cable with male snap connector available as a *special order option (-HiQ-12m)*.**

Female Snap to Male Snap Cable Extension Options

- 3 meters (10 feet) HiQ4F-3m-HiQ4M
- 6 meters (20 feet) HiQ4F-6m-HiQ4M
- 12 meters (40 feet) HiQ4F-12m-HiQ4M
- 24 meters (80 feet) HiQ4F-24m-HiQ4M – Special Order Option Only**

Female Snap to Tinned Leads Cable Extension Options

- 1.5 meters (5 feet) HiQ4F-1.5m-TL
- 3 meters (10 feet) HiQ4F-3m-TL
- 6 meters (20 feet) HiQ4F-6m-TL
- 12 meters (40 feet) HiQ4F-12m-TL – Special Order Option Only**

POSSIBLE TOTAL CABLE LENGTH INSTALLATIONS USING APPROACH #1, #2 or #3

Approach # 1: Sensor with integral cable only with male snap connected directly to female panel mount:
STANDARD is 6m (20ft) with shorter 1.5 meters (5 feet), 3 meters (10 feet) cable lengths also available for same price
→ **12m (40ft) integral cable length terminating with male snap connector also available as Special Order Option**

Approach # 2: Sensor with integral cable and female to male snap cable extension connected to female panel mount:

	<u>+3 meters</u>	<u>+6 meters</u>	<u>+12 meters</u>	<u>+24 meters</u>
With 1.5m (5ft) integral sensor cable:	4.5m (15 feet)	7.5m (15 feet)	13.5m (45 feet)	25.5m (85 feet)
With 3m (10 ft) integral sensor cable:	6.0m (20 feet)	9.0m (30 feet)	15m (50 feet)	27.0m (90 feet)
With 6m (20 ft) integral sensor cable:	9.0m (30 feet)	12m (40 feet)	18m (60 feet)	30.0m (100 feet)
With 12m (40 ft) integral sensor cable:	15m (50 feet)	18m (60 feet)	24m (80 feet)	36.0m (120 feet)

Approach # 3: Sensors with integral cable and female snap to tinned leads cable extension to 3TX-HiQ input terminals:

	<u>+1.5 meters</u>	<u>+3 meters</u>	<u>+6 meters</u>	<u>+12 meters</u>
With 1.5m (5ft) integral sensor cable:	3m (10 feet)	4.5m (15 feet)	7.5m (15 feet)	13.5m (45 feet)
With 3m (10 ft) integral sensor cable:	4.5m (15 feet)	6m (20 feet)	9m (30 feet)	15m (50 feet)
With 6m (20 ft) integral sensor cable:	7.5m (15 feet)	9m (30 feet)	12m (40 feet)	18m (60 feet)
With 12m (40 ft) integral sensor cable:	9m (30 feet)	12m (40 feet)	18m (60 feet)	24m (80 feet)

Standard installations requiring cable lengths longer than 18 meters (60 feet) or *special order style installations requiring cable lengths longer than 36 meters (120 feet)* are achieved by using multiple female snap to male snap cable extensions. This can increase the total cable length in increments of 3m (10 feet), 6m (20 feet) & 12m (40 feet) or **24m (80 feet) with special order snap to snap cable extensions**. The snap to snap & snap to tinned leads cable extensions can be used together in any combination without signal degradation provided the *maximum supported 610 meters (2,000 feet) total cable length is not exceeded*.

Items denoted in GREEN are special orders. This means that there may be limited availability and/or extended lead times for purchase of these items or to invoke these options. Contact ASTI factory or distributor for further details.

FIELD INSTALLATION SCHEMES - PART 3

Detail drawing for standard smart digital HiQ sensor male snap connector cable termination (-HiQ-Xm):

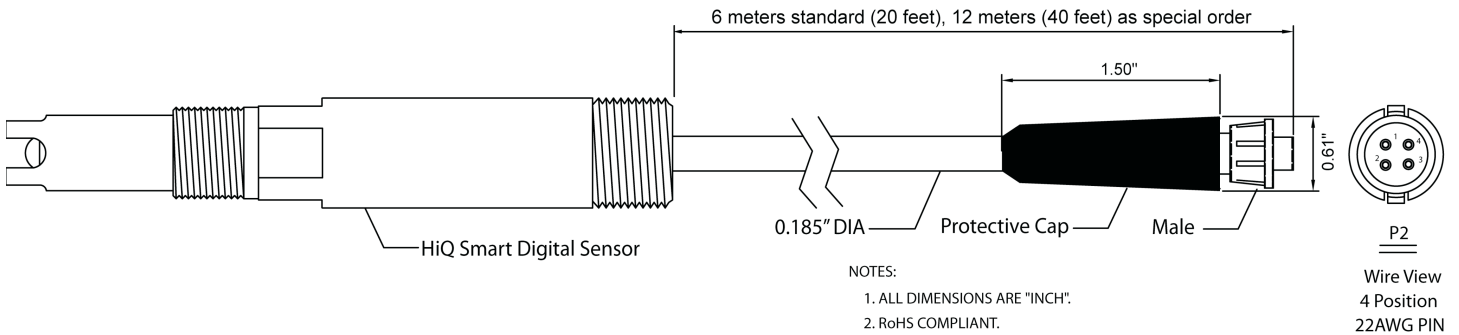

Detail drawing for female snap to male snap HiQ4F-Xm-HiQ4M cable extensions:

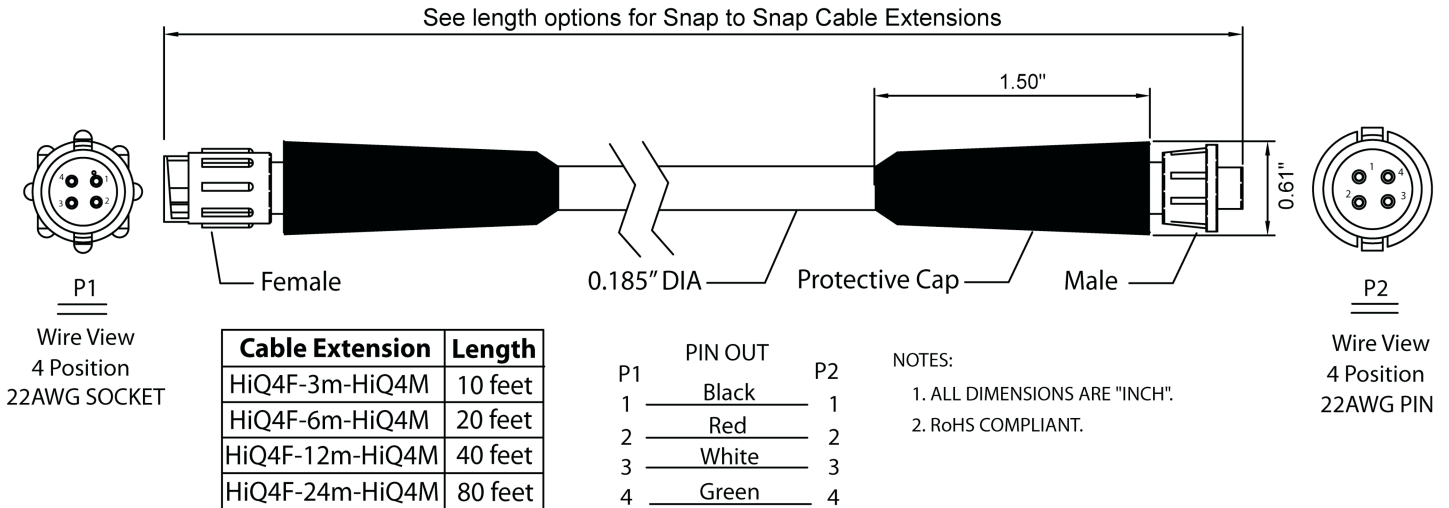

Detail drawing for female snap to tinned leads HiQ4F-Xm-TL cable extensions:

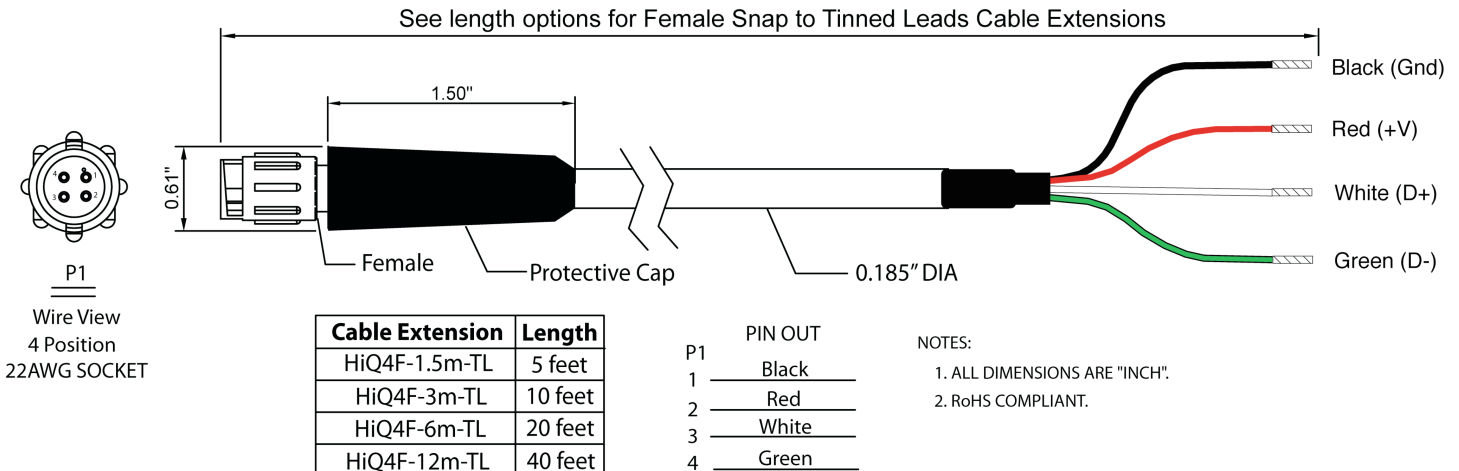

FIELD INSTALLATION SCHEMES - PART 4

The terminal assignments for red, black, white & green colored leads are detailed on page 1 of this installation guide. Care should be taken when making these connections to follow the terminal assignments exactly to avoid damaging the HiQ sensor or transmitter. No connection of any kind should be made to the factory-reserved input terminal 3.

Assembly Drawing for Installation Approach # 1:

Smart digital HiQ sensor with male snap connector is interfaced directly to female panel mount snap connector that has been installed into enclosure assembly. This approach requires the max distance between sensor & transmitter is no more than 6 meters (20 feet) for the standard digital HiQ sensors or 12 meters (40 feet) for the special order long cable version.

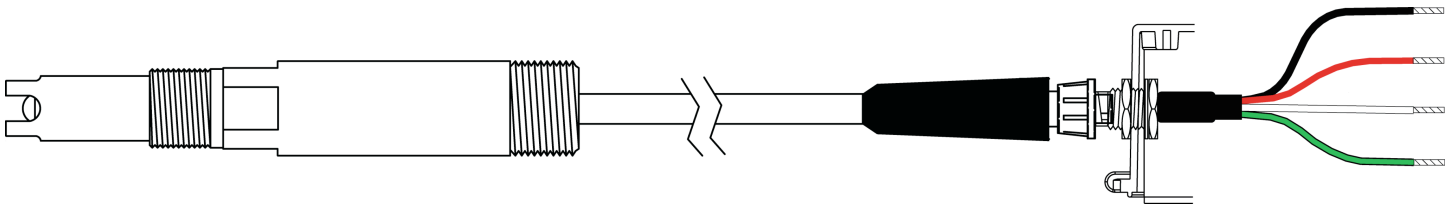

Assembly Drawing for Installation Approach # 2:

Smart digital HiQ sensor terminated with male snap connector is bridged with snap to snap (HiQ4F-Xm-HiQ4M) cable extension which is interfaced to female panel mount snap connector that has been installed into enclosure assembly. Multiple snap-to-snap extension cables can be employed as desired at time of commissioning or any time thereafter.

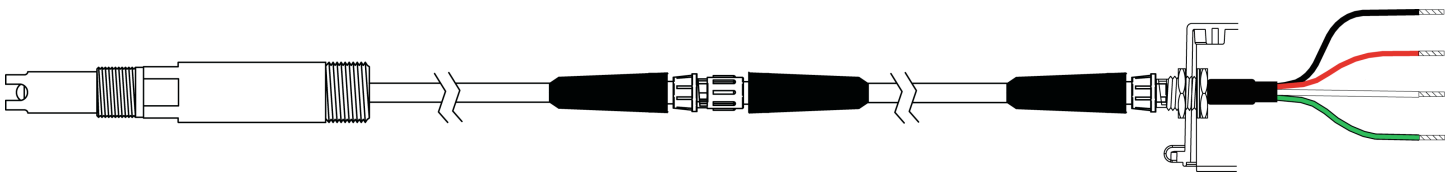

Assembly Drawing for Installation Approach # 3:

Smart digital HiQ sensor terminated with male snap connector is bridged with snap to tinned leads (HiQ4F-Xm-TL) cable extension. The tinned leads are interfaced to 3TX-HiQ terminals & sealing cable gland is installed in enclosure assembly to secure the cable. This approach is typically used for retrofit installation where a cable gland has already been installed.

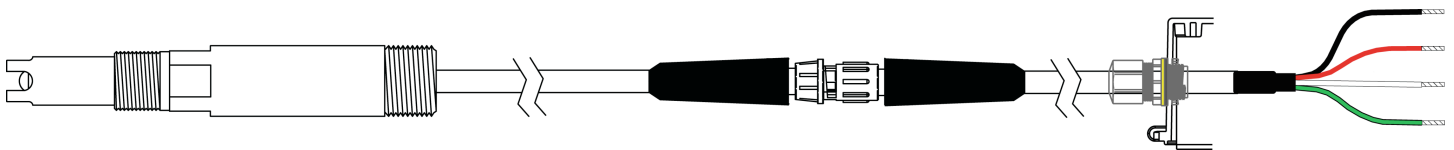

Assembly Drawing for Installation Approach # 3 (Special)

Smart digital HiQ sensor terminated with male snap connector is bridged with both snap to snap (HiQ4F-Xm-HiQ4M) cable extension and snap to tinned leads (HiQ4F-Xm-TL) cable extensions. The tinned leads are ultimately interfaced to 3TX-HiQ terminals and sealing cable gland is installed in enclosure assembly. See page 1 for terminal assignments.

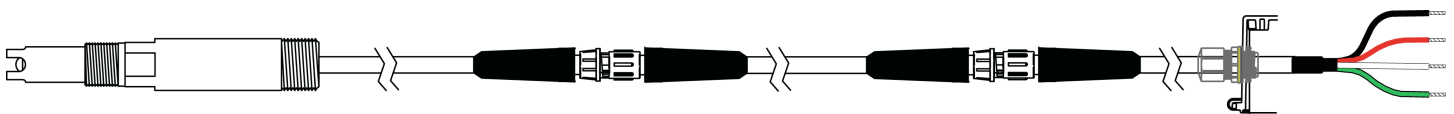

3TX-HiQ Digital Measurement System Troubleshooting Guide & FAQ

!!! WARNING !!!

The 3TX-HiQ digital transmitters are ONLY for use with genuine ASTI supplied IOTRON™ smart digital HiQ sensors. Connecting any other sensor (analog or digital) may permanently damage the 3TX-HiQ transmitter and/or improper sensor. If there should be any doubt as to whether you are connecting a genuine ASTI supplied IOTRON™ HiQ digital sensor to the 3TX-HiQ digital transmitter, please inquire to the ASTI factory for verification.

The smart digital HiQ sensors are designed for a seamless and simple plug and play type operation with the intelligent digital 3TX-HiQ transmitters. In the case that any exception occurs a variety of diagnostic information may be displayed in the form of error codes reported on the 3TX-HiQ LED display. Instructions about what should be done if any of these error codes or diagnostic messages are displayed is provided below to assist with troubleshooting initial commissioning as well as ongoing maintenance of your installation.

The troubleshooting steps below are meant for use together with the specific 3TX-HiQ transmitter documentation in question as well as the general shared 3TX FAQ documentation rather than just as a standalone guide. Error codes are shown flashing on the display in the format "X.Y" where "X" is from 1 to 10 and "Y" can vary from 0 to 9. The exact coding designations are generally only relevant for internal uses by the ASTI factory. In particular the "Y" portion of the error code can be safely ignored unless specifically requested for remote diagnostic troubleshooting assistance purposes.

NO SENSOR CONNECTED OR IMPROPER WIRING ERRORS

If no genuine IOTRON™ smart digital HiQ digital sensor is connected, it is expected that one or more error will be reported including the 2.Y type error code. If there is an HiQ digital sensor connected but it is not interfaced to the correct type of mating HiQ transmitter you will get a 3.Y measurement type mismatch error. It is very important to make sure that the four leads from the smart digital HiQ sensor are properly wired to the terminals on the 3TX-HiQ transmitter to prevent damage to the electronics. Please see page one (1) for the color coding and terminal designations of the four leads. Since the HiQ digital measurement system employs a NEMA 6P rated quick disconnect termination, the tinned lead connections need only be made correctly once to the HiQ transmitter.

COMMUNICATION ERRORS

If an HiQ digital sensor is properly connected and an error code of the type 1.Y, 4.Y, 5.Y, 6.Y, 9.Y or 10.Y is received then these indicate that some form of a communication exception has occurred. Such errors are quite rare. If observed at all they are typically quite brief in duration signifying a very brief transient temporary communication issue. If these error codes starting with 1, 4, 5, 6 or 9 persist this indicates that there was some damage to the electronics inside the HiQ digital sensor and it must be replaced. Typically some ground loop or electrical/installation issue is responsible for this damage.

DATE STAMPING ERRORS

If an error code of the type 7.Y or 8.Y is received then these indicate that some form of an error has occurred related to setting the field activation or the last date of field use. These errors are also extraordinarily rare and indicate either an improper configuration or else a corruption to that portion of the EEPROM (very unlikely). If the issue is simply an improper configuration this can be resolved at the ASTI factory. The sensor item number, serial number, invoice number and dispatch date will be requested for approval of any such return. All of this information can be obtained from the HiQ transmitter to which the digital sensor is connected by looking at the appropriate parameters (see transmitter manual).

GENERAL TROUBLESHOOTING TIPS

- Ensure that all snap connections with the extension cables are secure and that none of the pins are damaged.
- Ensure that there is good integrity of PVC insulation on leads & cable jacket for both sensor and/or extension cables.
- Disconnect and reconnect the digital sensor via the snap connection. Allow ~5 to 10 seconds before reconnecting.
- Cycle the power to the transmitter and swap out the extension cable for a unit that is known to be working.
- Connect a genuine HiQ digital sensor known to be working to ensure 3TX-HiQ transmitter is functioning normally.



THIS PAGE HAS BEEN INTENTIONALLY LEFT BLANK

CALIBRATION INSTRUCTIONS FOR SMART DIGITAL ORP SENSORS WITH INTELLIGENT 3TX-HiQ-pH TRANSMITTERS

If softwarelock (P01) is "On" then no changes can be made. Set P01 to "Off" to allow calibrations & configuration modifications. The P01 software lock will automatically reset back to "On" if no key is pressed for 60 seconds.

ORP CALIBRATION INSTRUCTIONS

The ORP sensors can only undergo an 'Offset' type calibration performed in manual mode. Automatic calibration mode is disabled for ORP sensors. Toggle to 'Offset' LED mode with 'Mode' and use the 'Up' and 'Down' buttons to adjust mV reading to match desired value of ORP standard solutions or else to agree with an offline determined ORP reference value of the inline process media. Negative values will be shown as flashing. The live working mV offset calibration for ORP sensor can be viewed and adjusted in P16. *

Calibrate ORP mode has a 2 second averaging for & 10 second averaging for the ORP measure mode.

TEMPERATURE CALIBRATION INSTRUCTIONS

Temperature calibrated by pushing the 'Up' or 'Down' buttons when in the temperature display (°C) mode. *

HISTORICAL CALIBRATION VALUES (DISPLAY / READ ONLY PARAMETERS)

- The working mV offset * (P16) can be viewed whether you perform automatic or manual calibrations. **If P01 lock is 'Off', the live P16 values can be manually adjusted (only recommend for experienced users).**
- The historical calibration values can only be downloaded to file via the free ASTI HiQ Windows software
- Use P34 define calibration number shown for mV offset (P35) and temp (P38)
- The historical mV offset * calibrations shown with P35 (Valid for pH sensors & ORP sensors)
- The historical temperature offset calibrations shown with P38 (Valid for all measurement and modes)
- The date associated with each calibration can be viewed as a display feature (see **** explanation below)

DISPLAY FEATURES IN MAIN pH/MV LED MODE:

- The absolute mV value * of sensor is displayed with 'Down' key in pH/mV LED mode.
- The current mA output selected scaling displayed by pressing the 'Up' key in pH/mV LED display mode.
- The production date formatted as (yy.m) is displayed by pressing 'Down' & 'Mode' key simultaneously
- The software revision number is displayed by pressing 'Up' & 'Mode' key simultaneously

DISPLAY FEATURES REQUIRING 3TX-HiQ TO HAVE P01 SOFTWARE LOCK 'ON' TO BE ENABLED

- If 'Down' is pushed in °C LED mode offset in °C units * for current temperature offset calibration is shown.
- If 'Down' is pushed in 'Offset' LED mode, the current offset calibration in units of mV * (P16) is shown

* Negative values shown as flashing.

**** Calibration reference number (P34) associated with P35-P38 calibrations is accessed by pushing 'Down' button while value is shown. Date associated with calibration is accessed by pushing 'Up' button while value is shown: Date format is "H"+ last two digits of year, then "m.dd" where "m" is month shown as 1-9 for Jan-Sept & A=Oct, b=Nov, C=Dec & "dd" is day of month (October 8th 2015 shown as "H15" followed by "b.08")

Last Modified May 23, 2016 | Revision 8



CLEANING, CARE & MAINTENANCE RECOMMENDATIONS FOR ZEUS™ pH SENSORS

Note: The recommendations given in this document are valid the ZEUS™ Industrial pH sensors. Best practice care and maintenance for your particular installation may vary from that described here. Contact the factory for specific information regarding proper care and maintenance of your given installation scheme and process application conditions.

Storage

The standard shelf life for all Iotron™ pH and ORP sensors is one year from the date of shipment. Sensors stored longer than this period may still be functional but are no longer under warranty. Sensors should be stored in a cool, dry location with the sensor tip (where the pH/ORP element is located) oriented toward the ground. All sensors come standard with a conditioning solution in the cap. This conditioning solution is 50% pH 4 buffer and 50% saturated potassium chloride (mixed by volume). The sensor cap should be kept tightly affixed to the sensor body and sealed with common piping teflon tape when the sensor is not in use. Sensors that are to be returned for shelf life warranty claim must have the original sensor cap and conditioning solution intact to be eligible for warranty replacement. Contact the ASTI factory before returning any sensor for warranty claim to obtain a valid RMA.

Cleaning

Cleaning methods can vary greatly depending upon the application for which the sensor is used. Some common rules for cleaning include:

- 1) Never scratch or aggressively scrub the pH or ORP elements. These are delicate glass electrochemical electrodes. They can be broken easily by mechanical force.
- 2) The reference junction is a solid state non-porous cross-linked conductive polymer embedded in a porous kynar matrix. Since the reference is solid state, it can be cleaned with aggressive chemicals. This solid state reference can also be cleaned effectively by using a sharp razor edged tool. GREAT CARE SHOULD BE TAKEN NOT TO SCRATCH THE pH GLASS OR ORP ELEMENT DURING CLEANING OF THE REFERENCE JUNCTION.

Common approved cleaning solutions include:

5-15% Hydrochloric Acid – (For Alkaline deposits)
5-15% Sodium Hydroxide – (For Organic Contaminants)
Surfactant (NON-IONIC SOAPS SUCH AS MICRO-90)

Please inquire to the factory if you plan to use any other cleaning agent.

Conditioning for Calibration

After the sensor has been cleaned, it must be thoroughly rinsed with deionized water to remove any residual cleaning reagents. The sensor can then be soaked in pH 4 buffer to recondition the pH and reference elements. Some sensors will also require a conditioning in saturated potassium chloride if the reference junction has been depleted of the ions in the solid state conductive polymer (typical for clean water applications). Condition the sensor in saturated potassium chloride and/or pH 4 buffer for whatever period of time is required to achieve optimal calibration results.

Sensor Selection for Individual Process Lines

No sensor should be used beyond the indicated temperature and pressure limitations for that given sensor. Sensors should only be used for the application(s) that an authorized ASTI representative has recommended. If you are unsure that your sensor is recommended for a particular application, please contact the factory.

If you should have any doubt about whether the exact sensor model that you are using is appropriate for the installation style that you are planning to implement, please contact the factory for further assistance!