

# Installation Guide & User Manual

## Six (6) Channel Touchscreen Controller for Smart Digital HiQDT pH, ORP, Dissolved Oxygen, Ion Selective & Conductivity Sensors

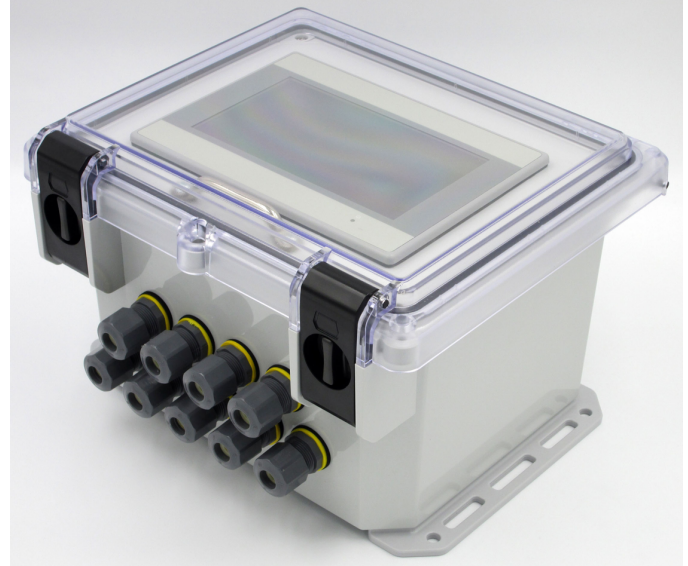

Six (6) channel controller with 7.0" touchscreen shown on left with bottom input ports & top output ports shown on right. Six (6) HiQ4FP panel connectors are waterproof input ports for sensors. Integral 1/2"NPT cable glands number five (5) on bottom input side & nine (9) on output side for NEMA 4X wiring of power, analog & digital outputs, contact relays & remote access via ethernet port.

### INSTALLATION & USER GUIDE VERSION 9.2 - Build Date October 2, 2021

This controller offers turn-key plug & play solution to perform pH, ORP, dissolved oxygen (D.O), ion selective (ISE) and conductivity (EC) field measurements taking advantage of all features of the smart digital HiQDT MODBUS RTU sensors. The custom coded software allows for seamless integration on proven industrial HMI & PLC equipment from Maple Systems with CE, CSA & UL approvals. Configurations are available for use in hazardous Class I, Division II rated areas as well as lower cost configuration suitable for use in non-hazardous safe areas. For general documentation aspects of the Maple System HMI & PLC hardware refer back to the Maple Systems documentation provided on the following page.

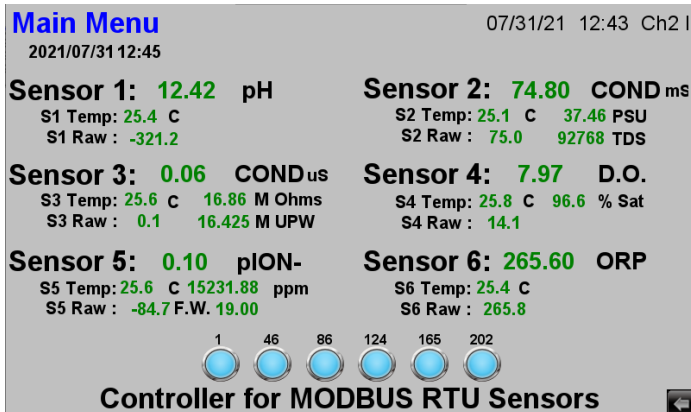

Default main display window for the six channel configuration. Access to all other screens is obtained through the main menu. Status updates, alarms & alerts are scrolled across top of screen.

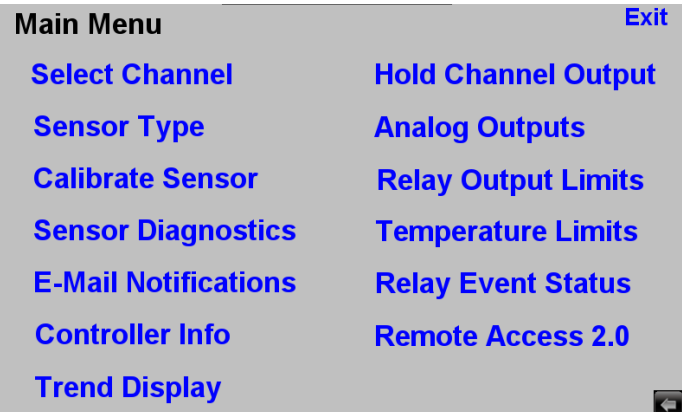

The main menu that highlights the major various tasks and functionality of the controller. Addition submenus will load as appropriate to further navigate the available features & options.

## HARDWARE FOR SIX CHANNEL ADVANCED TOUCHSCREEN CONTROLLER:

- Serpac I352HL,TCBG NEMA 4X Enclosure with Clear Hinged Latched Door ready for wall or pipe mounting
- Serpac 7200HP Plastic Swivel Top Plate with Cutout for HMI5070 advanced touchscreen with pull handle
- Serpac 7200B Aluminum Bottom Plate for mounting of 35mm DIN-RAIL assemblies
- 5 each input side and 9 each output side ½" NPT cable glands factory installed into NEMA 4X enclosure assembly

Maple Systems Model HMI5070L or HMI5071L 7.0" Advanced Touchscreen HMI (Max 300mA / 450mA @ 24VDC)

<https://www.maplesystems.com/product/modelname/hmi5070l>

<https://www.maplesystems.com/product/modelname/hmi5071l>

Maple Systems Model MLC1-E0808Y0402T PLC (Max 500mA @ 24VDC)

<https://www.maplesystems.com/product/modelname/mlc1-e0808y0402t>

Maple Systems Model MLE-A0004 - I/O Expansion Module | 4 Analog Outputs (Max 80mA @ 24VDC)

<https://www.maplesystems.com/product/modelname/mle-a0004>

Maple Systems Model MLE-D0016R - I/O Expansion Module | 16 each Relays (Max 200mA @ 24VDC)

<https://www.maplesystems.com/product/modelname/mle-d0016r>

- 1 each CUI PQDE6W-Q24-S12-DIN or PYBE30-Q24-S12-DIN 9-36 to 12 VDC Converter/Isolator for HiQDT Sensors
- 6 each isolated analog outputs (scalable and selectable as 4-20mA or 0-10VDC)
- 22 each isolated contact relays Max 2A at 230VAC or 30VDC (12 ea separate process Hi/Lo & 6 ea shared for Hi/Lo)
- 6 each HiQDT discrete sensor inputs (Prewired to HMI Isolated Serial Input Port)
- MODBUS MODBUS TCP Slave (a.k.a. MODBUS over Ethernet)

ASSEMBLY SIZE: 11.8 inches (300mm) Width X 11.0 inches (280mm) Height X 7.5 Inches (190mm) Depth

NET WEIGHT: 9.2 Pounds (4.2 kilograms)

SHIPPING BOX: 14 inches X 12 inches X 9 inches

SHIP WEIGHT: 10.2 pounds (4.6 kilograms)

### POWER CONFIGURATIONS:

**HiQDT-CTRL-6CH(S)-PS0** No Integral Power Supply; Customer to supply suitable isolated & regulated 24VDC Power  
**HiQDT-CTRL-6CH(S)-PS1** 85 to 264 VAC Power Operation with Mean Well 4010-0010 24VDC Max 1.7A (2.5A Optional)  
**HiQDT-CTRL-6CH-PS1C1D2** 85 to 264 VAC **Class 1 Div 2** Power Operation with RHINO PSB24-060S(-P) Max 2.5A  
**HiQDT-CTRL-6CH(S)-PS2** 18 to 75 VDC with RHINO DC/DC PSP24-DC24-2 Max 2.5A  
**HiQDT-CTRL-6CH(S)-PS4** 9 to 36 VDC 2 ea PYBE30-Q24-S24-DIN (2.5A Max) or 1 ea PQAE50-D24-S24-DIN (2.08A Max)

**SUPPORTED AMBIENT OPERATING TEMPERATURES FOR ALL CONFIGURATIONS ARE 0 to 50° C**

### SOFTWARE:

Advanced menu-driven touchscreen interface for all features and functionality as detailed in this manual.

### INDIVIDUAL COMPONENT MAX POWER CONSUMPTION @ 24VDC:

HMI5070L @ 300mA

HMI5071L @ 450mA

MLC1-E0808Y0402T @ 500mA

MLE-A0004 Module @ 80mA

MLE-D0016R Module @ 200mA

6 each HiQDT Sensors: All pH/ORP/ISE/DO 90mA Max or All Conductivity 210mA Max (Typical Current Draws)

### MAX TOTAL POWER CONSUMPTION @ 24VDC FOR VARIOUS CONTROLLER CONFIGURATIONS

HiQDT-CTRL-6CH-PSX with HMI5070L using 6 each pH/ORP/ISE/DO Sensors: 1,170mA

HiQDT-CTRL-6CH-PSX with HMI5070L using 6 each Conductivity Sensors: 1,290mA

HiQDT-CTRL-6CHS-PSX with HMI5071L using 6 each pH/ORP/ISE/DO Sensors: 1,320mA

HiQDT-CTRL-6CHS-PSX with HMI5071L using 6 each Conductivity Sensors: 1,440mA

## PHOTOS OF 3 & 6 CHANNEL ADVANCED TOUCHSCREEN CONTROLLER

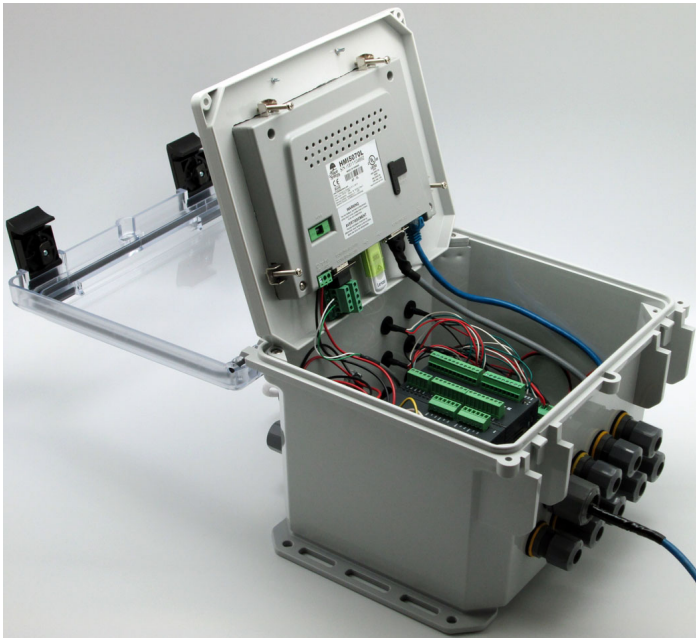

*HiQDT-CTRL-6CH six (6) channel controller with 7.0" touchscreen HMI is shown with lid & swivel plate open. The HMI & PLC are interfaced with only the power terminal block and communication cable cable allowing for simple and convenient replacement if damaged. Clear hinged latched door provides NEMA 4X protection for advanced touchscreen HMI from environment. To access internal components of controller simply remove two top screws & open with pull handle.*



*The rear mounting plates on back of the controller as supplied make it ready for immediate wall or pipe mounting in the field without the purchase of any additional specialized hardware. Standard commercial U-Bolt can be used for achieve a pipe mounting scheme & commercial bolts and washers can be used to achieve mounting to a wall or plate. Inquire for any planned installation schemes that are not covered by the brackets shown above which are suitable for most all of the typical wall or pipe mounting schemes.*

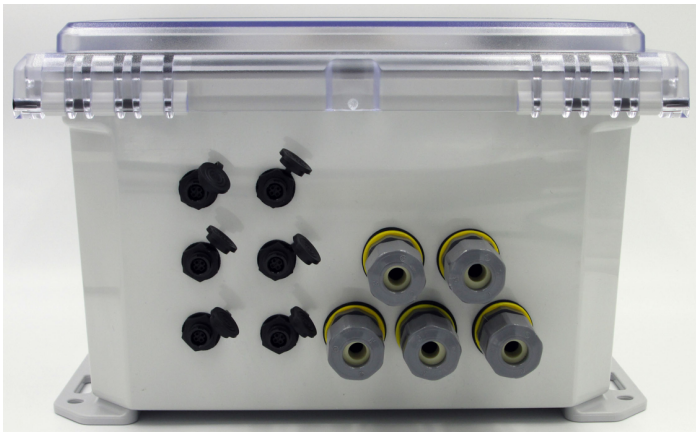

*On bottom input side are factory installed 5 each 1/2" NPT cable glands and 6 each NEMA 6P rated female snap panel mount connectors for plug & play hot-swappable HiQDT smart digital sensors. Sealing cap for panel connectors should be secured and provided caps for cable glands affixed when not in use to maintain NEMA 4X rating.*

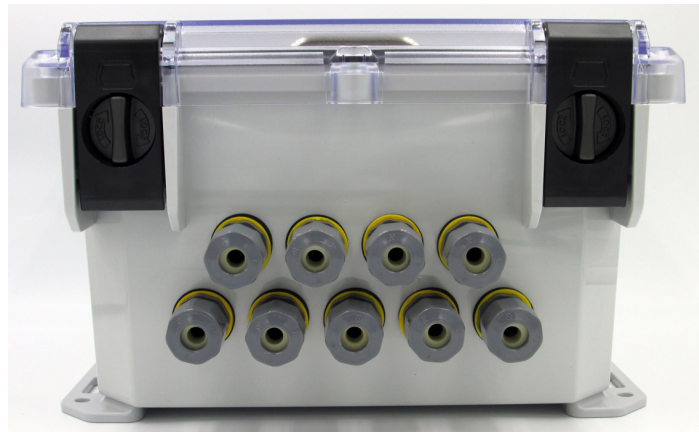

*Top output side with latches have 9 each each 1/2" NPT cable glands factory installed giving a total of 14 each cable glands for the six channel controller (including 14 each sealing caps to cover all cable glands to ensure NEMA 4X rating of assembly when no cables are installed). When ethernet cable is used install the alternate cable gland provided (not shown above).*

The 3 channel and 6 channel controllers with the 7.0" touchscreens are available in configurations which are CSA & UL approved for use in hazardous Class I, Division II locations. AC line powered configurations suitable for hazardous C1D2 areas are the HiQDT-CTRL-6CH-PS1C1D2 & HiQDT-CTRL-3CH-PS1C1D2. For DC powered configuration in hazardous areas use the -PS0 power option where no integral power supply is provided and instead customer supplies a suitable isolated & regulated 24VDC power supply wired directly to the power terminal block on HMI5070L.

**INITIAL COMMISSIONING STEPS:**

1. Provide power to touchscreen controller. Power options are 85-265 VAC (PS1 or PS1C1D2), 18 to 75 VDC (PS2), or 9 to 36 VDC (PS4) power type. **Only PS1C1D2 is suitable for AC powered use in hazardous locations.**
  - a. **If unsure about correct location & power type to be provided to unit consult factory to avoid damage!!**
2. Determine desired configuration of sensor types to be used for each of the available six channels. It is not necessary to setup all sensor channels at time of commissioning. Channels may be added or removed over the course of time if desired. Note any such changes for any upstream connected PLC, DCS or SCADA.
3. Setup sensor with correct node & baudrate for channel w/ Windows software or handheld communicator (HHC)
4. Configure each sensor type from touchscreen controller for the channel to be used.
5. Plug in HiQDT sensors terminated with HiQ4M male snap connector (or extension cable terminating in the same) into one of the available HiQ4FP female panel mount connector. It makes no difference which sensor type or channel is plugged into which port with the HiQDT sensor multi-drop RS-485 MODBUS RTU communications.
6. If commissioning was successful each channel will properly display the sensor type & live values in main screen.
7. Wire up analog outputs and contact relays to be used after configuring them from the appropriate screens.
8. Setup secure remote access with EZAccess 2.0 software. One-time registration is required to Maple Systems.
9. Setup email notifications for trigger events to prompt when remote login might be advisable when not at site.



## INSTALLATION GUIDE

The software in the six (6) channel touchscreen controller is specifically designed to be used with IOTRON™ & ZEUS™ series smart digital HiQDT MODBUS RTU HiQDT pH, ORP, D.O., ISE & EC sensors. All functionality detailed in this manual can also be performed by the ASTI supplied handheld battery powered communicator (**excluding only changing of the baudrate which is only possible using the Windows software**). The Windows software can perform ALL possible operations on the smart digital MODBUS RTU HiQDT pH, ORP, D.O., ISE & EC sensors. The ASTI supplied HiQDT HMI+PLC touchscreen controller package that is a turn-key unit available for purchase ready for plug and play commissioning with a robust software suite. Alternatively any PLC of your choice can be programmed to accomplish the same features if you prefer. If implementing on your own PLC instead of using the ASTI supplied package the software layout can serve as a roadmap for your own installation if you wish. All functions performed by this software can also be accomplished on your own customer supplied PLC with the appropriate modbus function calls (see implementation guide for details) with the exception of setting the node address (Handheld Communicator or Windows software must be used to perform these tasks) or baudrate (only the Windows software must be used to perform this particular task).

The software contains the following **menus** and **fields**, all of which are accessible starting with the main menu.

<u>MENUS</u> (Left Column in the Main Menu):	Page(s)	<u>MENUS</u> (Right Column in the Main Menu):	Page(s)
<b>“Select Channel” menu</b> <ul style="list-style-type: none"> <li>• Set the working channel</li> <li>• Notes about baudrate &amp; node address</li> </ul>	<p>7</p> <p>7</p>	<b>“Hold Channel Output” menu</b> <ul style="list-style-type: none"> <li>• Set channel on hold for maintenance</li> </ul>	<p>28</p>
<b>“Sensor Type” menu</b> <ul style="list-style-type: none"> <li>• Sensor Type</li> <li>• Node Address Scheme for HiQDT Sensors</li> </ul>	<p>8</p> <p>9</p>	<b>“Analog Output Status” menus</b> <ul style="list-style-type: none"> <li>• Configure Analog Output</li> <li>• Scale Analog Outputs</li> <li>• Wiring for Analog Outputs</li> </ul>	<p>29</p> <p>30</p> <p>31</p>
<b>“Calibrate Sensor” menu</b> <ul style="list-style-type: none"> <li>• Display Current Calibrations</li> <li>• Autobuffer Calibrations (pH Sensors Only)                             <ul style="list-style-type: none"> <li>○ pH Buffer A.P. Cal (Offset)</li> <li>○ pH Buffer Acid &amp; Base Slope Cal</li> </ul> </li> <li>• Manual Calibrations                             <ul style="list-style-type: none"> <li>○ ORP Offset Cal</li> <li>○ pH A.P. (Offset) Cal</li> <li>○ Temperature Offset Cal</li> <li>○ pH Acid &amp; Base (Alkaline) Slope</li> <li>○ Ion Selective (ISE) Offset &amp; Slope</li> <li>○ Conductivity (EC) Slope</li> </ul> </li> <li>• Dissolved Oxygen (D.O.) Calibrations</li> <li>• Adjust Dampener Settings</li> <li>• Reset All Calibrations</li> </ul>	<p>10</p> <p>10</p> <p>11</p> <p>11</p> <p>12</p> <p>13</p> <p>13</p> <p>14</p> <p>15</p> <p>16-17</p> <p>18</p> <p>19</p> <p>20-21</p> <p>22</p> <p>22</p>	<b>“Set Output &amp; Relays” menus</b> <ul style="list-style-type: none"> <li>• Enter low &amp; high setpoints for PROCESS setpoints &amp; view status of process relays</li> <li>• Enter low &amp; high setpoints for TEMP setpoints &amp; view status of temp relays</li> <li>• Wiring for Relay Outputs</li> </ul> <b>“MODBUS TCP Slave Registers” menus</b> <ul style="list-style-type: none"> <li>• HiQDT Sensors PROCESS VALUES</li> <li>• HiQDT Sensors CALIBRATION INFO</li> <li>• HiQDT Sensors ANALYTIC INFO</li> <li>• Serial Alpha Chart for Register 40026</li> </ul>	<p>32</p> <p>32</p> <p>33</p> <p>34-37</p> <p>38-40</p> <p>41-42</p> <p>43</p>
<b>“Sensor Diagnostics” menu</b> <ul style="list-style-type: none"> <li>• Snapshot of the current sensor analytic info</li> </ul>	<p>23</p>	<b>“Relay Event Status” menu</b> <ul style="list-style-type: none"> <li>• Shows record of relay On/Off events</li> </ul>	<p>44</p>
<b>“Email Notifications” menus</b> <ul style="list-style-type: none"> <li>• Email Notifications Setup</li> <li>• Email Notifications Menu</li> </ul>	<p>24</p> <p>25</p>	<b>“Remote Access 2.0” menu</b> <ul style="list-style-type: none"> <li>• Initial Setup of remote access feature</li> <li>• Remote client login to controller</li> </ul>	<p>45</p> <p>46</p>
<b>“Controller Info” and “Trend Display” menu</b> <ul style="list-style-type: none"> <li>• Display information about current controller</li> <li>• Hard Reset back to factory defaults</li> <li>• View trending graphs for each channel</li> </ul>	<p>26</p> <p>26</p> <p>27</p>	<b>Miscellaneous</b> <ul style="list-style-type: none"> <li>Download, view logged data (local/remote)</li> <li>Sample Process, Calibration &amp; Analytic Data</li> <li>Appendix “A, B, C, D, E, F &amp; G”</li> <li>Dimensional &amp; Mount Details for Enclosure</li> <li>Software License Agreement (EULA)</li> </ul>	<p>47-49</p> <p>50-52</p> <p>53-62</p> <p>63-66</p> <p>67-68</p>

### Default Home Screen & Main Menu

Default home screen shows live process & temperature values for all connected HiQDT sensors & raw absolute mV values for all channels in controller configuration. If the commissioning steps as detailed in page 4 of this manual were successful completed then sensors added will be shown in this home screen along together with corresponding node address in use for each channel.

If for any reason any of the channels that was setup does not display correctly it is possible to use the “ASTI Windows Datalogging & Graphing Windows Software for 3TX Transmitters with MODBUS Output” to troubleshoot the HiQDT MODBUS sensor configuration. In this case you would temporarily disconnect the D+ & D- input leads to the HMI and temporarily redirect the output to this Windows software (contact factory for assistance). Please refer to the separate manual for this software for instructions on how to configure it for use with the HiQDT sensors for such a purpose.

**Main Menu** is accessible from the home default display screen as shown on top to the right. Exiting from the main menu will load back the default display screen. After a period of inactivity you will also get returned back to the home default display screen.

Subsequent portions of manual detail specific sub-menus or screens that are accessible starting from this main menu. If unsure where as specific menu is located please refer to the table of contents on the previous page five (5).

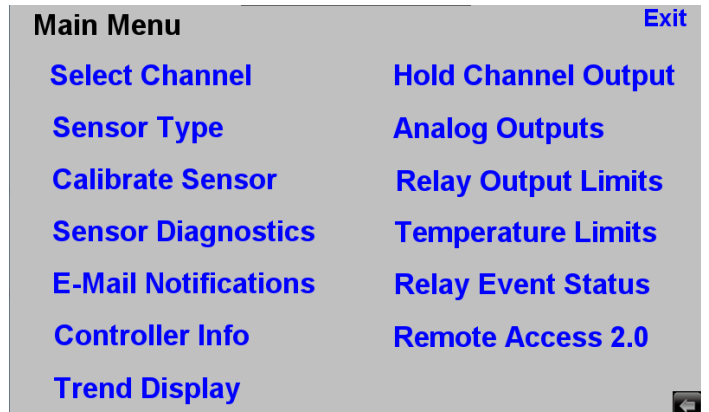
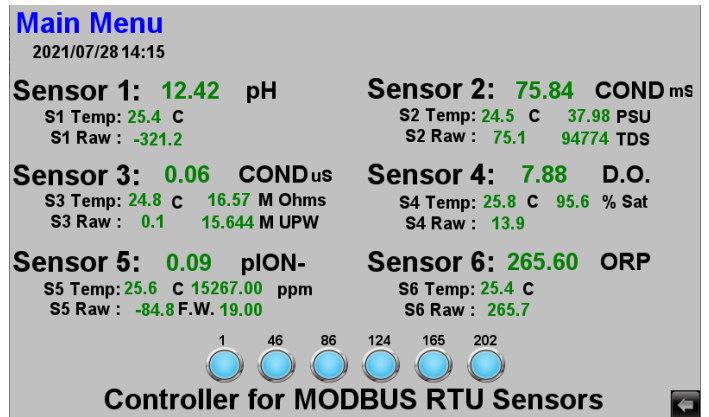

The clickable items in any of the screens is indicated by being shown in **blue** and/or shown as a button.

### Wiring of HiQDT Sensor D+ & D- to HMI5070/HMI5071L on DE9S COM3 (RS-485 2-wire)

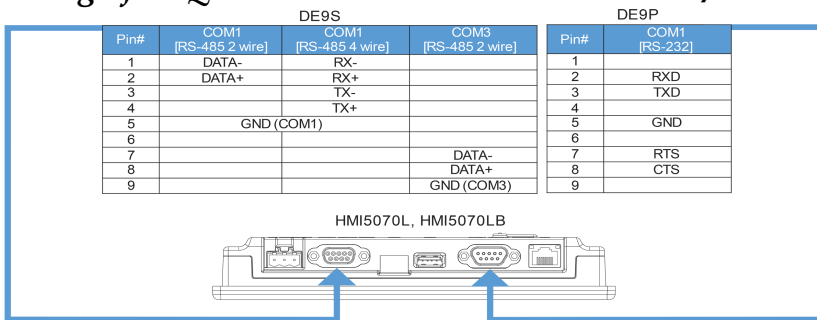

*HMI5070L is suitable for use in hazardous Class I, Division II locations. The white lead(s) from HiQDT sensor(s) are connected to terminal 8 (D+) and green lead(s) from HiQDT sensor(s) are connected to terminal 7 (D-).*

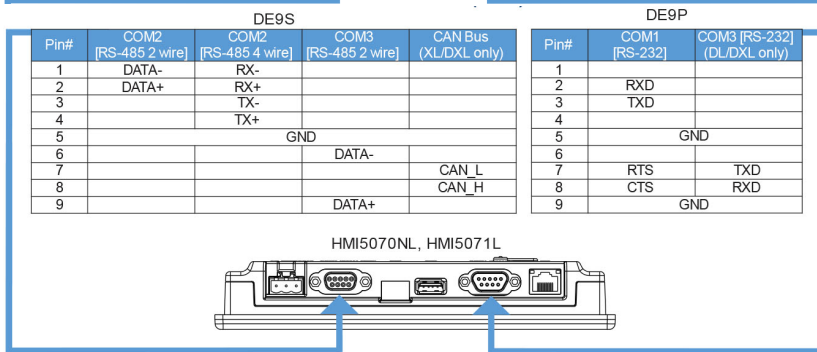

*HMI5071L is only suitable for use in safe non-hazardous locations. The white lead(s) from HiQDT sensor(s) are connected to terminal 9 (D+) and green lead(s) from HiQDT sensor(s) are connected to terminal 6 (D-).*

**Communication between HMI5070/HMI5070L on COM1 DE9P RS-232 port to MLC1-E0808Y0402T on COM1 RJ45 RS232 port is accomplished with factory installed custom cable assembly.**

### “Select Channel” Menu

The select channel is a global setting. Most all tasks to be performed in the remainder of the menu such as sensor type & node address, sensor calibration, setup and scaling of analog output and relays use the channel that is set in this menu.

You must first designate whether you are adding or removing a channel from service. After selecting the channel you can set the sensor type for that channel by clicking on the “[Select Sensor Type](#)” to navigate directly to this screen.

The working channel can be changed by clicking on the number shown in blue which will load a screen where a new channel can be entered. Valid choices are one to six (1 to 6). You will be asked to confirm each channel addition or removal.

If adding a new sensor after designating the channel to which it will be assigned you will then automatically proceed to “[Sensor Type](#)” screen for configuration. The channel number must be designated before the valid node address for the particular sensor type can be appropriately assigned.



### IMPORTANT NOTE ABOUT BAUDRATE:

The default baudrate for all HiQDT sensors to be used with the six channel controller is 19,200 kbps. Default baudrate for the HiQDT sensors is 19,200 unless otherwise requested at time of purchase. If the baudrate is changed to 9,600 kbps on your HiQDT sensor it cannot be used with the ASTI HiQDT touchscreen controller.

**ONLY the ASTI HiQDT Windows software can change the baudrate of the HiQDT smart digital RS-485 MODBUS RTU sensors (see manual for details).**

### IMPORTANT NOTE ABOUT NODE ADDRESS:

The default node address for HiQDT sensors always assumes channel 1. The default node address will always be exactly the same as the sensor type. For pH the sensor type and default node address is 1. For standard range ORP the sensor type and default node address is 2 while for wide range ORP the sensor type and default node address is 3. For dissolved oxygen (D.O.) the sensor type and default node address is 4. For Ion Selective (ISE) the sensor type and default node address is 5. For Conductivity (EC) the sensor type and default node address is 6.

**IMPORTANT NOTE: ONLY the ASTI HiQDT Windows software or the ASTI handheld communicator (HHC) can change the node address of HiQDT smart digital RS-485 MODBUS RTU sensors (see respective manuals for details).**

### ORDERING NOTES:

HiQDT sensors can be ordered with node addresses pre-assigned other than the default values shown above. This is done by adding “-NX” to the end of the part number where X is the node address to be factory assigned. If not special indication is made then the sensor will come with the standard default node address scheme as detailed above. For cases where the sensors are purchased together with the controller a logical preset node scheme will be provided so that all sensors will automatically show up in the home display screen allowing for plug and play operation right out of the box.

### “Sensor Type” Menu

The table at the bottom of this page details the node address that should be assigned for each sensor type depending upon the channel to which it is to be commissioned (installed). This information is also shown in the “Sensor Type” screen as can be seen to the right. Clicking on the sensor type will assign the node address as appropriate for the current working channel that has been previously selected.

#### Sensor type ONLY configured for current channel!!

The sensor type for the current channel can be changed by clicking on available HiQDT sensor types in the dropdown. For each sensor type the correct node address to be assigned is shown for each channel. Be sure that the sensor you plan to use for a given channel has been configured for the correct node address before making the change in the controller configuration. **The node address of sensors can only be changed with the handheld communicator or free of charge Windows software.**

Current working node changes to selection after update sensor button is pushed and confirmed.

[Back](#)

**Select Sensor Type**

Current Working Channel: [ 1 ]  
Current Working Node: [ 0 ]

[Update Sensor](#)

Select Sensor Type	Sensor Address Range
pH	pH (Node 1/41/81/121/161/201)
ORP	ORP (Node 2/42/82/122/162/202)
Wide ORP	Wide ORP (Node 3/43/83/123/163/203)
D.O.	D.O. (Node 4/44/84/124/164/204)
pION	pION (Node 5/45/85/125/165/205)
Conductivity	Conductivity (Node 6/46/86/126/166/206)

[Back](#)

**Conductivity Std/High/Low Scaling Options**

Current Working Channel: [ 2 ]  
Current Working Node: [ 46 ]

Select which reference to use for scaling

[Conductivity EC](#)  
[Computed PSU](#)  
[Computed TDS](#)

**Conductivity Computed TDS Selected**

[Back](#)

**DO ppm/ % Sat Scaling Options**

Current Working Channel: [ 4 ]  
Current Working Node: [ 124 ]

Select which reference to use for scaling

[D.O. ppm](#)  
[D.O. % Sat](#)

**D.O. % Saturation Scaling Selected**

[Back](#)

**Conductivity Ultra Low Scaling Options**

Current Working Channel: [ 3 ]  
Current Working Node: [ 86 ]

Select which reference to use for scaling

[Conductivity EC](#)  
[Mega Ohms](#)  
[Mega Ohms UPW](#)

**Temp Compensated Conductivity Selected**

UNIT NOTE FOR DISSOLVED OXYGEN (DO) SENSORS:  
The unit selected for the dissolved oxygen sensor at time channel is added to controller (ppm or % Saturation) will be the unit used for the analog output, contact relays and trend graph.

UNIT NOTES FOR CONDUCTIVITY (EC) SENSORS:  
The unit selected for the dissolved oxygen sensor at time channel is added to controller (mS/PSU/TDS for standard/high range sensors and uS/MΩ/MΩ-UPW for the utlralow range sensors) will be the unit used for the analog output, contact relays and trend graph.

**Upon making unit selection after adding conductivity or dissolved oxygen sensor the choice will be shown in red text below to indicate that your unit entry was received.**

**Please see Appendix “G” for additional information about the various cell constants and range modes for the conductivity sensors before commissioning.**

**Conductivity sensor MUST be connected PRIOR to adding conductivity channel to the controller!!**





### Node Address Scheme when using with ASTI Touchscreen HiQDT PLC Controller

When HiQDT sensor is used with ASTI Touchscreen HiQDT PLC Controller then node address MUST be set as defined in the table below. If HiQDT sensor & controller are ordered together the node addresses would be preset at factory.

Channel #	1	2	3	4	5	6
Node Range	1-40	41-80	81-120	121-160	161-200	201-240
pH sensor	1	41	81	121	161	201
Standard ORP sensor	2	42	82	122	162	202
Wide Range ORP Sensor	3	43	83	123	163	203
Dissolved Oxygen Sensor	4	44	84	124	164	204
Ion Selective (ISE) Sensor	5	45	85	125	165	205
Conductivity (EC) Sensor	6	46	86	126	166	206
Reserved for future HiQDT sensor types	7-40	47-80	87-120	127-160	167-200	207-240

**COMMISSIONING AND SETUP:**

**ONLY** the ASTI HiQDT Windows software or ASTI Handheld Communicator (HHC) can change the node address of the HiQDT smart digital RS-485 MODBUS RTU sensors (see respective manuals for details).

**SENSOR COMMUNICATIONS:**

If a channel that has been configured loses communications this event will be scrolled across the top of the home screen and written to the system log. If email notifications have been setup an email will also be sent in such an event. Placing a sensor on output hold will not halt the sensor communications warning if it is removed from service.

**SUMMARY OF CORRECT SEQUENCE FOR CALIBRATION OF HiQDT pH SENSOR WITH BUFFERS**

1. Perform temperature calibration (manual mode only)
2. **Select the three pH buffers to be used to perform the calibration (See Appendix A, B & C)**
3. Perform **pH 'Offset'** Calibration (Autoread or Manual) a.k.a. Asymmetric Potential abbreviated as A.P.
4. Perform **pH 'Acid Slope'** Calibration (Autoread or Manual)
5. Perform **pH 'Alkaline Slope'** Calibration (Autoread or Manual) a.k.a. Base Slope
6. If desired, perform adjustment for agreement with laboratory reference value of process grab sample with pH 'Offset' mode. Account for all temperature induced effects if this last step is performed.

**“Calibrate Sensor Menu”**

All sensor calibrations can be shown from the “[Display Current Calibrations](#)” selection. The “[Autobuffer Calibration](#)” is only valid for pH sensors. The “[Manual pH/ORP, pION, Auto DO & Conductivity Calibration](#)” mode is valid for all sensors. “[Adjust Sensor Dampener](#)” and “[Reset All Calibrations](#)” tools are also valid for all sensor types. The “[D.O. Sensor Setup](#)” allows changing salinity and air pressure used to compute percent saturation. For faster calibration operation you can temporarily adjust the sensor dampener to a shorter time than when it is in field use for continuous measurements.

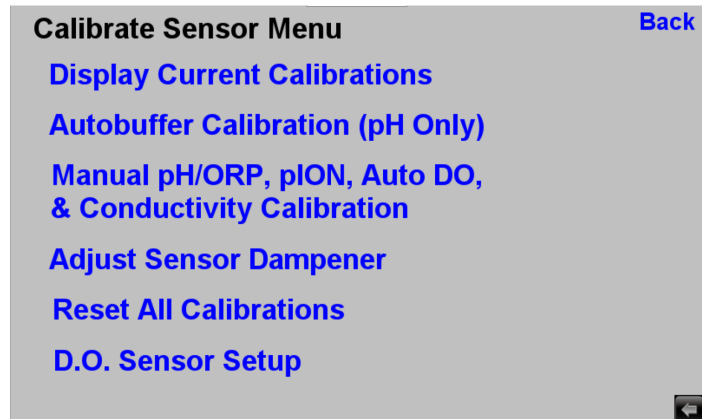

**“Display Sensor Calibrations”**

The calibration values for the sensor in the current working channel can be shown in this screen. Simply click on the Current Working Channel shown in blue and choose the channel that you wish to view if the desired selection is now what is shown. Finally to view the current calibrations then click “[Get Calibrations](#)” button and the values for the selected channel will be shown.

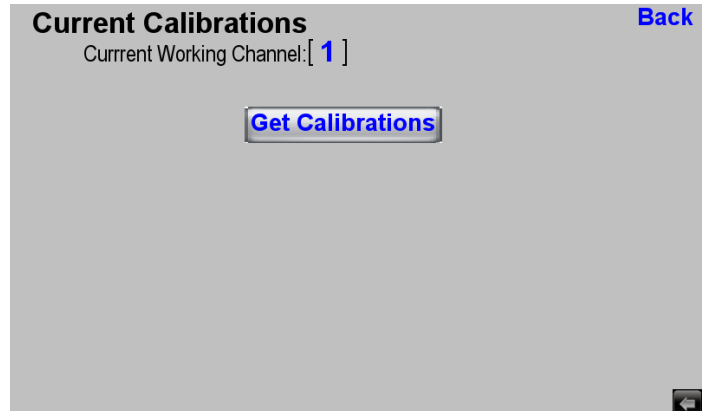

The calibrations will be loaded as appropriate for the given sensor type that is assigned to that channel. In the case shown to the right a calibration was very performed fairly recently and so the time since calibration is shown as 3.17 days. If this display sensor calibrations screen is shown immediately after calibration then the time since calibration should show as 0.0 days instead.

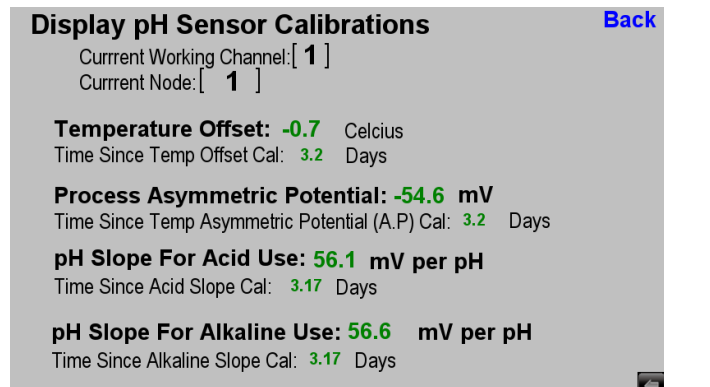

### “Auto Calibrate pH Only” Menu

The autocalibration is only available if the sensor type is pH for the channel to be calibrated. You need only to select the channel for which you wish to perform autobuffer calibration on a pH sensor to begin the process.

You will always start by performing the asymmetric potential (offset) calibration for the pH sensor followed by the acid slope calibration and finally the alkaline slope calibration.

It is recommended to place the channel to be calibrated on output hold before proceeding with the calibration.

### “Auto pH Buffer A.P. Cal”

The current pH and temperature are shown for selected channel in this screen along with the existing currently used asymmetric potential offset calibration as well as the time since this calibration was last performed.

Choices of pH buffer for auto A.P. calibration are 7.00 or 6.86. After selecting buffer click on “Calibrate” button. If calibration is successful then “Calibration Complete” is shown. After dampener time expires the new calibration result will be shown and the time since calibration will show as 0.00 days. The exact value of pH buffer at cal temp shown as “Calibrated Value”.

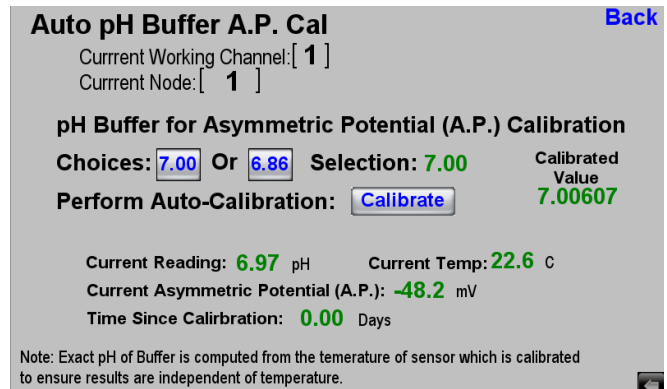
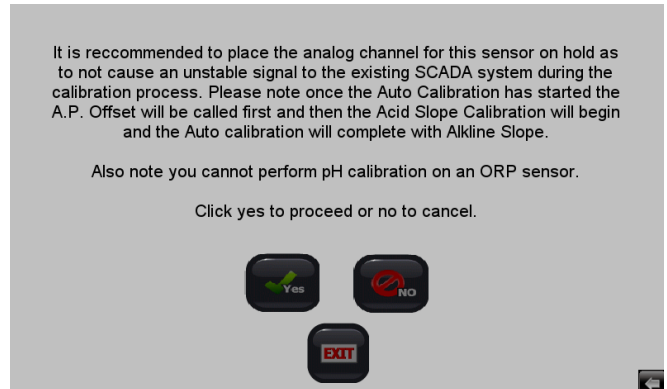
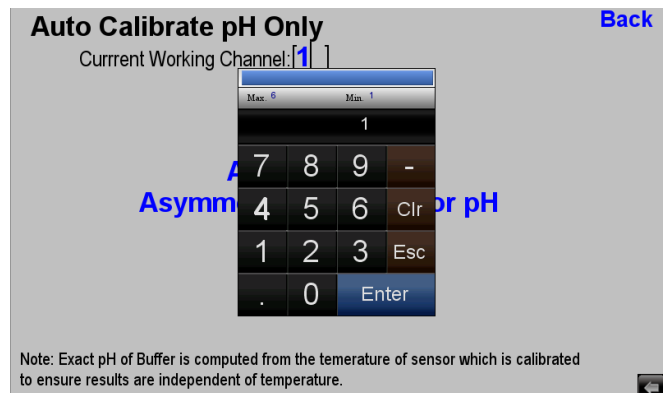
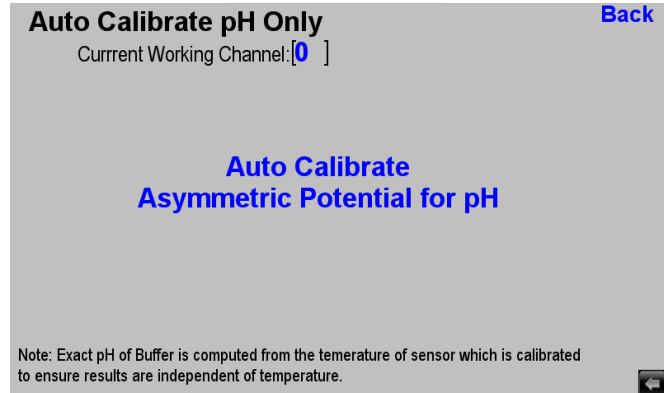

**“Auto pH Acid Slope Calibration”**

The current pH reading and temperature are shown for the selected channel in this screen along with the existing currently used acid slope calibration as well as the time since this calibration was last performed.

Choices of pH buffer for auto acid slope cal are 4.00 or 1.68. After selecting buffer click on “Calibrate” button. If calibration is successful then “Calibration Complete” is shown. After dampener time expires the new calibration result will be shown and the time since calibration will show as 0.00 days. The exact value of pH buffer at cal temp shown as “Calibrated Value”.

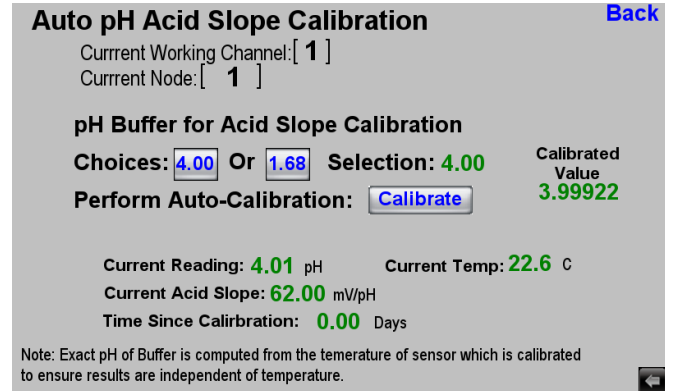

**“Auto pH Base Slope Calibration” Menu**

The current pH reading and temperature are shown for the selected channel in this screen along with the existing currently used alkaline slope calibration as well as the time since this calibration was last performed.

Choices of pH buffer for auto base slope cal are 10.00 or 9.18 or 12.45. After selecting buffer click on “Calibrate” button. If calibration is successful then “Calibration Complete” is shown. After dampener time expires the new calibration result will be shown and the time since calibration will show as 0.00 days. The exact value of pH buffer at cal temp shown as “Calibrated Value”.

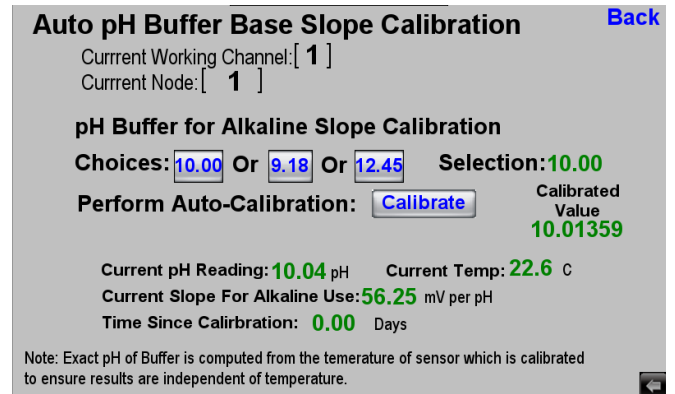

**“Manual Calibrate” Menu**

The available choices for manual calibration of a pH sensor are shown to the right.

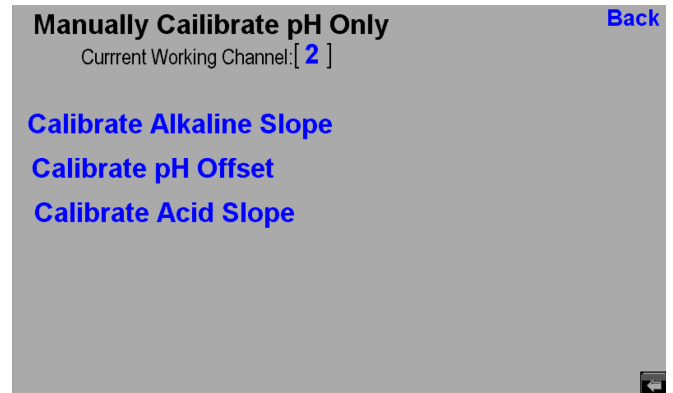

The slope calibration is only available when the sensor type is pH. In addition the pH offset calibration must always be performed before the slope calibrations can be performed.

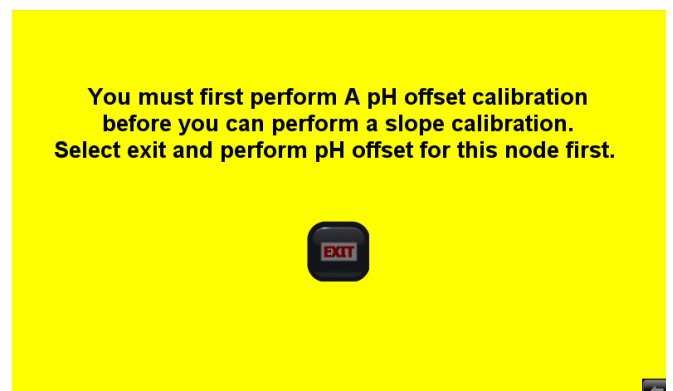

### “Manual Calibrate ORP Offset”

The manual calibration menu options are shown to the right. The ORP offset can be performed with a ORP standard or else used to allow for agreement between the inline process reading and an offline grab sample determination.

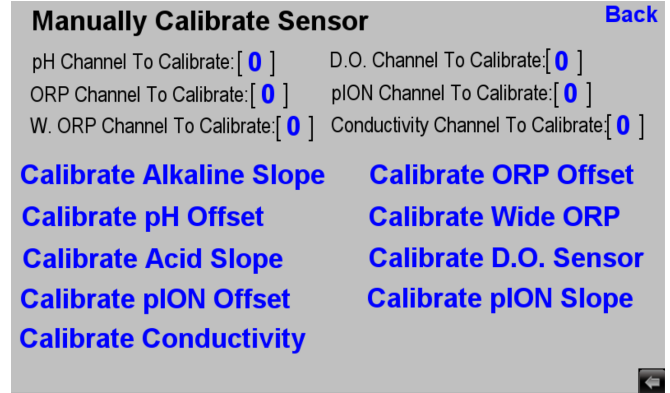

The current ORP reading and temperature are shown for the selected channel in this screen along with the existing current used offset calibration as well as the time since this calibration was last performed.

Enter the value to which you wish to adjust the reading of the ORP sensor. In the case that a ORP standard is used the exact value at the current temperature should be entered. Note that ORP measurements are not temperature compensated but are in fact highly temperature dependent. When calibrating this must be taken into take.

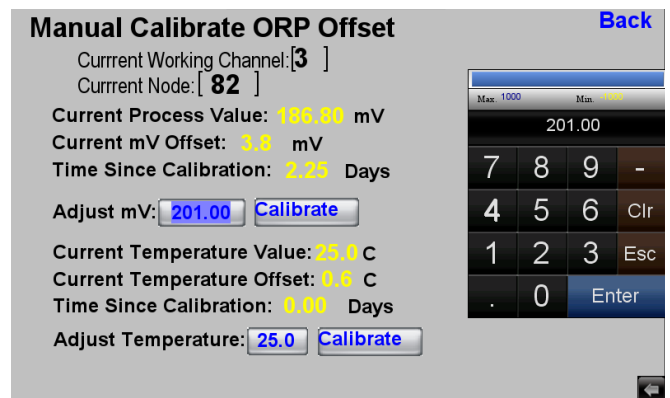

After pressing the “Calibrate” button the screen will display “Calibrating”. If the calibration is successful it will show “Calibrating Complete”. The calibration might not be successful if the calibration limits are exceeded or else is a communication error occurs.

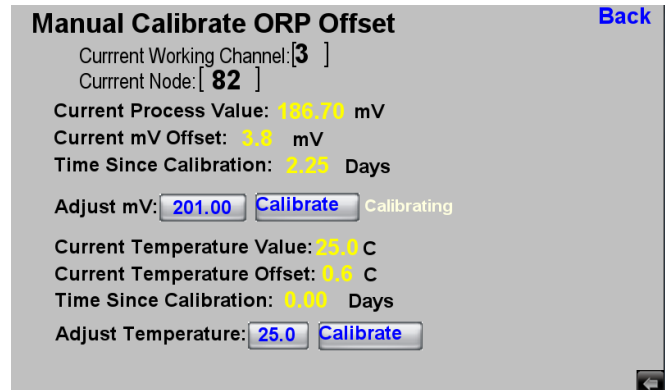

Finally after the dampener time is expired the new calibration results will be shown and the time since calibration will show as 0.00 days. The basic sequence of events after pressing the calibrate button also occurs for the temperature offset calibration as well.

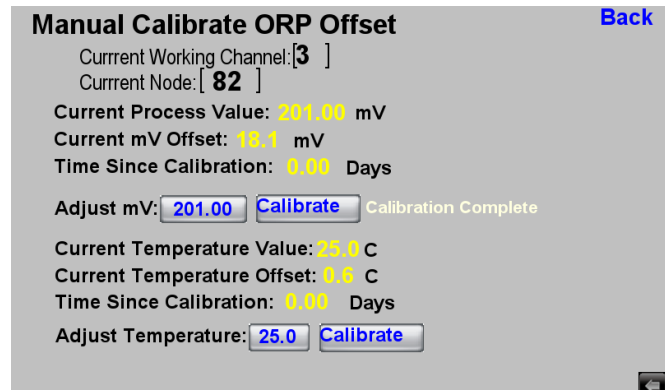

### “Manual Calibrate pH Offset”

The manual calibration pH offset can be performed with a pH buffer or else used to allow for agreement between the inline process reading and an offline grab sample determination. **Such adjustments to a grab sample value should always be done in the ‘Offset’ mode after all pH buffer calibrations are performed.**

The current pH reading and temperature are shown for the selected channel in this screen along with the existing current used asymmetric potential offset calibration as well as the time since this calibration was last performed.

Enter the value to which you wish to adjust the reading of the pH sensor. In the case that a pH buffer is used the exact value at the current temperature should be entered (see appendix “A” and “B” for further details).

After pressing the “Calibrate” button the screen will display “Calibrating”. If the calibration is successful it will show “Calibration Complete”. The calibration might not be successful if the calibration limits are exceeded or else is a communication error occurs.

Finally after the dampener time is expired the new calibration results will be shown and the time since calibration will show as 0.00 days. The basic sequence of events after pressing the calibrate button also occurs for the autobuffer calibrations screens as well as the manual calibration screens.

It is important to recall that the acid slope and base slope calibrations for pH sensors should always be done after performing the offset calibration first. For any type of calibrations to force agreement between the inline process reading and an offline determined value this should ALWAYS be done in the manual offset calibration mode and never in the manual slope calibration mode. Contact factory for assistance if the best practice calibration procedures are in doubt.

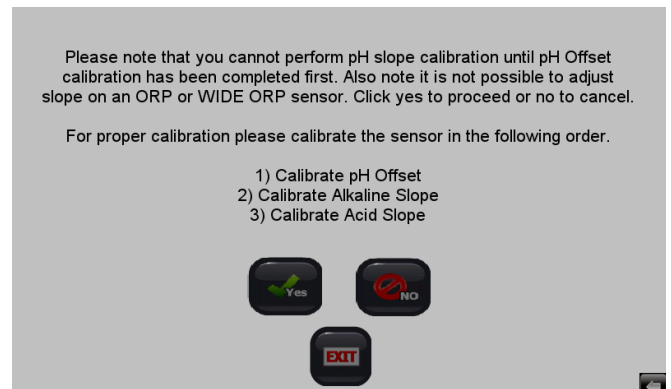
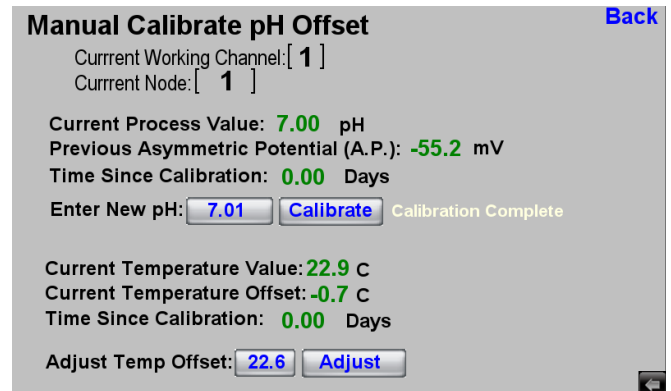
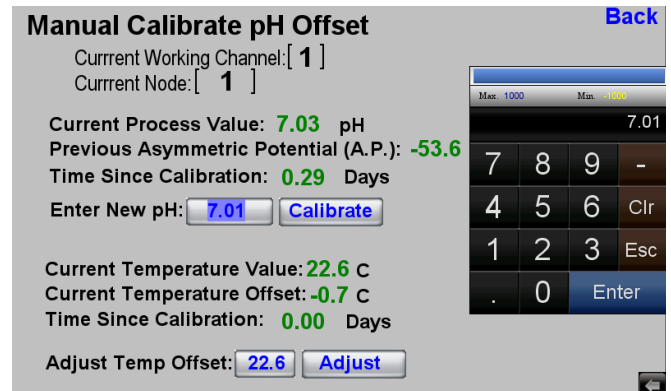
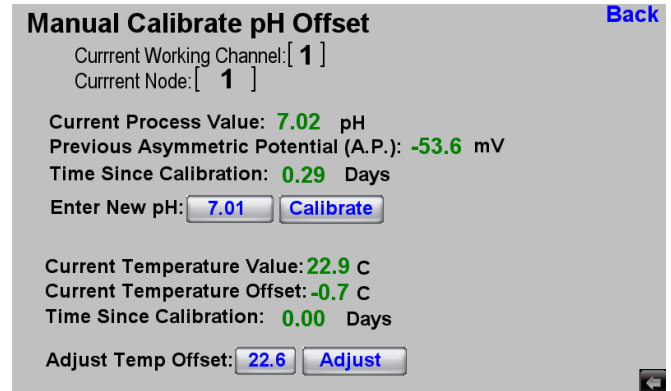

### “Manual Calibrate Temp Offset”

The current pH reading and temperature are shown for the selected channel in this screen along with the existing current used temperature offset calibration as well as the time since this calibration was last performed.

Enter the temperature value to which you wish to adjust the reading of the pH sensor. It is always best practice to calibrate the temperature BEFORE performing any process calibrations.

After pressing the “Calibrate” button the screen will display “Calibrating”. If the calibration is successful it will show “Calibrating Complete”. The calibration might not be successful if the calibration limits are exceeded or else is a communication error occurs.

Finally after the dampener time is expired the new temperature calibration results will be shown and the time since calibration will show as 0.00 days. In the screenshot shown to the right the temperature calibration is shown being perform on a dissolved oxygen (D.O.) type sensor. The temperature calibration screen for the ORP sensor types will look largely similar to the pH offset screen in the screenshot above.

### “Manual Calibrate pH Slope” Menu

Before proceeding to the manual pH slope calibration it is necessary to have previously performed the pH Asymmetric Potential (A.P.) offset calibration first.

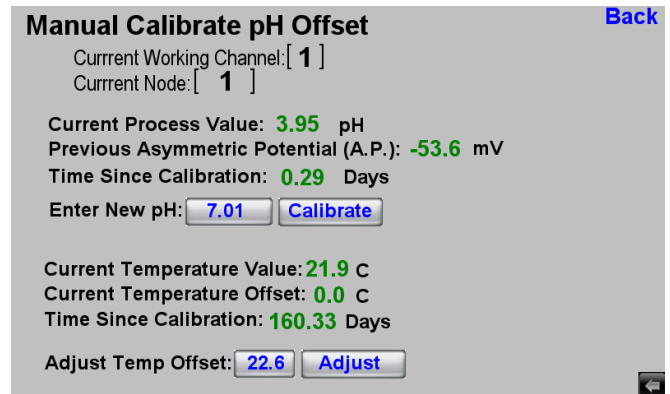

**Manual Calibrate pH Offset** Back

Current Working Channel: [ 1 ]  
Current Node: [ 1 ]

Current Process Value: **3.95** pH  
Previous Asymmetric Potential (A.P.): **-53.6** mV  
Time Since Calibration: **0.29** Days

Enter New pH:

Current Temperature Value: **21.9** C  
Current Temperature Offset: **0.0** C  
Time Since Calibration: **160.33** Days

Adjust Temp Offset:

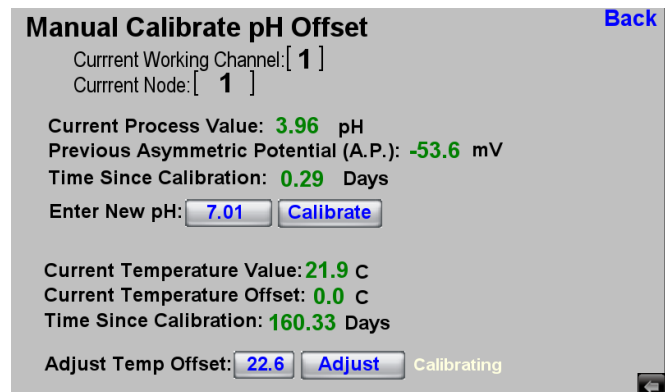

**Manual Calibrate pH Offset** Back

Current Working Channel: [ 1 ]  
Current Node: [ 1 ]

Current Process Value: **3.96** pH  
Previous Asymmetric Potential (A.P.): **-53.6** mV  
Time Since Calibration: **0.29** Days

Enter New pH:

Current Temperature Value: **21.9** C  
Current Temperature Offset: **0.0** C  
Time Since Calibration: **160.33** Days

Adjust Temp Offset:   Calibrating

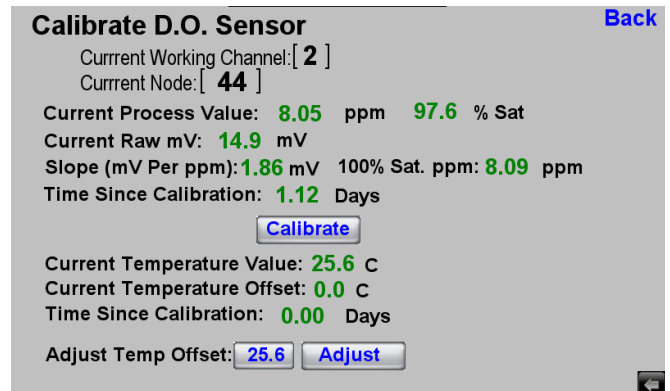

**Calibrate D.O. Sensor** Back

Current Working Channel: [ 2 ]  
Current Node: [ 44 ]

Current Process Value: **8.05** ppm **97.6** % Sat  
Current Raw mV: **14.9** mV  
Slope (mV Per ppm): **1.86** mV 100% Sat. ppm: **8.09** ppm  
Time Since Calibration: **1.12** Days

Current Temperature Value: **25.6** C  
Current Temperature Offset: **0.0** C  
Time Since Calibration: **0.00** Days

Adjust Temp Offset:

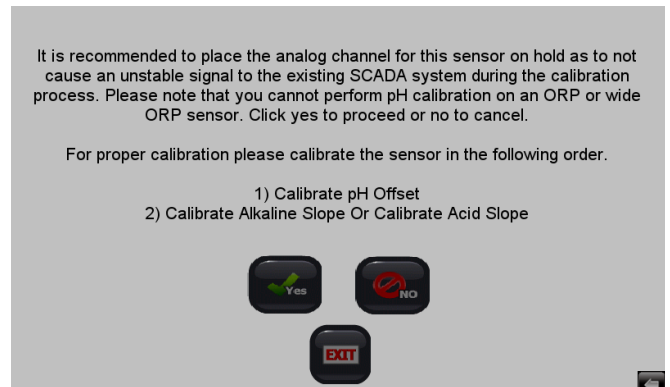

It is recommended to place the analog channel for this sensor on hold as to not cause an unstable signal to the existing SCADA system during the calibration process. Please note that you cannot perform pH calibration on an ORP or wide ORP sensor. Click yes to proceed or no to cancel.

For proper calibration please calibrate the sensor in the following order.

- 1) Calibrate pH Offset
- 2) Calibrate Alkaline Slope Or Calibrate Acid Slope

### “Manual Calibrate pH Slope” Menu - ACID

Select the desired channel where you wish to perform the slope calibration.

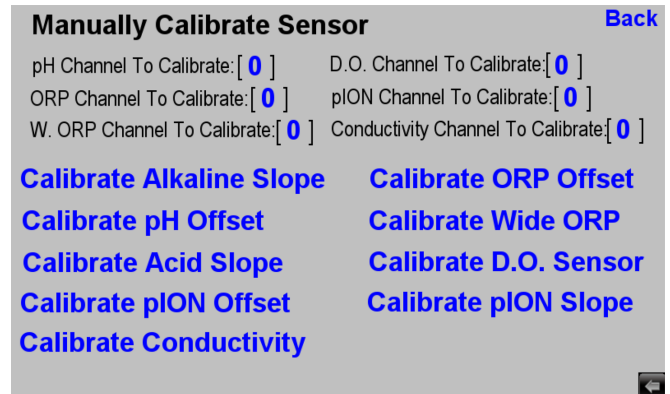

The current pH reading and temperature are shown for the selected channel in this screen along with the existing current used asymmetric potential offset calibration as well as the time since this calibration was last performed.

Enter the value to which you wish to adjust the reading of the pH sensor to perform the acid slope calibration. In the case that a pH buffer is used the exact value at the current temperature should be entered (see appendix “A” and “B” for further details).

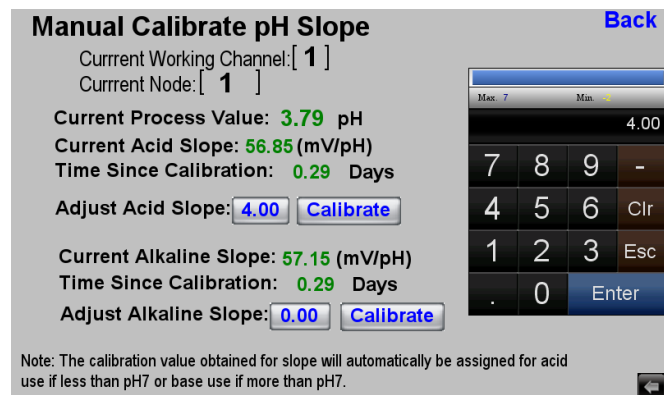

After pressing the “Calibrate” button the screen will display “Calibrating”. If the calibration is successful it will show “Calibration Complete”. The calibration might not be successful if the calibration limits are exceeded or else is a communication error occurs.

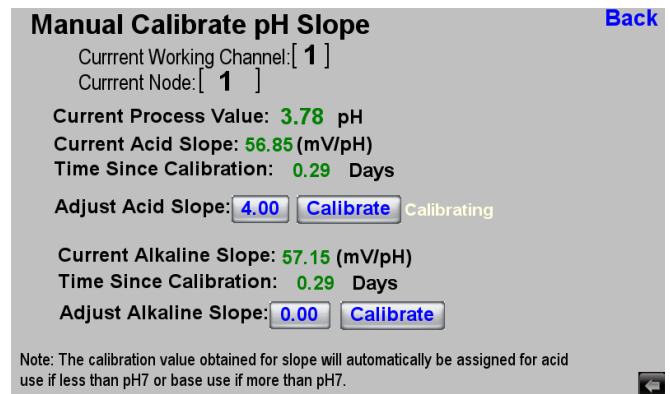

Finally after the dampener time is expired the new calibration results will be shown and the time since calibration will show as 0.00 days. The basic sequence of events after pressing the calibrate button also occurs for the autobuffer calibrations screens as well as the manual calibration screens.

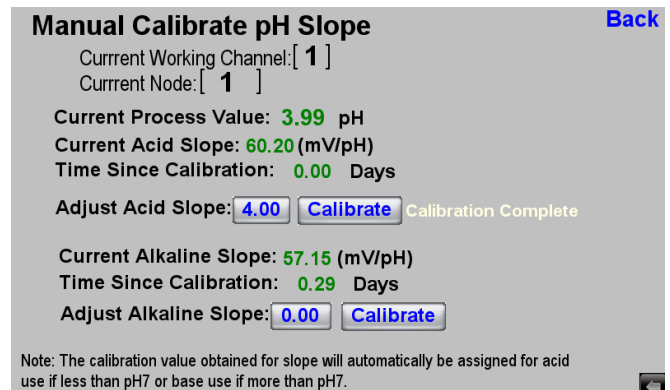



### “Manual Calibrate pH Slope” Menu - BASE

The current pH reading and temperature are shown for the selected channel in this screen along with the existing current used asymmetric potential offset calibration as well as the time since this calibration was last performed.

Enter the value to which you wish to adjust the reading of the pH sensor to perform the acid slope calibration. In the case that a pH buffer is used the exact value at the current temperature should be entered (see appendix “A” and “B” for further details).

After pressing the “Calibrate” button the screen will display “Calibrating”. If the calibration is successful it will show “Calibrating Complete”. The calibration might not be successful if the calibration limits are exceeded or else is a communication error occurs.

Finally after the dampener time is expired the new calibration results will be shown and the time since calibration will show as 0.00 days. The basic sequence of events after pressing the calibrate button also occurs for the autobuffer calibrations screens as well as the manual calibration screens.

It is best practice to view the result of your calibrations to ensure that everything is shown as expected. An example is shown to the right for bringing up the sensor calibration display screen for the channel which was just calibrated in the screenshots showing the various manual offset and slope modes.

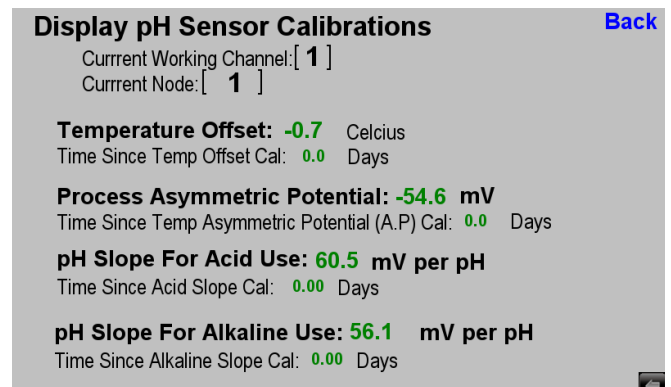
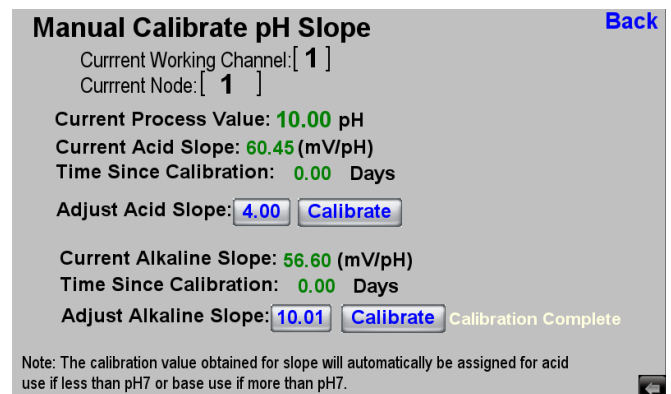
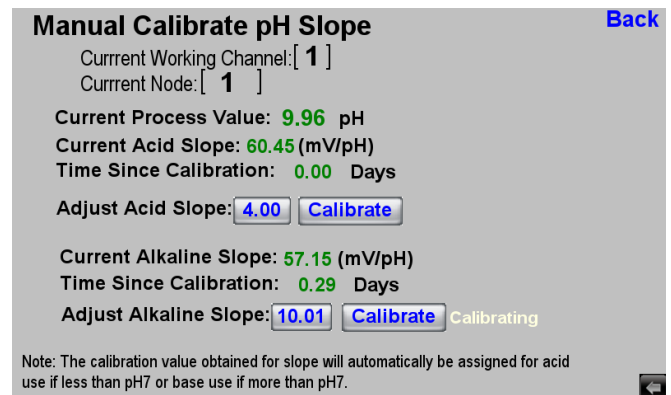
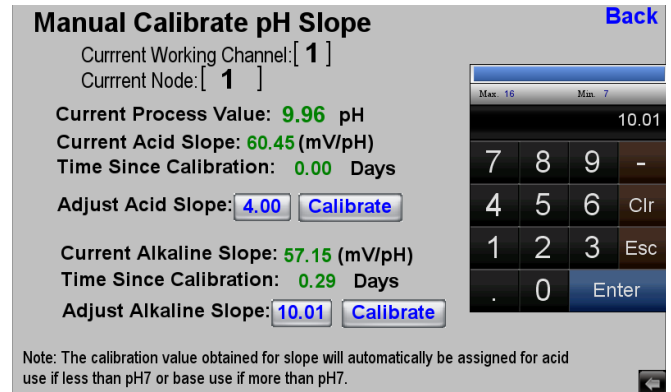

### “Manual Calibrate ISE Offset & Slope”

The manual calibration of the ion selective (ISE) offset can be performed to allow for agreement between the inline process reading and an offline grab sample determination. **Such adjustments to a grab sample value should always be done in the ‘Offset’ mode.**

The ppm reading and temperature shown for selected channel in this screen along with the existing current used asymmetric potential offset calibration as well as the time since this calibration was last performed.

Enter the value to which you wish to adjust the reading of the ISE sensor.

After pressing the “Calibrate” button the screen will display “Calibrating”. If the calibration is successful it will show “Calibration Complete”. The calibration might not be successful if the calibration limits are exceeded or else is a communication error occurs.

Finally after the dampener time is expired the new calibration results will be shown and the time since calibration will show as 0.00 days.

There must exist a timely method to perform a timely grab sample analysis of the process media at installation. A grab sample must be taken and analyzed from the location where sensor is installed. This is typically done using a portable photometer for most ions. Contact the factory for assistance to procure necessary equipment to perform a timely grab sample analysis of the measured sample to enable performing critical offset calibration.

**!!! Before proceeding to the manual ion selective (ISE) slope calibration it is necessary to have previously performed the ISE offset calibration first !!!**

**The use of standard solutions and slope calibrations is only recommended for advanced users that are very, very familiar with all aspects of ion selective sensors, ionic strength adjusters as well as the use of standard addition techniques necessary to successfully performed such calibrations. Contact factory for assistance if you plan to perform slope calibration with standard solutions for assistane.**

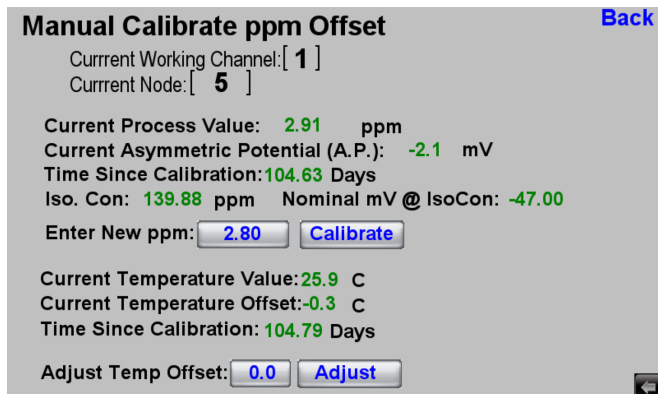

**Manual Calibrate ppm Offset** Back

Current Working Channel: [ 1 ]  
Current Node: [ 5 ]

Current Process Value: 2.91 ppm  
Current Asymmetric Potential (A.P.): -2.1 mV  
Time Since Calibration: 104.63 Days  
Iso. Con: 139.88 ppm Nominal mV @ IsoCon: -47.00

Enter New ppm:

Current Temperature Value: 25.9 C  
Current Temperature Offset: -0.3 C  
Time Since Calibration: 104.79 Days

Adjust Temp Offset:

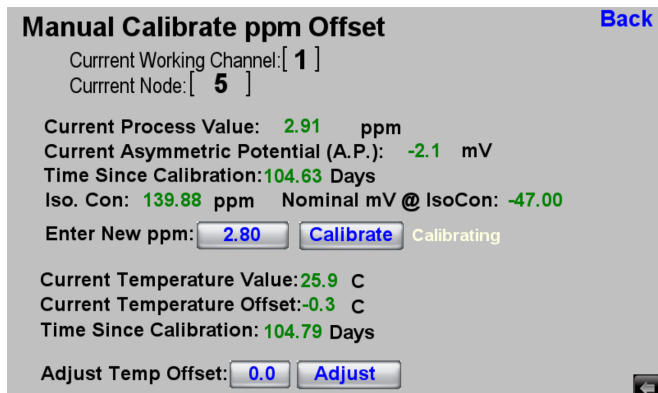

**Manual Calibrate ppm Offset** Back

Current Working Channel: [ 1 ]  
Current Node: [ 5 ]

Current Process Value: 2.91 ppm  
Current Asymmetric Potential (A.P.): -2.1 mV  
Time Since Calibration: 104.63 Days  
Iso. Con: 139.88 ppm Nominal mV @ IsoCon: -47.00

Enter New ppm:   Calibrating

Current Temperature Value: 25.9 C  
Current Temperature Offset: -0.3 C  
Time Since Calibration: 104.79 Days

Adjust Temp Offset:

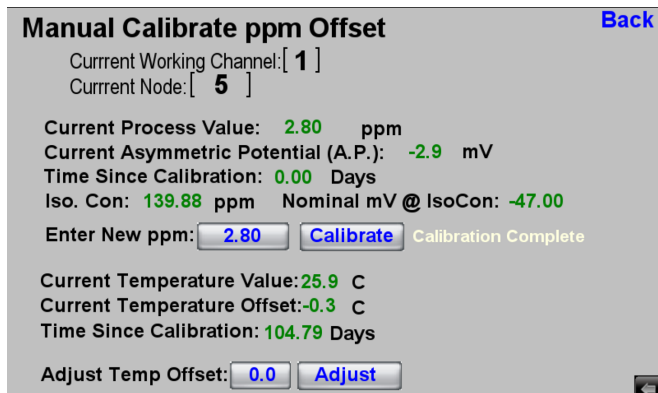

**Manual Calibrate ppm Offset** Back

Current Working Channel: [ 1 ]  
Current Node: [ 5 ]

Current Process Value: 2.80 ppm  
Current Asymmetric Potential (A.P.): -2.9 mV  
Time Since Calibration: 0.00 Days  
Iso. Con: 139.88 ppm Nominal mV @ IsoCon: -47.00

Enter New ppm:   Calibration Complete

Current Temperature Value: 25.9 C  
Current Temperature Offset: -0.3 C  
Time Since Calibration: 104.79 Days

Adjust Temp Offset:

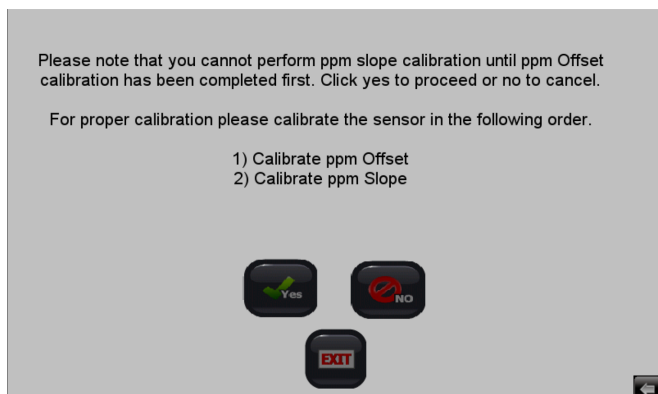

Please note that you cannot perform ppm slope calibration until ppm Offset calibration has been completed first. Click yes to proceed or no to cancel.

For proper calibration please calibrate the sensor in the following order.

- 1) Calibrate ppm Offset
- 2) Calibrate ppm Slope

### “Manual Calibrate Conductivity Slope”

The manual calibration of the conductivity sensor slope can be performed to either allow for agreement between the inline process reading and an offline grab sample determination or else to calibrate to a known conductivity standard solutions. **Such adjustments to a grab sample value should always be done in the ‘Slope’ mode.**

Usual procedure is required to select the conductivity sensor channel that you wish to calibrate before selecting “Calibrate Conductivity” choice from the menu.

Enter the value to which you wish to adjust the reading of the conductivity sensor. The supported calibration slope limits are 0.3000 to 1.700 from the raw conductivity reading of the sensor. The min and max supported values to be entered for the slope calibration are shown for reference purposes to ensure that the entered value does not exceed the permissible limits. **Calibrations are ONLY performed in conductivity units even if computed units are selected as the basis of the analog outputs and relays.**

After pressing the “Calibrate” button the screen will display “Calibrating”. If the calibration is successful it will show “Calibration Complete”. The calibration might not be successful if the calibration limits are exceeded or else is a communication error occurs.

Finally after the dampener time is expired the new calibration results will be shown and the time since calibration will show as 0.00 days.

If the slope calibration is to be used to adjust the inline process reading to an offline determined value of a grab sample from the installed location analysis is typically done with field portable 4-electrode conductivity meter to minimize the time between taking the grab sample and entering the offline determined reference value for the slope calibration as short as possible.

If the conductivity sensor is to be calibrated to a standard solution the channel should be placed on output hold prior to removing the sensor from the process service to avoid any issues with the connected devices using the analog outputs, contact relays or MODBUS TCP outputs.

*Please see Appendix “G” for additional information about conductivity sensors before commissioning.*

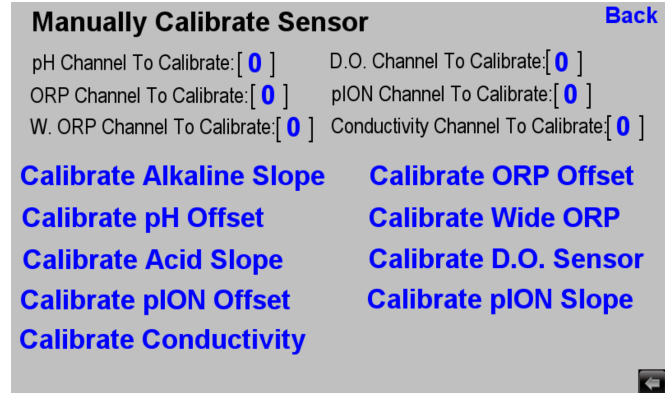

**Manually Calibrate Sensor** Back

pH Channel To Calibrate: [ 0 ]      D.O. Channel To Calibrate: [ 0 ]  
 ORP Channel To Calibrate: [ 0 ]      pION Channel To Calibrate: [ 0 ]  
 W. ORP Channel To Calibrate: [ 0 ]      Conductivity Channel To Calibrate: [ 0 ]

[Calibrate Alkaline Slope](#)      [Calibrate ORP Offset](#)  
[Calibrate pH Offset](#)      [Calibrate Wide ORP](#)  
[Calibrate Acid Slope](#)      [Calibrate D.O. Sensor](#)  
[Calibrate pION Offset](#)      [Calibrate pION Slope](#)  
[Calibrate Conductivity](#)

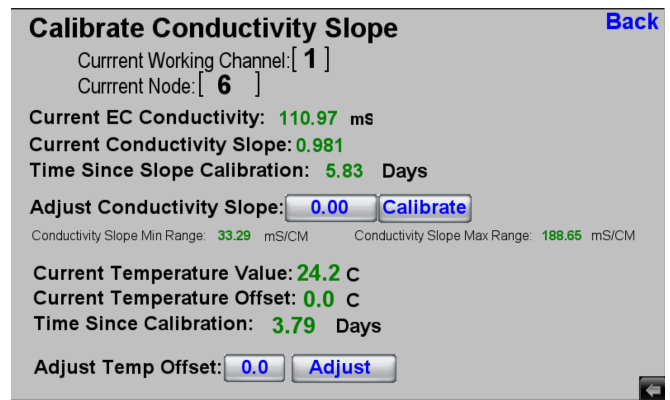

**Calibrate Conductivity Slope** Back

Current Working Channel: [ 1 ]  
 Current Node: [ 6 ]

Current EC Conductivity: 110.97 ms  
 Current Conductivity Slope: 0.981  
 Time Since Slope Calibration: 5.83 Days

Adjust Conductivity Slope:  [Calibrate](#)

Conductivity Slope Min Range: 33.29 mS/CM      Conductivity Slope Max Range: 188.65 mS/CM

Current Temperature Value: 24.2 C  
 Current Temperature Offset: 0.0 C  
 Time Since Calibration: 3.79 Days

Adjust Temp Offset:  [Adjust](#)

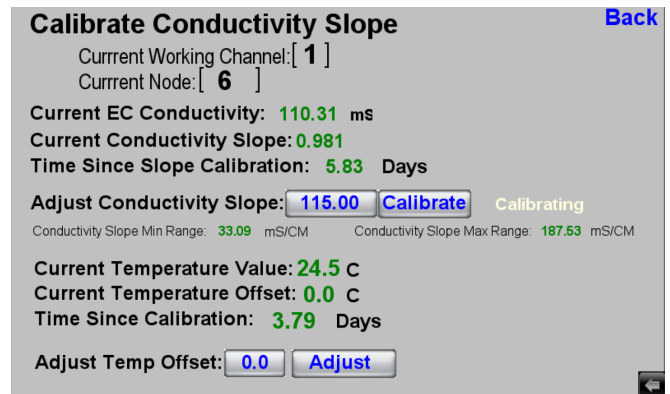

**Calibrate Conductivity Slope** Back

Current Working Channel: [ 1 ]  
 Current Node: [ 6 ]

Current EC Conductivity: 110.31 ms  
 Current Conductivity Slope: 0.981  
 Time Since Slope Calibration: 5.83 Days

Adjust Conductivity Slope:  [Calibrate](#) Calibrating

Conductivity Slope Min Range: 33.09 mS/CM      Conductivity Slope Max Range: 187.53 mS/CM

Current Temperature Value: 24.5 C  
 Current Temperature Offset: 0.0 C  
 Time Since Calibration: 3.79 Days

Adjust Temp Offset:  [Adjust](#)

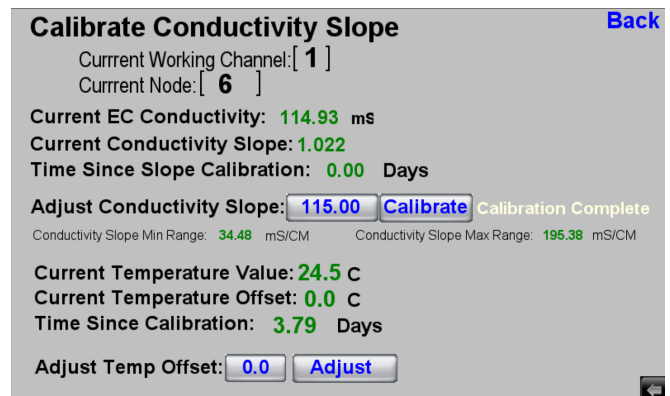

**Calibrate Conductivity Slope** Back

Current Working Channel: [ 1 ]  
 Current Node: [ 6 ]

Current EC Conductivity: 114.93 ms  
 Current Conductivity Slope: 1.022  
 Time Since Slope Calibration: 0.00 Days

Adjust Conductivity Slope:  [Calibrate](#) Calibration Complete

Conductivity Slope Min Range: 34.48 mS/CM      Conductivity Slope Max Range: 195.38 mS/CM

Current Temperature Value: 24.5 C  
 Current Temperature Offset: 0.0 C  
 Time Since Calibration: 3.79 Days

Adjust Temp Offset:  [Adjust](#)

### “Auto Calibrate D.O. Sensor” Menu - Temperature

You need to select the channel for which you wish to perform the fully automated dissolved oxygen sensor calibration. If you are not sure prefer to the main screen as it will display on what channel D.O. sensor(s) have been configured.

The usual caveats apply before performing calibration on you dissolved oxygen (D.O.) sensor. The channel that will be calibrated should be placed on hold prior to performing the calibration especially if the values obtained from the sensor are used for any type of real-time closed loop control purposes.

The D.O. sensor should be at thermal equilibrium before proceeding and be clean and dry, suspended over a source of water in cases of low humidity at the location where the sensor is to be calibrated.

The TEMPERATURE should always be CALIBRATED FIRST on the dissolved oxygen sensor. The reason is that the temperature is used as the main basis of obtaining the dissolved oxygen ppm value for the current dry in air condition used as the basis of the automated calibration routine. If the temperature is not stable before proceeding and not well calibrated you can obtain suboptimal results when calibrating the D.O. sensor in the field.

Finally after the dampener time is expired the new temperature calibration results will be shown and the time since calibration will show as 0.00 days. Following the instructions on the following page to proceed onto the calibration of the dissolved oxygen ppm reading for the process value next.

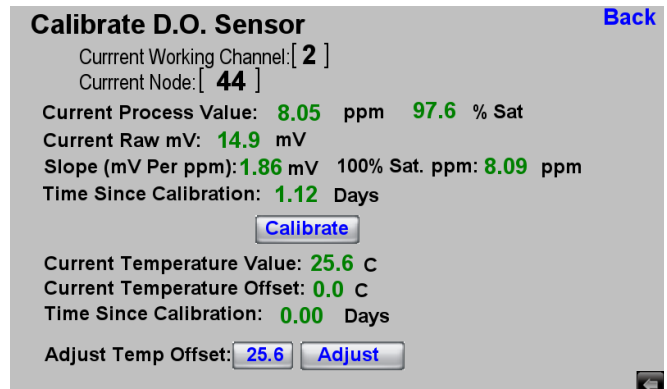
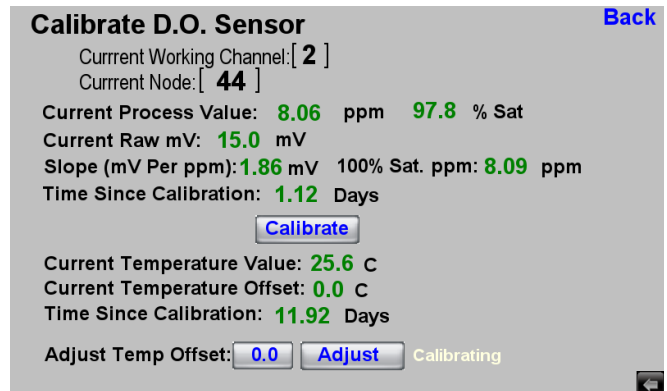
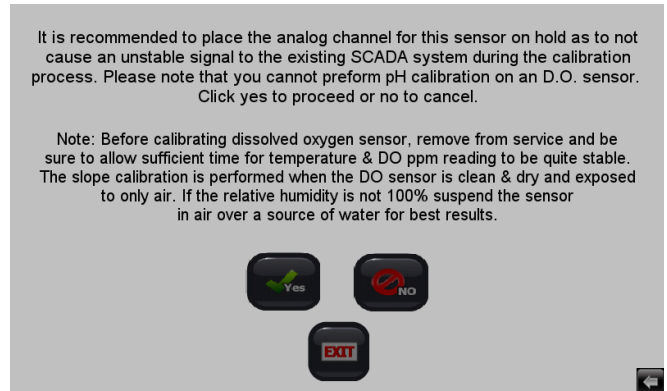

### “Auto Calibrate D.O. Sensor” Menu – Dissolved Oxygen PPM readings

The current dissolved oxygen ppm readings, computed percent saturation values and temperature readings are shown for selected channel in this screen along with the existing currently slope calibration value as well as the time since this calibration was last performed.

The smart digital HiQDT MODBSU RTU dissolved oxygen sensors automatically compute the current dissolved oxygen ppm value for the current dry in air conditions using the temperature and ambient air pressure as the basis.

Click on the “Calibrate” button to start the fully automated calibration procedure. If calibration is successful then “Calibration Complete” is shown. After dampener time expires the new calibration result will be shown and the time since calibration will show as 0.00 days. The exact value of pH buffer at cal temp shown as “Calibrated Value”.

*NOTE 1: The percent saturation value shown on this calibration screen (register 30006 from the HiQDT D.O. sensor) may differ from the percent saturation value that is shown on the main display. The percent (%) saturation value that is computed and shown in the calibration screen excludes the salinity correction since this is not appropriate during the dry in air calibration process of the sensor. The percent (%) saturation that is computed and displayed in the main screen (as well as the basis for all analog & digital outputs and relays) including the salinity correction. The ambient air pressure that is user entered is always used when computing the percent (%) saturation value in all modes.*

*NOTE 2: Review “Appendix E & F” for details about how percent (%) saturation is computed from measured dissolved oxygen ppm and temperature values as well as the user entered air pressure and salinity.*

It is best practice to view the result of your calibrations to ensure that everything is shown as expected. An example is shown to the right for bringing up the sensor calibration display screen for the channel which was just calibrated in the screenshots showing the calibration of the dissolved oxygen sensor.

The “D.O. sensor Set Up” allows for user entered values for the salinity of the measured solution and the ambient air pressure where at the installation site.

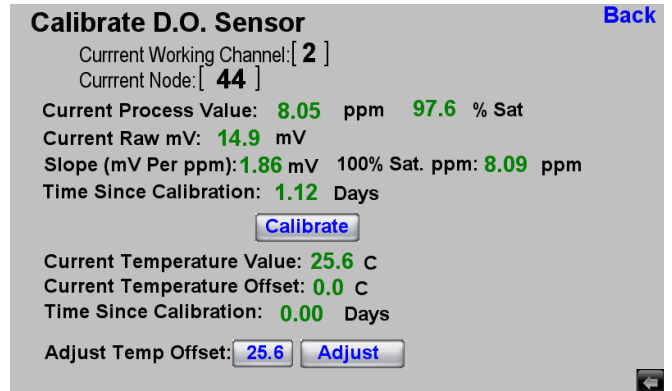

**Calibrate D.O. Sensor** Back

Current Working Channel: [ 2 ]  
Current Node: [ 44 ]

Current Process Value: **8.05** ppm **97.6** % Sat  
Current Raw mV: **14.9** mV  
Slope (mV Per ppm): **1.86** mV 100% Sat. ppm: **8.09** ppm  
Time Since Calibration: **1.12** Days

Current Temperature Value: **25.6** C  
Current Temperature Offset: **0.0** C  
Time Since Calibration: **0.00** Days

Adjust Temp Offset:

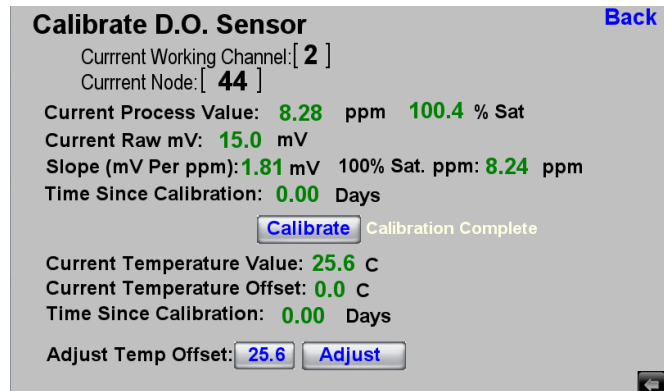

**Calibrate D.O. Sensor** Back

Current Working Channel: [ 2 ]  
Current Node: [ 44 ]

Current Process Value: **8.28** ppm **100.4** % Sat  
Current Raw mV: **15.0** mV  
Slope (mV Per ppm): **1.81** mV 100% Sat. ppm: **8.24** ppm  
Time Since Calibration: **0.00** Days

Calibration Complete

Current Temperature Value: **25.6** C  
Current Temperature Offset: **0.0** C  
Time Since Calibration: **0.00** Days

Adjust Temp Offset:

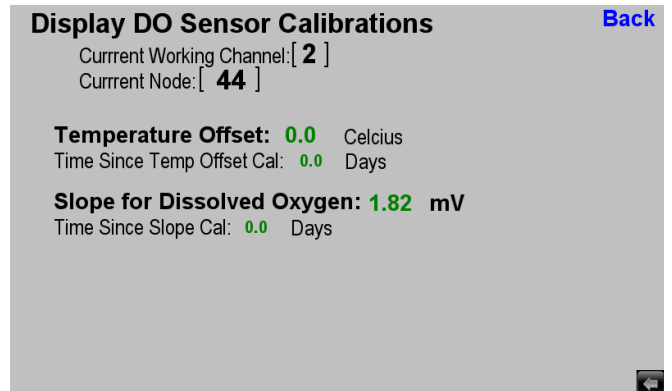

**Display DO Sensor Calibrations** Back

Current Working Channel: [ 2 ]  
Current Node: [ 44 ]

**Temperature Offset: 0.0** Celcius  
Time Since Temp Offset Cal: **0.0** Days

**Slope for Dissolved Oxygen: 1.82** mV  
Time Since Slope Cal: **0.0** Days



**D.O. Sensor Set Up** Back

Select D.O. Channel To Set Up: [ 2 ]  
Current Node: [ 44 ]

Salinity for DO : **12.20** PSU   
Air Pressure fo DO: **760** mmHg

Calibration Complete

**“Adjust Sensor Dampener” Menu**

The available choices for sensor dampener of of the sensor are shown to the right.

It can be desirable to reduce the dampening time before performing calibration to expedite the calibration process.

BE SURE TO RETURN THE DAMPENER BACK TO THE APPROPRIATE HIGHER VALUES FOR USE IN CONTINUOUS FIELD USE IF YOU RETURN THE DAMPENER FOR FASTER CALIBRATIONS.

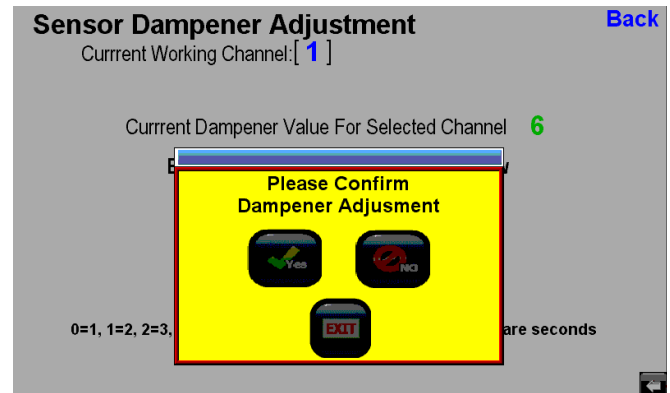
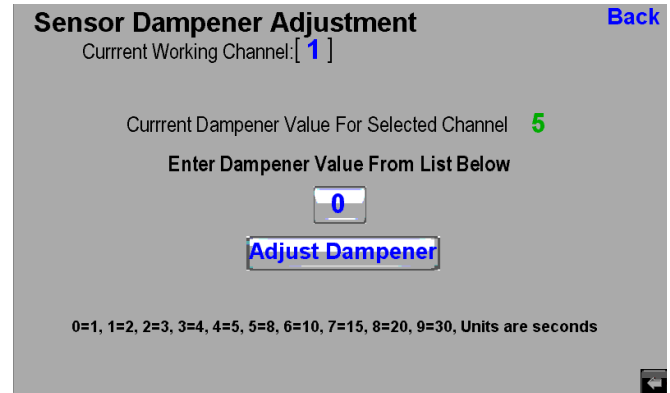

**“Reset All Calibrations” Menu**

This will reset ALL available calibrations back to the values at time of dispatch from the factory.

Once the reset all calibrations call has been performed it cannot be undone. With this in mind please be sure that you wish to reset the calibrations before proceeding.

You may be asked to reset the calibrations on your sensor as part of a troubleshooting in case you have unusual calibration results.

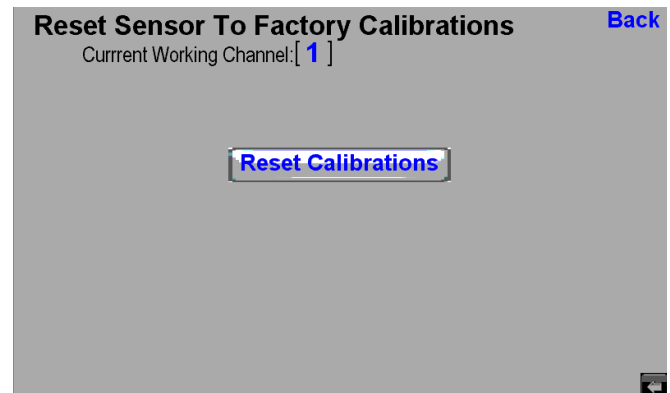

### “Sensor Diagnostics” Menu

**Sensor Diagnostics** Back

Current Working Channel: [ 1 ]

**Get Sensor Info**

Year Manufactured: 21	Sensor Type: pH
Month Manufactured: 7	Software Rev#: 8
Date Manufactured: 21	Item Number: 1616
Serial Number Year: 21	Min Temperature: 25.4
Serial Number Month: 7	Max Temperature: 25.4
Serial Number Letter: dd	Days In Service: 7.2
Serial Number: 123	Dampener Delay: 10

**Sensor Diagnostics** Back

Current Working Channel: [ 2 ]

**Get Sensor Info**

Year Manufactured: 21	Sensor Type: COND
Month Manufactured: 7	Software Rev#: 0
Date Manufactured: 23	Item Number: 23998
Serial Number Year: 21	Min Temperature: 21.7
Serial Number Month: 7	Max Temperature: 24.8
Serial Number Letter: CC	Days In Service: 5.1
Serial Number: 126	Dampener Delay: 1
Cell Constant: 10.00	Cond. Range Mode: 2000

**Sensor Diagnostics** Back

Current Working Channel: [ 3 ]

**Get Sensor Info**

Year Manufactured: 21	Sensor Type: COND
Month Manufactured: 4	Software Rev#: 0
Date Manufactured: 16	Item Number: 23009
Serial Number Year: 21	Min Temperature: 20.2
Serial Number Month: 4	Max Temperature: 27.3
Serial Number Letter: CC	Days In Service: 20.0
Serial Number: 247	Dampener Delay: 10
Cell Constant: 0.01	Cond. Range Mode: 2

**Sensor Diagnostics** Back

Current Working Channel: [ 4 ]

**Get Sensor Info**

Year Manufactured: 21	Sensor Type: D.O.
Month Manufactured: 1	Software Rev#: 5
Date Manufactured: 20	Item Number: 18022
Serial Number Year: 21	Min Temperature: 25.3
Serial Number Month: 1	Max Temperature: 25.8
Serial Number Letter: d	Days In Service: 17.3
Serial Number: 134	Dampener Delay: 10

**Sensor Diagnostics** Back

Current Working Channel: [ 5 ]

**Get Sensor Info**

Year Manufactured: 20	Sensor Type: pION -
Month Manufactured: 6	Software Rev#: 5
Date Manufactured: 18	Item Number: 1586
Serial Number Year: 20	Min Temperature: 25.3
Serial Number Month: 6	Max Temperature: 210.0
Serial Number Letter: E	Days In Service: 173.2
Serial Number: 13	Dampener Delay: 10
	Formula Weight: 19.00

**Sensor Diagnostics** Back

Current Working Channel: [ 6 ]

**Get Sensor Info**

Year Manufactured: 21	Sensor Type: ORP
Month Manufactured: 7	Software Rev#: 4
Date Manufactured: 21	Item Number: 1452
Serial Number Year: 21	Min Temperature: 25.4
Serial Number Month: 7	Max Temperature: 30.7
Serial Number Letter: dd	Days In Service: 5.0
Serial Number: 124	Dampener Delay: 10

Date Stamps:

- Year Manufacture                      Range from 18 for 2018 up to 99 for 2099
- Month Manufactured                  Range from 1 for January to 12 for December
- Date Manufactured                    Release date for sensor in year and month of manufacture

Sensor Statistics:

- Sensor Serial Number:              Complete traceability of given sensor – Broken up into three separate fields:
  - Serial Number Month              Range from 1 for January to 12 for December
  - Serial Number Letter              Range from “A to Y” for single letter Alpha and “AA to nY” dual letter Alpha
  - Serial Number                      Range from 00 to 99 for given alpha character block
- Type:                                      pH, ORP, DO, ISE or EC (COND) depending upon connected sensor
- Software Revision:                    Firmware on sensor board (contact factory to ensure most current version)
- Item Number:                            Completely defines all features and capabilities of given sensor

Temperature Peak Values:

- Min Temperature:                      Lowest temp (°C) experienced by sensor after manufacture date when energized
- Max Temperature:                      Highest temp (°C) experienced by sensor after manufacture date when energized

Field Use Time & Dampener Setting:

- Integral Time Tracking:              The total days the HiQDT sensor has been energized after manufacture date
- Dampener:                                Number of seconds used to smooth the process value reading from sensor

## “Email Notifications” Setup

An email notification will be sent for all users that have been properly setup whenever any relay event is triggered. The SMTP configuration file must be prepared from the Administrator Tools in the EZware Plus Downloaded software. This software is provided on the 32GB USB flash drive connected to the HMI5070 touchscreen of the controller. To the right is shown the typical software utilities that are provided at time of dispatch from the factory. It is recommended to copy them to a safe location to backup and archival purposes. Install the EZware Plus Downloader software.

Navigate to the Maintenance tab in this software and click on the Administrator Tools

Complete the setup of the eMail SMTP server settings

Complete the eMail Contacts.

Choose the “Save to USB” option in the bottom right of the Administrator Tools. Please be sure to have the USB flash drive that was provided with the HiQDT touchscreen controller into the Windows PC where this software is being used. You will need to connect this USB flash drive back into the controller before proceeding to the following page to complete setup of the Email notifications.

HiQDT Touchscreen Controller Software > USB Flash Drive > ASTI

Name	Date modified	Type	Size
ASTI_3TX_Datalogger-2.7	2/14/2019 3:31 PM	Application	2,731 KB
ASTI_Smart_RTU_Sensor_Setup-1.12	2/8/2019 5:34 AM	Application	2,639 KB
EZAccess_setup-2.6.24	1/7/2019 2:37 PM	Application	55,201 KB
EZwarePlusDownloader	1/16/2019 7:23 AM	Application	376,289 KB
VNC-Viewer-6.19.107-Windows	2/14/2019 3:29 PM	Application	10,315 KB

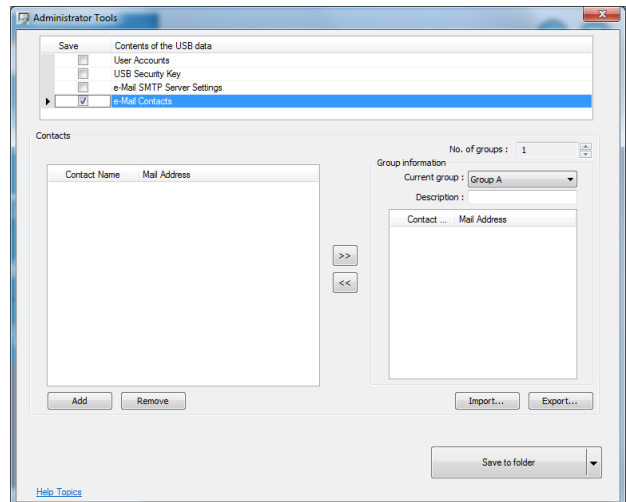
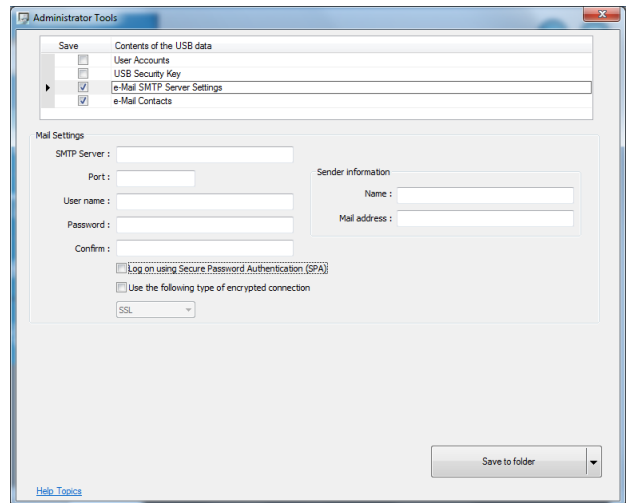



### *“Email Notifications” Menu*

The default view of the Email Calibration Triggers screen is shown to the right. This will have a value of “0” shown for the Import SMTP Settings.

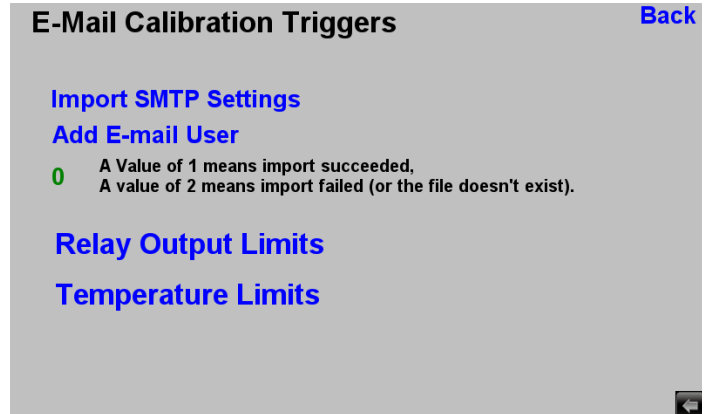

Click on the “Import SMTP Settings” when you have connected the USB flash drive with the email and SMTP setup from the Administrator tools portion of the EZware Plus Downloader software (see previous page for details). If the import is successful you will see a “1” as shown in the screen to the right.

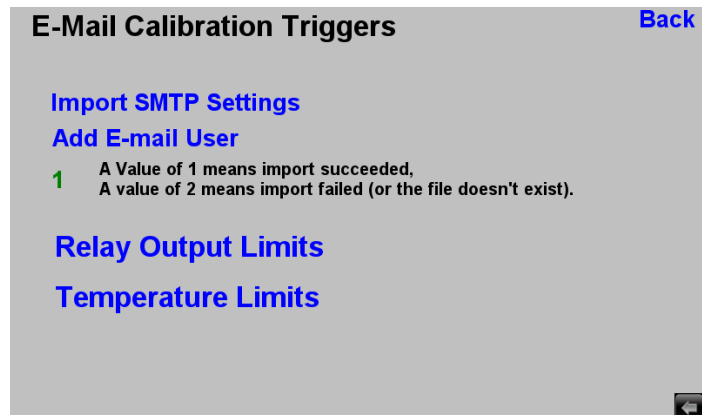

While the setup of the SMTP settings must be done with the Administrator tools portion of the EZware Plus Downloader software and imported from the USB flash drive, it is possible to add and delete users from “Add E-mail User” screen accessible from this “E-mail Calibration Triggers” screen. The interface that is loaded is shown to the right.

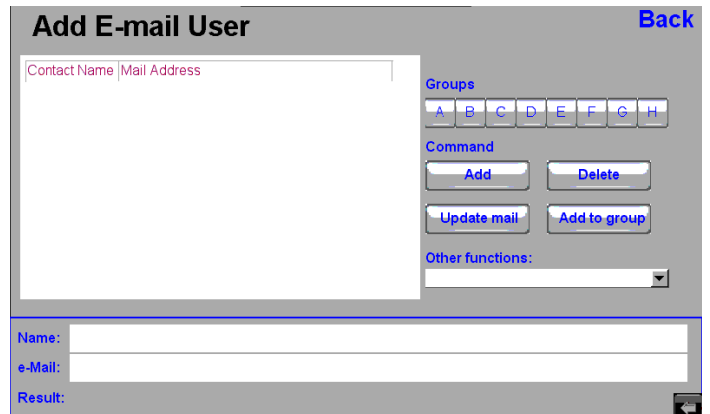

### “Controller Info” Menu

The system time and date is shown based upon what was loaded at the factory at time of dispatch.

The warranty period for the controller begins from the ship date from factory which is indicated by the serial number that is assigned on the label. You may be asked to give the software revision number and build date as displayed in this “Controller Info” screen for support and diagnostic purposes.

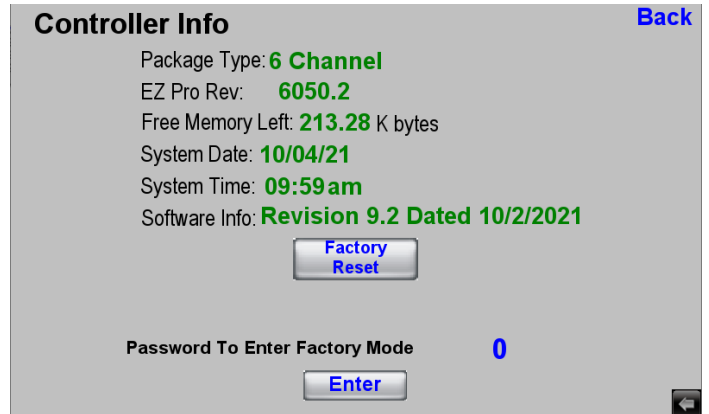

If your local time zone differs use the onscreen tools to adjust the time as appropriate to obtain the correct local time.

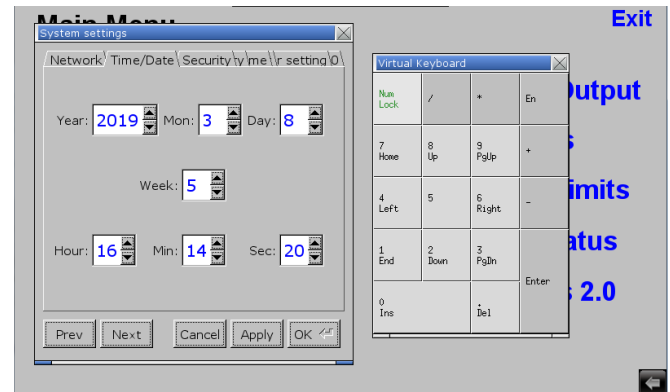

There exists a “Factory Reset” button available from this “Controller Info” screen. You must confirm resetting the controller back to factory default values.

**NOTE THAT THE FACTORY RESET FOR ALL MEMORY REGISTERS CANNTO BE UNDONE! PLEASE CONSULT WITH FACTORY BEFORE INVOKING THIS FACTORY RESET.**

All settings are stored in retentive registers to allow for configuration to be maintained in the event of a power loss or planned shutdown (with the sole exception of the time delay for the alarms which will revert back to zero).

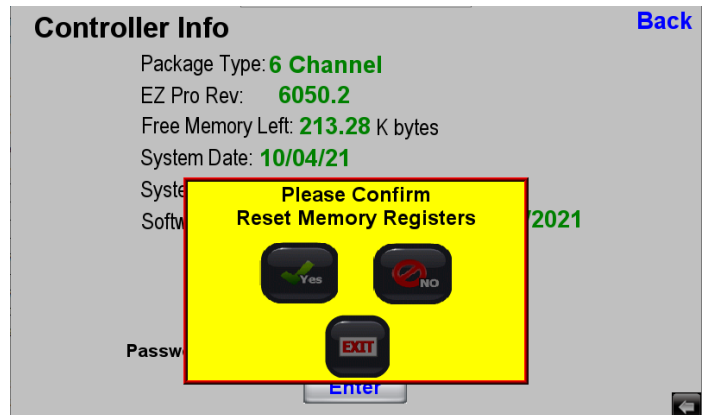

### "Trend Display" Menus

The last 1,000 records that are datalogged are stored in the system RAM and can be visualized in the trend display. Since datalogging occurs every 30 seconds for the process values and temperature from each connected sensor this equates to slightly more than the last 8 hours of trending is available for each channel. Of course all is automatically logged in permanent manner onto the integral USB flash drive and can be downloaded remotely via FTP as desired. Selecting the desired channel will load the trend display graph that is appropriate for the sensor type.

In the six (6) channel touchscreen controller used for these screenshots channel #1 is pH, channel #2 is standard/high range conductivity (EC), channel #3 is ultralow range conductivity (EC), channel #4 is dissolved oxygen (D.O.) and channel #5 is ion selective (ISE) while channel #6 is ORP (not shown). These five representative trend graphs shown below illustrate what typically loads for each sensor type.

It is possible to rewind and fast forward the graph to anywhere in the last 8 hour period. At any sampling point clicking on the graph will yield the exact process and temperature values at that moment. For the conductivity and dissolved oxygen type sensors the units for the pick a point feature will be in the unit selected at the time that the sensor was added.

Since values for these real-time on-screen trending graphs are stored in the RAM, they will disappear once the unit is powered down. Also since they are a rolling 8 hour period new values will replace older values once the 1,000 sample limit is reached.

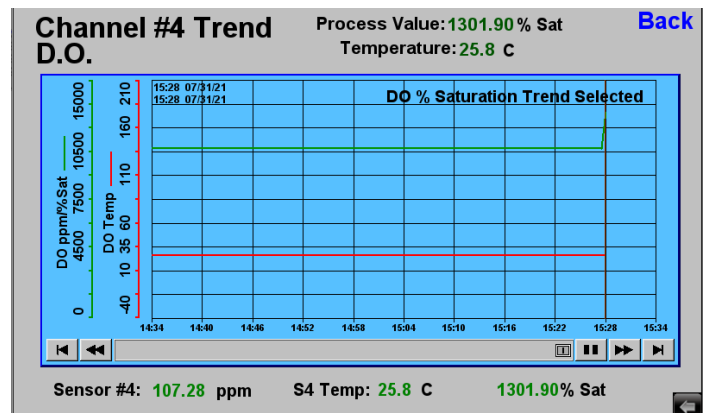
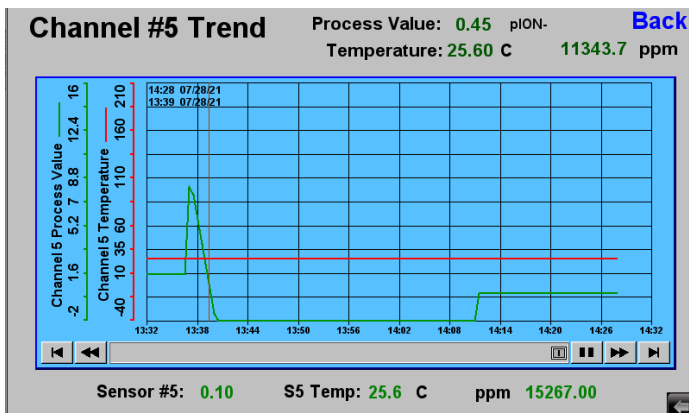
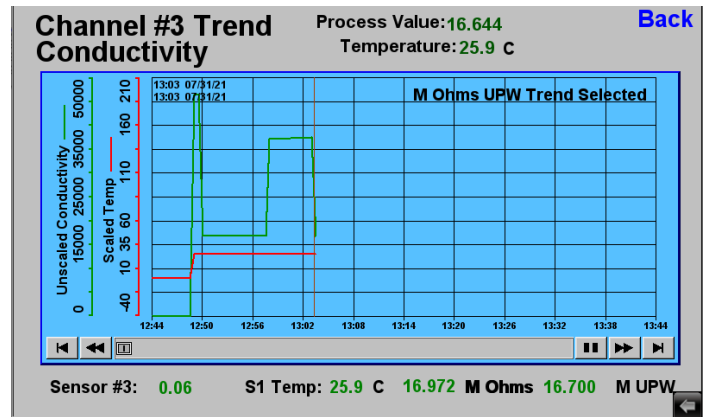
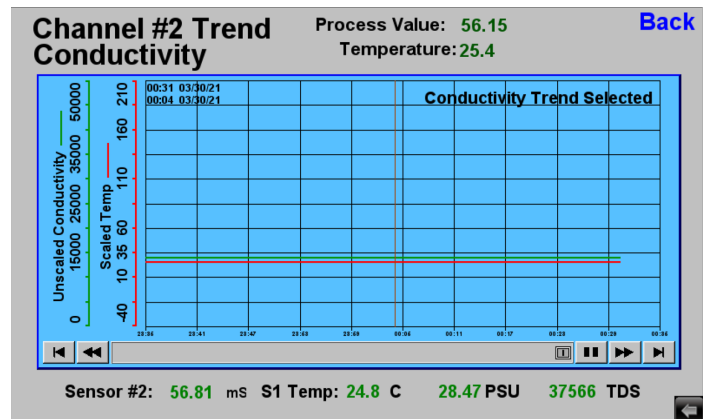
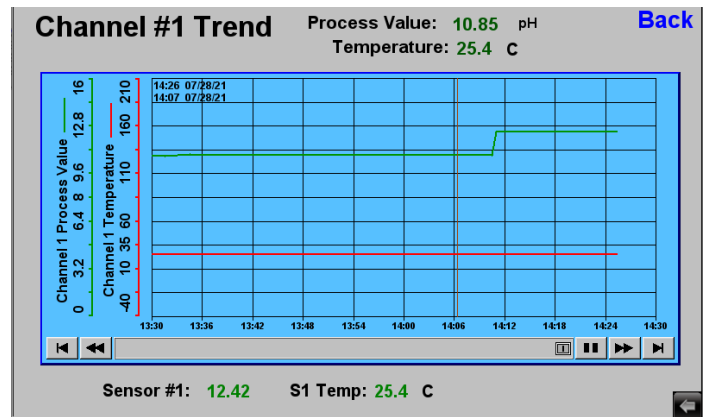

### “Hold Channel Output” Menu

Before performing any cleaning or re-calibration place the sensor for the channel in question on hold first. The default settings where no channels are on hold is shown to the right.

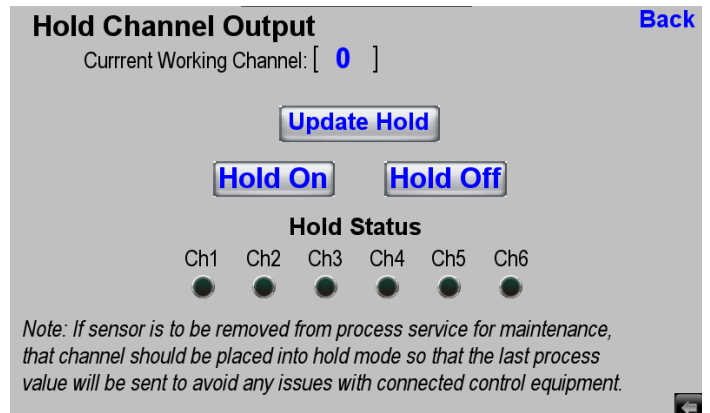

Select the channel of the sensor to be removed from service for cleaning and/or re-calibration.

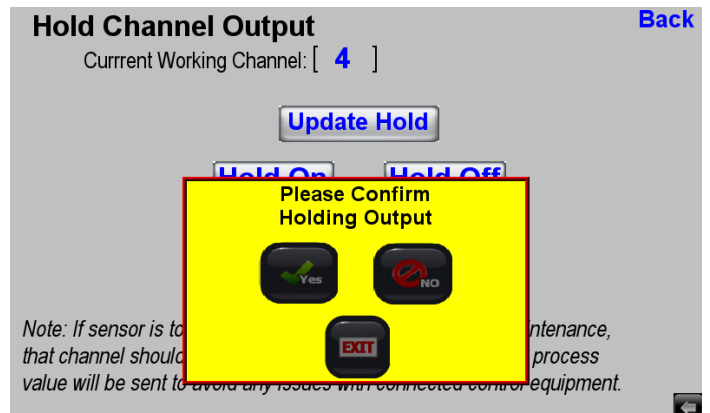

Place the selected channel on hold before removing from service for cleaning and/or recalibration.

After completing the cleaning and/or recalibration connect the sensor back into service and then take that channel off from hold.

In the example should to the right the sensors for channel #1 and #4 are currently out of service.

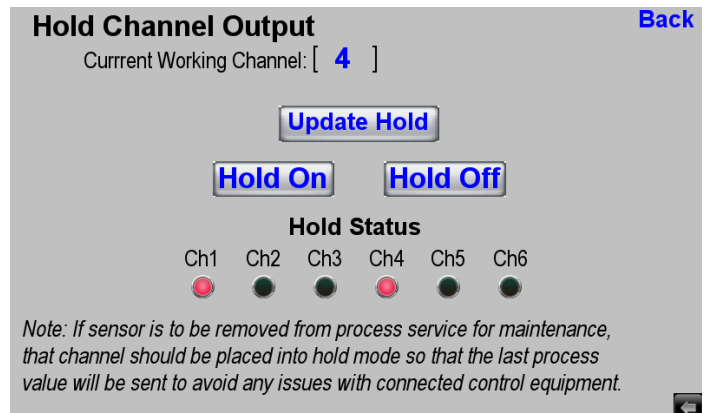

## “Analog Output Status” & “Configure Analog Output” Menus

The current process and output value for each analog output for each channel is shown based upon the current scaling setup. In addition the the type of sensor that is assigned for that channel and hold status is also displayed for each channel.

	Value	Sensor	Type	Output Value	Output Type
Ch1:	12.42	pH		18.20	mA
Ch2:	76.00	COND	ms	10.08	mA
Ch3:	0.06	COND	us	13.68	mA
Ch4:	7.82	D.O.	ppm	10.26	mA
Ch5:	15231.88	plON-	15231.88 ppm	13.75	mA
Ch6:	265.60	ORP		12.50	mA

To change the output type click on the “[Configure Analog Outputs Channel](#)” which will load the screen below. You must first choose the channel for which you wish make any changes to the analog output.

UNIT NOTE FOR DISSOLVED OXYGEN (DO) SENSORS:  
The units selected for the dissolved oxygen sensor at time channel is added to controller (ppm or % Saturation) will also be the units used for the analog outputs and relays.

UNIT NOTES FOR CONDUCTIVITY (EC) SENSORS:  
The units selected for the conductivity sensor at time channel is added to controller (mS/PSU/TDS for standard/high range and uS/MΩ/MΩ-UPW for the utlralow range) will also be the units used used for the analog outputs and relays. For conductivity units note whether you are operating in uS/cm or mS/cm when entering your analog outputs or relay setpoints.

From the “[Configure Analog Outputs Channel](#)” screen you can choose the output type as either voltage (0-10 VDC) or current (4-20mA).

**Configure Analog Output** Back

Select Working Channel: [ 1 ]

**Channel Type 2** Value Of 1 Equals 4-20mA  
Value Of 2 Equals 0-10vdc

Output To Configure For Six Channel Mode ( 1 - 6 )

Note: Only the analog output number corresponding to active channel is available for configuration.

When you click the “[Update Channel](#)” button you will be prompted to confirm the change with yellow dialog box. The change will take effect immediately once you exit this dialog box.

After choosing the output type for the given channel click “[Back](#)” to return to the “Analog Outputs Status” screen and then click on the “[Scale Analog Outputs](#)” and follow the instructions on following page to define the low and high septoints for the current working analog output channel and type.

**Configure Analog Output** Back

Select Working Channel: [ 1 ]

**Channel Type 2** Value Of 1 Equals 4-20mA  
Value Of 2 Equals 0-10vdc

Output ( 1 - 6 )

**Please Confirm Analog Output Change**

Note: Only the analog o is available for configuration.

### “Scale Analog Outputs” Menu

The current process value and low & high setpoints for each analog output for each channel is shown based upon the current scaling setup. Each low and high setpoint is individually adjustable. The values entered will not be loaded for the analog output channel until the “Update Scaling” button is clicked and confirmed. The sensor type is indicated below the channel number for ease of configuration to ensure that the proper scaling choices are used.

#### Dissolved Oxygen Scaling Notes:

There exists a toggle switch in the “Analog Output Status” screen that allows for selecting the units for the basis of the analog outputs to be either ppm or percent saturation (% Sat). The units displayed in yellow that indicate the current reading reflect the unit choice which is made in this screen.

#### Conductivity (EC) Sensor Scaling Note:

There exists three possible units for the conductivity sensors to serve as the basis of the analog output. For the **standard range mode** (scaling factor is 200 in sensor diagnostics screen) or **high range mode** (scaling factor is 2,000 in sensor diagnostics screen) there exists three choices which are made at the time that the sensor it added to the channel:

- Temperature Compensated Conductivity (uS or mS)
- Salinity (PSU)
- TDS (ppm)

For the ultralow range mode (scaling factor is 2 in the sensor diagnostics screen) there also exists three choices which are made at the time that the sensor it added to the channel:

- Temperature Compensated Conductivity (uS or mS)
- MegaOhms (MΩ) using standard ATC
- MegaOhms (MΩ) using special UPW ATC

Temperature conductivity can be in microSiemens units (indicated as uS) or else in milliSiemens units (indicated as mS). Look for unit designation next to the channel sensor type description. The value displayed in yellow is in the units shown above.

**See Appendix “G” for details about the various unit types available for the conductivity sensors.**

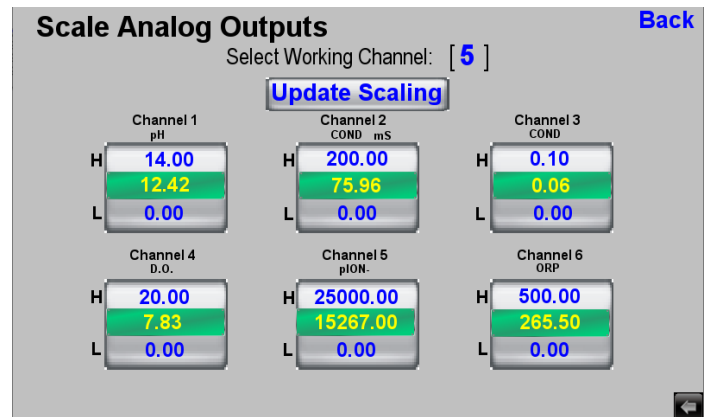

#### UNIT NOTE FOR DISSOLVED OXYGEN (DO) SENSORS:

The unit selected for the dissolved oxygen sensor at time channel is added to controller (ppm or % Saturation) will be the unit used for the analog output and relays.

#### UNIT NOTES FOR CONDUCTIVITY (EC) SENSORS:

The unit selected for the conductivity sensor at time channel is added to controller (mS/PSU/TDS for standard/high range and uS/MΩ/MΩ-UPW for the ultralow range) will be the unit used for the analog output and relays. For conductivity unit mode please note whether you are operating in uS/cm or mS/cm when entering your analog output or relay setpoints.

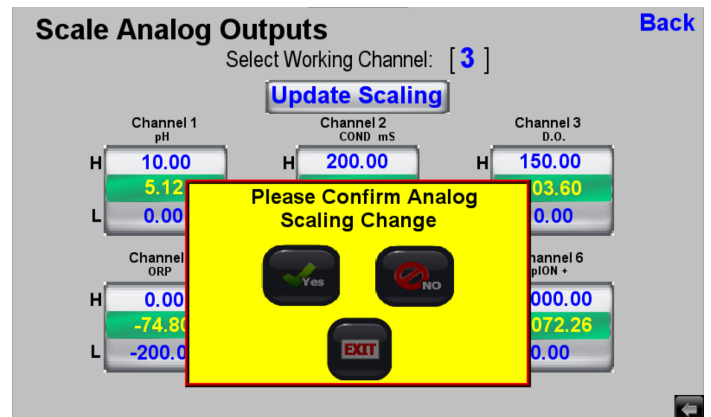

When you click the “Update Scaling” button you will be prompted to confirm the change with yellow dialog box. The change will take effect immediately once you exit this dialog box.

*“Wiring Details for Analog Outputs”*

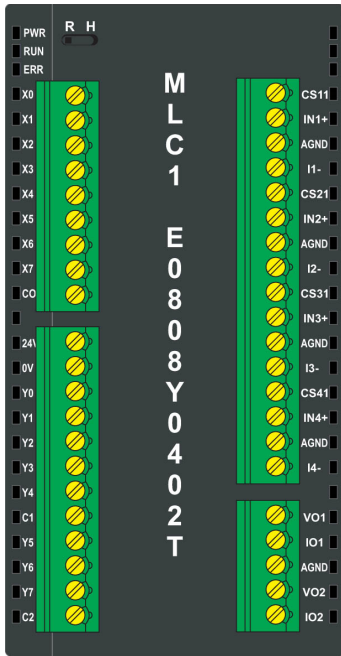

*Analog Outputs for Channels 1 & 2 on MLC1-E0808Y0402T*

Analog Outputs:

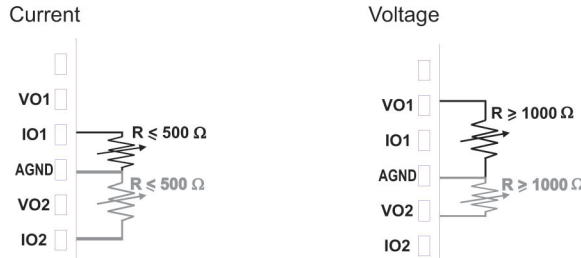

- Channel #1 → Voltage 0-10VDC Sent between AGND & V01
- Channel #1 → Current 4-20mA Sent between AGND & IO1
- Channel #2 → Voltage 0-10VDC Sent between AGND & V02
- Channel #2 → Current 4-20mA Sent between AGND & IO2

Voltage mode:

Current mode:

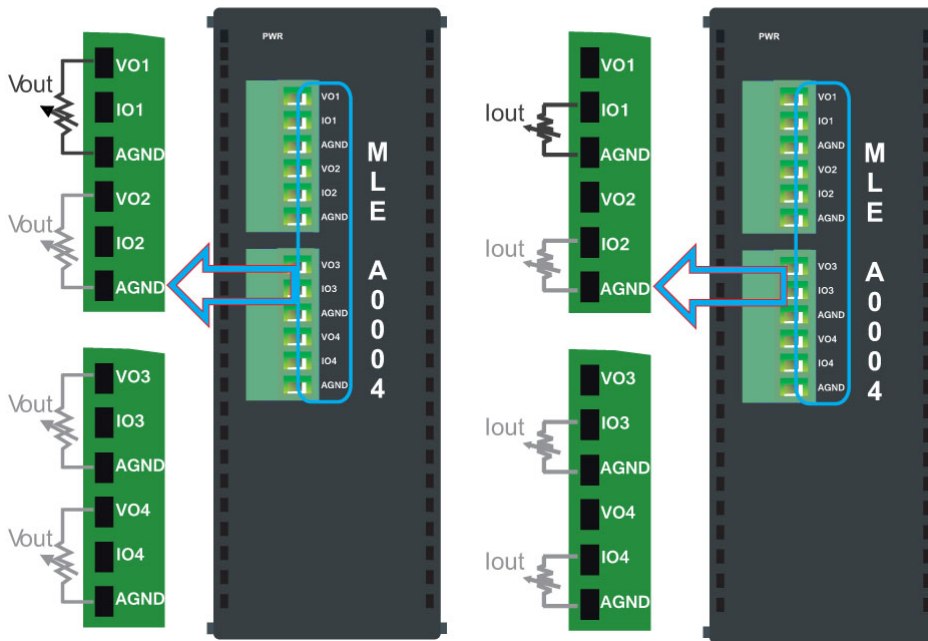

*Analog Outputs for Channels 3, 4, 5 & 6 on on MLE-A0004*

- Channel #3 → 0-10VDC Sent between AGND & V01
- Channel #3 → 4-20mA Sent between AGND & IO1
- Channel #4 → 0-10VDC Sent between AGND & V02
- Channel #4 → 4-20mA Sent between AGND & IO2
- Channel #5 → 0-10VDC Sent between AGND & V03
- Channel #5 → 4-20mA Sent between AGND & IO3
- Channel #6 → 0-10VDC Sent between AGND & V04
- Channel #6 → 4-20mA Sent between AGND & IO4

### *“Set Relay Output Limits” Menu*

The current process value for each channel is shown along with the current low and high setpoints. The top row shows the high “H” setpoint with a white background while the bottom shows the low “L” setpoint with a grey background. The current process value is shown in yellow on a green background. If the low or high alarm is active this is displayed in red below the high or low relay designation for the given channel.

To change the high or low scaling limit simply click on the value that you wish to change and enter the new value to be used.

For each relay there exists an adjustable delay time. The units for this delay time settings are 0.1 seconds. For the setting of 50 for the delay time this is 5.0 seconds. The time delay setting is the ONLY setting that is NOT stored in retentive memory. This means that it must be re-entered in the case that the unit is powered down. All other settings are maintained in the even of a power loss since they are stored in retentive register.

### *“Set Temperature Alarm Limits” Menu*

The current temperature value for each channel is shown along with the current low & high setpoints. The top row shows the high “H” setpoint with a white background while the bottom shows the low “L” setpoint with a grey background. The current temperature value is shown in yellow on a green background. If the low or high alarm is active this is displayed in red below the high or low relay designation for the given channel.

To change the high or low scaling limit simply click on the value that you wish to change and enter the new value to be used.

For each relay there exists an adjustable delay time. The units for this delay time settings are 0.1 seconds. For the setting of 50 for the delay time this is 5.0 seconds. The time delay setting is the one setting that is NOT stored in retentive memory. This means that it must be re-entered in the case that the unit is powered down. All other settings are maintained in the even of a power loss.

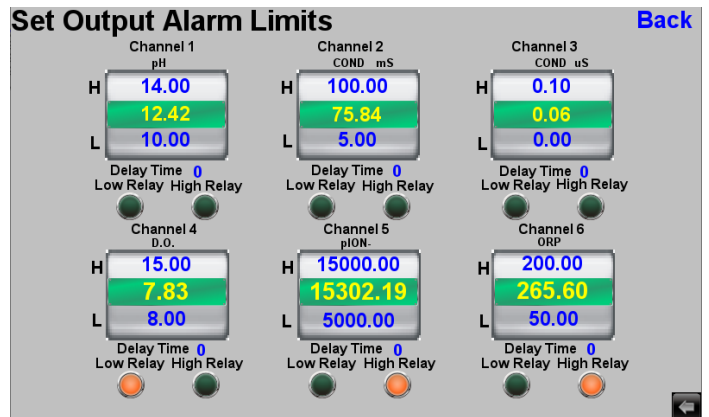

UNIT NOTE FOR DISSOLVED OXYGEN (DO) SENSORS:  
 The unit selected for the dissolved oxygen sensor at time channel is added to controller (ppm or % Saturation) will be the unit used for the analog output and relays.

UNIT NOTES FOR CONDUCTIVITY (EC) SENSORS:  
 The unit selected for the conductivity sensor at time channel is added to controller (mS/PSU/TDS for standard/high range and uS/MΩ/MΩ-UPW for the utlralow range) will be the unit used used for the analog output and relays. For conductivity unit mode please note whether you are operating in uS/cm or mS/cm when entering your analog output or relay setpoints.

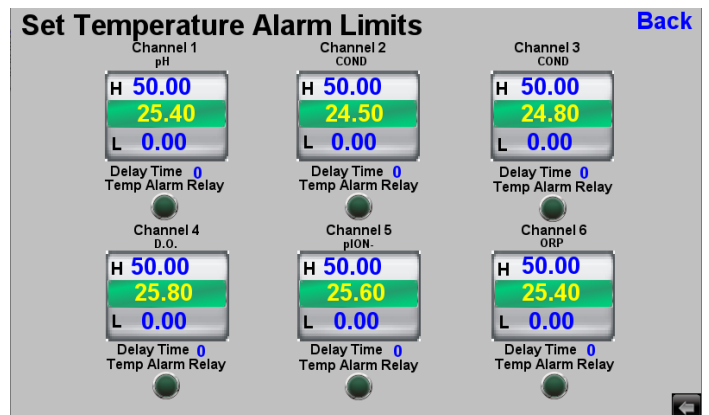



### “Wiring Details for Contact Relays”

MLE-D0016R:

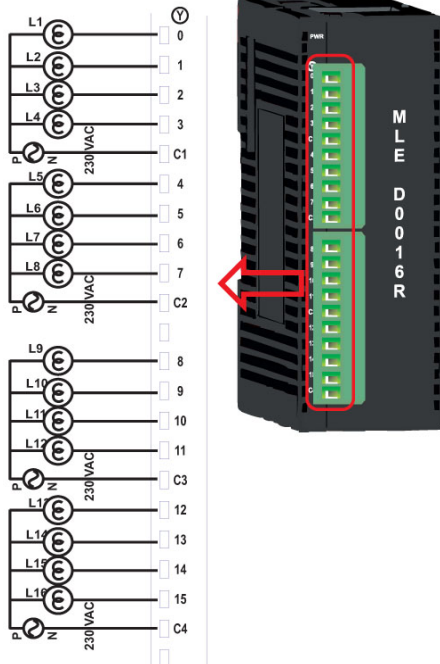

\*L1 to L16 are A.C. Load.

#### Contact Relays for **PROCESS** High & Low Setpoints for Channels 1, 2, 3, 4, 5 & 6 on MLE-D0016R

Channel #1 Low Setpoint → Between Terminal 0 & C1  
Channel #1 High Setpoint → Between Terminal 1 & C1

Channel #2 Low Setpoint → Between Terminal 2 & C1  
Channel #2 High Setpoint → Between Terminal 3 & C1

Channel #3 Low Setpoint → Between Terminal 4 & C2  
Channel #3 High Setpoint → Between Terminal 5 & C2

Channel #4 Low Setpoint → Between Terminal 6 & C2  
Channel #4 High Setpoint → Between Terminal 7 & C2

Channel #5 Low Setpoint → Between Terminal 8 & C3  
Channel #5 High Setpoint → Between Terminal 9 & C3

Channel #6 Low Setpoint → Between Terminal 10 & C3  
Channel #6 High Setpoint → Between Terminal 11 & C3

**ALWAYS ON POWER OUTAGE ALERT RELAY → Terminal 15 & C4**

*Relays between terminals 12 & C4, 13 & C4, 14 & C4, 15 & C4 are reserved for custom special order software configurations.*

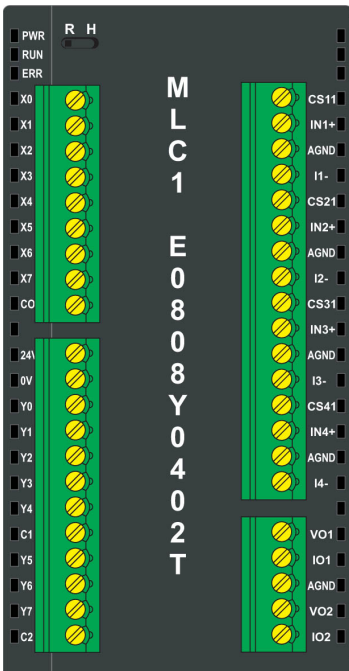

#### Contact Relays for **TEMPERATURE** High & Low Setpoints for Channels 1, 2, 3, 4, 5 & 6 on MLC1-E0808Y0402T

Channel #1 Low & High Setpoint → Between Terminal Y2 & C1

Channel #2 Low & High Setpoint → Between Terminal Y3 & C1

Channel #3 Low & High Setpoint → Between Terminal Y4 & C1

Channel #4 Low & High Setpoint → Between Terminal Y5 & C2

Channel #5 Low & High Setpoint → Between Terminal Y6 & C2

Channel #6 Low & High Setpoint → Between Terminal Y7 & C2

Sensor Type	Name of Value	Node	Integer Range	Sensor Register	Maple Register	Engineered Values
<b>Channel # 1</b>						
1	pH	1	0-18,000	30001	310700	-2.00 to +16.00
2	ORP	2	0-20,000	30001	310700	-1,000 to +1,000
3	Wide ORP	3	0-20,000	30001	310700	-2,000 to +2,000
4	Dissolved Oxygen ppm	4	0-15,000	30001	310700	0.00 to 150.00
5	Ion Selective pION	5	0-18,000	30001	310700	-2.000 to +16.000
6,7	Conductivity	6	0-50,000	30001	310700	Per Cell & Range Mode
1,2,3,4,5,6 & 7	°C	1,2,3,4,5,6	0-2,500	30002	310701	-40.0 to +210.0
1,2,5	Raw mV pH/ORP/ISE *	1,2,5	5,000-45,000	30003	310702	-1,000 to +1,000
3	Raw mV Wide ORP *	3	5,000-45,000	30003	310702	-2,000 to +2,000
4	Raw mV Dissolved Oxygen	4	0-25,000	30003	310702	0.00 to 250.00
6,7	Raw Conductivity	6	0-50,000	30003	310702	Per Cell & Range Mode
1,2,3,4,5,6 & 7	Raw °C **	1,2,3,4,5,6	0-2,500	30004	310703	-40.0 to +210.0
4	D.O. % Sat with Salinity	4	0-15,000	30005	310704	0.0 to 1,500.0
4	D.O. % Sat w/o Salinity	4	0-15,000	30006	310705	0.0 to 1,500.0
6	Salinity PSU	6	0-50,000	30005	310704	0.000 to 50.000
6	TDS ppm	6	0-50,000	30006	310705	0 to 100,000
7	MegaOhms	6	0-50,000	30005	310704	0.000 to 50.000
7	MegaOhms w/ UPW ATC	6	0-50,000	30006	310705	0.000 to 50.000
<b>Channel # 2</b>						
1	pH	41	0-18,000	30001	310710	-2.00 to +16.00
2	ORP	42	0-20,000	30001	310710	-1,000 to +1,000
3	Wide ORP	43	0-20,000	30001	310710	-2,000 to +2,000
4	Dissolved Oxygen ppm	44	0-15,000	30001	310710	0.00 to 150.00
5	Ion Selective pION	45	0-18,000	30001	310710	-2.000 to +16.000
6,7	Conductivity	46	0-50,000	30001	310710	Per Cell & Range Mode
1,2,3,4,5,6 & 7	°C	41,42,43,44,45,46	0-2,500	30002	310711	-40.0 to +210.0
1,2,5	Raw mV pH/ORP/ISE *	41,42,45	5,000-45,000	30003	310712	-1,000 to +1,000
3	Raw mV Wide ORP *	43	5,000-45,000	30003	310712	-2,000 to +2,000
4	Raw mV Dissolved Oxygen	44	0-25,000	30003	310712	0.00 to 250.00
6,7	Raw Conductivity	46	0-50,000	30003	310712	Per Cell & Range Mode
1,2,3,4,5,6 & 7	Raw °C **	41,42,43,44,45,46	0-2,500	30004	310713	-40.0 to +210.0
4	D.O. % Sat with Salinity	44	0-15,000	30005	310714	0.0 to 1,500.0
4	D.O. % Sat w/o Salinity	44	0-15,000	30006	310715	0.0 to 1,500.0
6	Salinity PSU	46	0-50,000	30005	310714	0.000 to 50.000
6	TDS ppm	46	0-50,000	30006	310715	0 to 100,000
7	MegaOhms	46	0-50,000	30005	310714	0.000 to 50.000
7	MegaOhms w/ UPW ATC	46	0-50,000	30006	310715	0.000 to 50.000

Sensor Type	Name of Value	Node	Integer Range	Sensor Register	Maple Register	Engineered Values
<b>Channel # 3</b>						
1	pH	81	0-18,000	30001	310720	-2.00 to +16.00
2	ORP	82	0-20,000	30001	310720	-1,000 to +1,000
3	Wide ORP	83	0-20,000	30001	310720	-2,000 to +2,000
4	Dissolved Oxygen ppm	84	0-15,000	30001	310720	0.00 to 150.00
5	Ion Selective pION	85	0-18,000	30001	310720	-2.000 to +16.000
6,7	Conductivity	86	0-50,000	30001	310720	Per Cell & Range Mode
1,2,3,4,5,6 & 7	°C	81,82,83,84,85,86	0-2,500	30002	310721	-40.0 to +210.0
1,2,5	Raw mV pH/ORP/ISE *	81,82,85	5,000-45,000	30003	310722	-1,000 to +1,000
3	Raw mV Wide ORP *	83	5,000-45,000	30003	310722	-2,000 to +2,000
4	Raw mV Dissolved Oxygen	84	0-25,000	30003	310722	0.00 to 250.00
6,7	Raw Conductivity	86	0-50,000	30003	310722	Per Cell & Range Mode
1,2,3,4,5,6 & 7	Raw °C **	81,82,83,84,85,86	0-2,500	30004	310723	-40.0 to +210.0
4	D.O. % Sat with Salinity	84	0-15,000	30005	310724	0.0 to 1,500.0
4	D.O. % Sat w/o Salinity	84	0-15,000	30006	310725	0.0 to 1,500.0
6	Salinity PSU	86	0-50,000	30005	310724	0.000 to 50.000
6	TDS ppm	86	0-50,000	30006	310725	0 to 100,000
7	MegaOhms	86	0-50,000	30005	310724	0.000 to 50.000
7	MegaOhms w/ UPW ATC	86	0-50,000	30006	310725	0.000 to 50.000
<b>Channel # 4</b>						
1	pH	121	0-18,000	30001	310730	-2.00 to +16.00
2	ORP	122	0-20,000	30001	310730	-1,000 to +1,000
3	Wide ORP	123	0-20,000	30001	310730	-2,000 to +2,000
4	Dissolved Oxygen ppm	124	0-15,000	30001	310730	0.00 to 150.00
5	Ion Selective pION	125	0-18,000	30001	310730	-2.000 to +16.000
6,7	Conductivity	126	0-50,000	30001	310730	Per Cell & Range Mode
1,2,3,4,5,6 & 7	°C	121,122,123,124,125,126	0-2,500	30002	310731	-40.0 to +210.0
1,2,5	Raw mV pH/ORP/ISE *	121,122,125	5,000-45,000	30003	310732	-1,000 to +1,000
3	Raw mV Wide ORP *	123	5,000-45,000	30003	310732	-2,000 to +2,000
4	Raw mV Dissolved Oxygen	124	0-25,000	30003	310732	0.00 to 250.00
6,7	Raw Conductivity	126	0-50,000	30003	310732	Per Cell & Range Mode
1,2,3,4,5,6 & 7	Raw °C **	121,122,123,124,125,126	0-2,500	30004	310733	-40.0 to +210.0
4	D.O. % Sat with Salinity	124	0-15,000	30005	310734	0.0 to 1,500.0
4	D.O. % Sat w/o Salinity	124	0-15,000	30006	310735	0.0 to 1,500.0
6	Salinity PSU	126	0-50,000	30005	310734	0.000 to 50.000
6	TDS ppm	126	0-50,000	30006	310735	0 to 100,000
7	MegaOhms	126	0-50,000	30005	310734	0.000 to 50.000
7	MegaOhms w/ UPW ATC	126	0-50,000	30006	310735	0.000 to 50.000

Sensor Type	Name of Value	Node	Integer Range	Sensor Register	Maple Register	Engineered Values
<b>Channel # 5</b>						
1	pH	161	0-18,000	30001	310740	-2.00 to +16.00
2	ORP	162	0-20,000	30001	310740	-1,000 to +1,000
3	Wide ORP	163	0-20,000	30001	310740	-2,000 to +2,000
4	Dissolved Oxygen ppm	164	0-15,000	30001	310740	0.00 to 150.00
5	Ion Selective pION	165	0-18,000	30001	310740	-2.000 to +16.000
6,7	Conductivity	166	0-50,000	30001	310740	Per Cell & Range Mode
1,2,3,4,5,6 & 7	°C	161,162,163,164,165,166	0-2,500	30002	310741	-40.0 to +210.0
1,2,5	Raw mV pH/ORP/ISE *	161,162,165	5,000-45,000	30003	310742	-1,000 to +1,000
3	Raw mV Wide ORP *	163	5,000-45,000	30003	310742	-2,000 to +2,000
4	Raw mV Dissolved Oxygen	164	0-25,000	30003	310742	0.00 to 250.00
6,7	Raw Conductivity	166	0-50,000	30003	310742	Per Cell & Range Mode
1,2,3,4,5,6 & 7	Raw °C **	161,162,163,164,165,166	0-2,500	30004	310743	-40.0 to +210.0
4	D.O. % Sat with Salinity	164	0-15,000	30005	310744	0.0 to 1,500.0
4	D.O. % Sat w/o Salinity	164	0-15,000	30006	310745	0.0 to 1,500.0
6	Salinity PSU	166	0-50,000	30005	310744	0.000 to 50.000
6	TDS ppm	166	0-50,000	30006	310745	0 to 100,000
7	MegaOhms	166	0-50,000	30005	310744	0.000 to 50.000
7	MegaOhms w/ UPW ATC	166	0-50,000	30006	310745	0.000 to 50.000
<b>Channel # 6</b>						
1	pH	201	0-18,000	30001	310750	-2.00 to +16.00
2	ORP	202	0-20,000	30001	310750	-1,000 to +1,000
3	Wide ORP	203	0-20,000	30001	310750	-2,000 to +2,000
4	Dissolved Oxygen ppm	204	0-15,000	30001	310750	0.00 to 150.00
5	Ion Selective pION	205	0-18,000	30001	310750	-2.000 to +16.000
6,7	Conductivity	206	0-50,000	30001	310750	Per Cell & Range Mode
1,2,3,4,5,6 & 7	°C	201,202,203,204,205,206	0-2,500	30002	310751	-40.0 to +210.0
1,2,5	Raw mV pH/ORP/ISE *	201,202,205	5,000-45,000	30003	310752	-1,000 to +1,000
3	Raw mV Wide ORP *	203	5,000-45,000	30003	310752	-2,000 to +2,000
4	Raw mV Dissolved Oxygen	204	0-25,000	30003	310752	0.00 to 250.00
6,7	Raw Conductivity	206	0-50,000	30003	310752	Per Cell & Range Mode
1,2,3,4,5,6 & 7	Raw °C **	201,202,203,204,205,206	0-2,500	30004	310753	-40.0 to +210.0
4	D.O. % Sat with Salinity	204	0-15,000	30005	310754	0.0 to 1,500.0
4	D.O. % Sat w/o Salinity	204	0-15,000	30006	310755	0.0 to 1,500.0
6	Salinity PSU	206	0-50,000	30005	310754	0.000 to 50.000
6	TDS ppm	206	0-50,000	30006	310755	0 to 100,000
7	MegaOhms	206	0-50,000	30005	310754	0.000 to 50.000
7	MegaOhms w/ UPW ATC	206	0-50,000	30006	310755	0.000 to 50.000

- \* When raw mV is below engineered value limit, then this is indicated by the integer 4,999 being sent for this index.*
- \* When raw mV is above engineered value limit, then this is indicated by the integer 45,001 being sent for this index.*
- \*\* When raw °C is above engineered value limit, then this is indicated by the integer 2,501 being sent for this index.*

Sensor Type	Name of Value	Node	Integer Range	Sensor Register	Maple Register	Engineered Values
<b>Channel # 1</b>						
1, 2, 3 or 5	Offset mV **	1,2,3,5	0-5,000	40001	310600	-250 to +250 mV
5	ISE mV Offset **	5	0-20,000	40001	310600	-1,000.00-1,000.00 mV
6	EC Offset Zero Dry in Air	6	0-1,000	40001	310600	0.00-2.00 %
1	Acid Slope *	1	600-1,800	40002	310601	30.0 to 90.0 mV/pH
4	DO Cell Slope *	4	70-600	40002	310601	0.70 to 6.00 mV/ppm
5	ISE Slope *	5	200-2,000	40002	310601	10.00-100.00 mV/pION
6,7	Slope for Ultralow & Standard EC	6	300-1,700	40002	310601	0.300 to 1.700 Gain
1	Base Slope ***	1	600-1,800	40003	310602	30.0 to 90.0 mV/pH
6	Slope for High Range Mode EC	6	300-1,700	40002	310602	0.300 to 1.700 Gain
1,2,3,4,5,6,7	Offset °C	1,2,3,4,5,6	0-500	40004	310603	-25.0 to +25.0 °C
1,2,3,5,6,7	Time since Offset mV or EC ZDA	1,2,3,4,5,6	0-65,535	40014	310604	Hours
1,4,5,6,7	Time since Acid/DO/ISE/EC Slope *	1,4,5,6	0-65,535	40015	310605	Hours
1,6	Time since Base pH / Hi EC Slope *	1,6	0-65,535	40016	310606	Hours
1,2,3,4,5,6,7	Time Since Offset °C	1,2,3,4,5,6	0-65,535	40017	310607	Hours
<b>Channel # 2</b>						
1, 2, 3 or 5	Offset mV **	41,42,43,45	0-5,000	40001	310610	-250 to +250 mV
5	ISE mV Offset **	45	0-20,000	40001	310610	-1,000.00-1,000.00 mV
6	EC Offset Zero Dry in Air	46	0-1,000	40001	310610	0.00-2.00 %
1	Acid Slope *	41	600-1,800	40002	310611	30.0 to 90.0 mV/pH
4	DO Cell Slope *	44	70-600	40002	310611	0.70 to 6.00 mV/ppm
5	ISE Slope *	45	200-2,000	40002	310611	10.00-100.00 mV/pION
6,7	Slope for Ultralow & Standard EC	46	300-1,700	40002	310611	0.300 to 1.700 Gain
1	Base Slope ***	41	600-1,800	40003	310612	30.0 to 90.0 mV/pH
6	Slope for High Range Mode EC	46	300-1,700	40002	310612	0.300 to 1.700 Gain
1,2,3,4,5,6,7	Offset °C	41,42,43,44,45,46	0-500	40004	310613	-25.0 to +25.0 °C
1,2,3,5,6,7	Time since Offset mV or EC ZDA	41,42,43,45,46	0-65,535	40014	310614	Hours
1,4,5,6,7	Time since Acid/DO/ISE/EC Slope *	41,44,45,46	0-65,535	40015	310605	Hours
1,6	Time since Base pH or High EC Slope *	41,46	0-65,535	40016	310606	Hours
1,2,3,4,5,6,7	Time Since Offset °C	41,42,43,44,45,46	0-65,535	40017	310607	Hours

Sensor Type	Name of Value	Node	Integer Range	Sensor Register	Maple Register	Engineered Values
<b>Channel # 3</b>						
1, 2, 3 or 5	Offset mV **	81,82,83,85	0-5,000	40001	310620	-250 to +250 mV
5	ISE mV Offset **	85	0-20,000	40001	310620	-1,000.00-1,000.00 mV
6	EC Offset Zero Dry in Air	86	0-1,000	40001	310620	0.00-2.00 %
1	Acid Slope *	81	600-1,800	40002	310621	30.0 to 90.0 mV/pH
4	DO Cell Slope *	84	70-600	40002	310621	0.70 to 6.00 mV/ppm
5	ISE Slope *	85	200-2,000	40002	310621	10.00-100.00 mV/pION
6,7	Slope for Ultralow & Standard EC	86	300-1,700	40002	310621	0.300 to 1.700 Gain
1	Base Slope ***	81	600-1,800	40003	310622	30.0 to 90.0 mV/pH
6	Slope for High Range Mode EC	86	300-1,700	40002	310622	0.300 to 1.700 Gain
1,2,3,4,5,6,7	Offset °C	81,82,83,84,85,86	0-500	40004	310623	-25.0 to +25.0 °C
1,2,3,5,6,7	Time since Offset mV or EC ZDA	81,82,83,85,86	0-65,535	40014	310624	Hours
1,4,5,6,7	Time since Acid/DO/ISE/EC Slope *	81,84,85,86	0-65,535	40015	310625	Hours
1,6	Time since Base pH or High EC Slope *	81,86	0-65,535	40016	310626	Hours
1,2,3,4,5,6,7	Time Since Offset °C	81,82,83,84,85,86	0-65,535	40017	310627	Hours
<b>Channel # 4</b>						
1, 2, 3 or 5	Offset mV **	121,122,123,125	0-5,000	40001	310630	-250 to +250 mV
5	ISE mV Offset **	125	0-20,000	40001	310630	-1,000.00-1,000.00 mV
6	EC Offset Zero Dry in Air	126	0-1,000	40001	310630	0.00-2.00 %
1	Acid Slope *	121	600-1,800	40002	310631	30.0 to 90.0 mV/pH
4	DO Cell Slope *	124	70-600	40002	310631	0.70 to 6.00 mV/ppm
5	ISE Slope *	125	200-2,000	40002	310631	10.00-100.00 mV/pION
6,7	Slope for Ultralow & Standard EC	126	300-1,700	40002	310631	0.300 to 1.700 Gain
1	Base Slope ***	121	600-1,800	40003	310632	30.0 to 90.0 mV/pH
6	Slope for High Range Mode EC	126	300-1,700	40002	310632	0.300 to 1.700 Gain
1,2,3,4,5,6,7	Offset °C	121,122,123,124,125,126	0-500	40004	310633	-25.0 to +25.0 °C
1,2,3,5,6,7	Time since Offset mV or EC ZDA	121,122,123,125,126	0-65,535	40014	310634	Hours
1,4,5,6,7	Time since Acid/DO/ISE/EC Slope *	121,124,125,126	0-65,535	40015	310635	Hours
1,6	Time since Base pH or High EC Slope *	121,126	0-65,535	40016	310636	Hours
1,2,3,4,5,6,7	Time Since Offset °C	121,122,123,124,125,126	0-65,535	40017	310637	Hours

Sensor Type	Name of Value	Node	Integer Range	Sensor Register	Maple Register	Engineered Values
<b>Channel # 5</b>						
1, 2, 3 or 5	Offset mV **	161,162,163,165	0-5,000	40001	310640	-250 to +250 mV
5	ISE mV Offset **	165	0-20,000	40001	310640	-1,000.00-1,000.00 mV
6	EC Offset Zero Dry in Air	166	0-1,000	40001	310640	0.00-2.00 %
1	Acid Slope *	161	600-1,800	40002	310641	30.0 to 90.0 mV/pH
4	DO Cell Slope *	164	70-600	40002	310641	0.70 to 6.00 mV/ppm
5	ISE Slope *	165	200-2,000	40002	310641	10.00-100.00 mV/pION
6,7	Slope for Ultralow & Standard EC	166	300-1,700	40002	310641	0.300 to 1.700 Gain
1	Base Slope ***	161	600-1,800	40003	310642	30.0 to 90.0 mV/pH
6	Slope for High Range Mode EC	166	300-1,700	40002	310642	0.300 to 1.700 Gain
1,2,3,4,5,6,7	Offset °C	161,162,163,164,165,166	0-500	40004	310643	-25.0 to +25.0 °C
1,2,3,5,6,7	Time since Offset mV or EC ZDA	161,162,163,165,166	0-65,535	40014	310644	Hours
1,4,5,6,7	Time since Acid/DO/ISE/EC Slope *	161,164,165,166	0-65,535	40015	310645	Hours
1,6	Time since Base pH or High EC Slope *	161,166	0-65,535	40016	310646	Hours
1,2,3,4,5,6,7	Time Since Offset °C	161,162,163,164,165,166	0-65,535	40017	310647	Hours
<b>Channel # 6</b>						
1, 2, 3 or 5	Offset mV **	201,202,203,205	0-5,000	40001	310650	-250 to +250 mV
5	ISE mV Offset **	205	0-20,000	40001	310650	-1,000.00-1,000.00 mV
6	EC Offset Zero Dry in Air	206	0-1,000	40001	310650	0.00-2.00 %
1	Acid Slope *	201	600-1,800	40002	310651	30.0 to 90.0 mV/pH
4	DO Cell Slope *	204	70-600	40002	310651	0.70 to 6.00 mV/ppm
5	ISE Slope *	205	200-2,000	40002	310651	10.00-100.00 mV/pION
6,7	Slope for Ultralow & Standard EC	206	300-1,700	40002	310651	0.300 to 1.700 Gain
1	Base Slope ***	201	600-1,800	40003	310652	30.0 to 90.0 mV/pH
6	Slope for High Range Mode EC	206	300-1,700	40002	310652	0.300 to 1.700 Gain
1,2,3,4,5,6,7	Offset °C	201,202,203,204,205,206	0-500	40004	310653	-25.0 to +25.0 °C
1,2,3,5,6,7	Time since Offset mV or EC ZDA	201,202,203,205,206	0-65,535	40014	310654	Hours
1,4,5,6,7	Time since Acid/DO/ISE/EC Slope *	201,204,205,206	0-65,535	40015	310655	Hours
1,6	Time since Base pH or High EC Slope *	201,206	0-65,535	40016	310656	Hours
1,2,3,4,5,6,7	Time Since Offset °C	201,202,203,204,205,206	0-65,535	40017	310657	Hours

\* Not applicable when sensor type is ORP

\*\* Not applicable when sensor type is Dissolved Oxygen (D.O.)

\*\*\* Not applicable when sensor type is Dissolved Oxygen (D.O.), ISE or ORP



Sensor Type	Name of Value	Node	Integer Range	Sensor Register	Maple Register	Engineered Values
<b>Channel # 1</b>						
1,2,3,4,5,6 & 7	Dampener (Averaging)	1,2,3,4,5,6	0-10	40007	310500	See Below *
1,2,3,4,5,6 & 7	Year of Manufacture	1,2,3,4,5,6	00-99	40024	310501	2000 to 2099
1,2,3,4,5,6 & 7	Month of Manufacture	1,2,3,4,5,6	1-12	40025	310502	1=Jan...12=Dec
1,2,3,4,5,6 & 7	Serial Number Letter	1,2,3,4,5,6	0-246	40026	310503	See Alpha Serial Chart
1,2,3,4,5,6 & 7	Serial Number #	1,2,3,4,5,6	000-255	40027	310504	Identifier in Alpha Block
1,2,3,4,5,6 & 7	Sensor Item Number	1,2,3,4,5,6	0-65,535	40028	310505	Unique Sensor Config
1,2,3,4,5,6 & 7	Min Temp in Use	1,2,3,4,5,6	0-2,500	40029	310506	-40 to +210.0 °C
1,2,3,4,5,6 & 7	Max Temp in Use	1,2,3,4,5,6	0-2,500	40030	310507	-40 to +210.0 °C
1,2,3,4,5,6 & 7	Total Time in Use	1,2,3,4,5,6	0-65,535	40031	310508	Hours
<b>Channel # 2</b>						
1,2,3,4,5,6 & 7	Dampener (Averaging)	41,42,43,44,45,46	0-10	40007	310510	See Below *
1,2,3,4,5,6 & 7	Year of Manufacture	41,42,43,44,45,46	00-99	40024	310511	2000 to 2099
1,2,3,4,5,6 & 7	Month of Manufacture	41,42,43,44,45,46	1-12	40025	310512	1=Jan...12=Dec
1,2,3,4,5,6 & 7	Serial Number Letter	41,42,43,44,45,46	0-246	40026	310513	See Alpha Serial Chart
1,2,3,4,5,6 & 7	Serial Number #	41,42,43,44,45,46	000-255	40027	310514	Identifier in Alpha Block
1,2,3,4,5,6 & 7	Sensor Item Number	41,42,43,44,45,46	0-65,535	40028	310515	Unique Sensor Config
1,2,3,4,5,6 & 7	Min Temp in Use	41,42,43,44,45,46	0-2,500	40029	310516	-40 to +210.0 °C
1,2,3,4,5,6 & 7	Max Temp in Use	41,42,43,44,45,46	0-2,500	40030	310517	-40 to +210.0 °C
1,2,3,4,5,6 & 7	Total Time in Use	41,42,43,44,45,46	0-65,535	40031	310518	Hours
<b>Channel # 3</b>						
1,2,3,4,5,6 & 7	Dampener (Averaging)	81,82,83,84,85,86	0-10	40007	310520	See Below *
1,2,3,4,5,6 & 7	Year of Manufacture	81,82,83,84,85,86	00-99	40024	310521	2000 to 2099
1,2,3,4,5,6 & 7	Month of Manufacture	81,82,83,84,85,86	1-12	40025	310522	1=Jan...12=Dec
1,2,3,4,5,6 & 7	Serial Number Letter	81,82,83,84,85,86	0-246	40026	310523	See Alpha Serial Chart
1,2,3,4,5,6 & 7	Serial Number #	81,82,83,84,85,86	000-255	40027	310524	Identifier in Alpha Block
1,2,3,4,5,6 & 7	Sensor Item Number	81,82,83,84,85,86	0-65,535	40028	310525	Unique Sensor Config
1,2,3,4,5,6 & 7	Min Temp in Use	81,82,83,84,85,86	0-2,500	40029	310526	-40 to +210.0 °C
1,2,3,4,5,6 & 7	Max Temp in Use	81,82,83,84,85,86	0-2,500	40030	310527	-40 to +210.0 °C
1,2,3,4,5,6 & 7	Total Time in Use	81,82,83,84,85,86	0-65,535	40031	310528	Hours

Sensor Type	Name of Value	Node	Integer Range	Sensor Register	Maple Register	Engineered Values
<b>Channel # 4</b>						
1,2,3,4,5,6 & 7	Dampener (Averaging)	121,122,123,124,125,126	0-10	40007	310530	See Below *
1,2,3,4,5,6 & 7	Year of Manufacture	121,122,123,124,125,126	00-99	40024	310531	2000 to 2099
1,2,3,4,5,6 & 7	Month of Manufacture	121,122,123,124,125,126	1-12	40025	310532	1=Jan...12=Dec
1,2,3,4,5,6 & 7	Serial Number Letter	121,122,123,124,125,126	0-246	40026	310533	See Alpha Serial Chart
1,2,3,4,5,6 & 7	Serial Number #	121,122,123,124,125,126	000-255	40027	310534	Identifier in Alpha Block
1,2,3,4,5,6 & 7	Sensor Item Number	121,122,123,124,125,126	0-65,535	40028	310535	Unique Sensor Config
1,2,3,4,5,6 & 7	Min Temp in Use	121,122,123,124,125,126	0-2,500	40029	310536	-40 to +210.0 °C
1,2,3,4,5,6 & 7	Max Temp in Use	121,122,123,124,125,126	0-2,500	40030	310537	-40 to +210.0 °C
1,2,3,4,5,6 & 7	Total Time in Use	121,122,123,124,125,126	0-65,535	40031	310538	Hours
<b>Channel # 5</b>						
1,2,3,4,5,6 & 7	Dampener (Averaging)	161,162,163,164,165,166	0-10	40007	310540	See Below *
1,2,3,4,5,6 & 7	Year of Manufacture	161,162,163,164,165,166	00-99	40024	310541	2000 to 2099
1,2,3,4,5,6 & 7	Month of Manufacture	161,162,163,164,165,166	1-12	40025	310542	1=Jan...12=Dec
1,2,3,4,5,6 & 7	Serial Number Letter	161,162,163,164,165,166	0-18	40026	310543	See Alpha Serial Chart
1,2,3,4,5,6 & 7	Serial Number #	161,162,163,164,165,166	000-255	40027	310544	Identifier in Alpha Block
1,2,3,4,5,6 & 7	Sensor Item Number	161,162,163,164,165,166	0-65,535	40028	310545	Unique Sensor Config
1,2,3,4,5,6 & 7	Min Temp in Use	161,162,163,164,165,166	0-2,500	40029	310546	-40 to +210.0 °C
1,2,3,4,5,6 & 7	Max Temp in Use	161,162,163,164,165,166	0-2,500	40030	310547	-40 to +210.0 °C
1,2,3,4,5,6 & 7	Total Time in Use	161,162,163,164,165,166	0-65,535	40031	310548	Hours
<b>Channel # 6</b>						
1,2,3,4,5,6 & 7	Dampener (Averaging)	201,202,203,204,205,206	0-10	40007	310550	See Below *
1,2,3,4,5,6 & 7	Year of Manufacture	201,202,203,204,205,206	00-99	40024	310551	2000 to 2099
1,2,3,4,5,6 & 7	Month of Manufacture	201,202,203,204,205,206	1-12	40025	310552	1=Jan...12=Dec
1,2,3,4,5,6 & 7	Serial Number Letter	201,202,203,204,205,206	0-246	40026	310553	See Alpha Serial Chart
1,2,3,4,5,6 & 7	Serial Number #	201,202,203,204,205,206	000-255	40027	310554	Identifier in Alpha Block
1,2,3,4,5,6 & 7	Sensor Item Number	201,202,203,204,205,206	0-65,535	40028	310555	Unique Sensor Config
1,2,3,4,5,6 & 7	Min Temp in Use	201,202,203,204,205,206	0-2,500	40029	310556	-40 to +210.0 °C
1,2,3,4,5,6 & 7	Max Temp in Use	201,202,203,204,205,206	0-2,500	40030	310557	-40 to +210.0 °C
1,2,3,4,5,6 & 7	Total Time in Use	201,202,203,204,205,206	0-65,535	40031	310558	Hours

\* 0=1, 1=2, 2=3, 3=4, 4=5, 5=8, 6=10, 7=15, 8=20, 9=30 Where Units are Seconds

Note for Serial Number: Complete serial is the follow string of indexes <40024>.<40025>.<40026>.<40027>

## APPENDIX 3 FOR REGISTER 40026

A	0	bA	38	dA	76	FA	114	HA	152	JA	190	nA	228
b	1	bb	39	db	77	Fb	115	Hb	153	Jb	191	nb	229
C	2	bC	40	dC	78	FC	116	HC	154	JC	192	nC	230
d	3	bd	41	dd	79	Fd	117	Hd	155	Jd	193	nd	231
E	4	bE	42	dE	80	FE	118	HE	156	JE	194	nE	232
F	5	bF	43	dF	81	FF	119	HF	157	JF	195	nF	233
g	6	bg	44	dg	82	Fg	120	Hg	158	Jg	196	ng	234
H	7	bH	45	dH	83	FH	121	HH	159	JH	197	nH	235
i	8	bi	46	di	84	Fi	122	Hi	160	Ji	198	ni	236
J	9	bj	47	dJ	85	FJ	123	HJ	161	JJ	199	nJ	237
L	10	bL	48	dL	86	FL	124	HL	162	JL	200	nL	238
n	11	bn	49	dn	87	Fn	125	Hn	163	Jn	201	nn	239
o	12	bo	50	do	88	Fo	126	Ho	164	Jo	202	no	240
P	13	bP	51	dP	89	FP	127	HP	165	JP	203	nP	241
r	14	br	52	dr	90	Fr	128	Hr	166	Jr	204	nr	242
S	15	bS	53	dS	91	FS	129	HS	167	JS	205	nS	243
t	16	bt	54	dt	92	Ft	130	Ht	168	Jt	206	nt	244
U	17	bU	55	dU	93	FU	131	HU	169	JU	207	nU	245
Y	18	bY	56	dY	94	FY	132	HY	170	JY	208	nY	246
AA	19	CA	57	EA	95	gA	133	iA	171	LA	209		
Ab	20	Cb	58	Eb	96	gb	134	ib	172	Lb	210		
AC	21	CC	59	EC	97	gC	135	iC	173	LC	211		
Ad	22	Cd	60	Ed	98	gd	136	id	174	Ld	212		
AE	23	CE	61	EE	99	gE	137	iE	175	LE	213		
AF	24	CF	62	EF	100	gF	138	iF	176	LF	214		
Ag	25	Cg	63	Eg	101	gg	139	ig	177	Lg	215		
AH	26	CH	64	EH	102	gH	140	iH	178	LH	216		
Ai	27	Ci	65	Ei	103	gi	141	ii	179	Li	217		
AJ	28	CJ	66	EJ	104	gJ	142	iJ	180	LJ	218		
AL	29	CL	67	EL	105	gL	143	iL	181	LL	219		
An	30	Cn	68	En	106	gn	144	in	182	Ln	220		
Ao	31	Co	69	Eo	107	go	145	io	183	Lo	221		
AP	32	CP	70	EP	108	gP	146	iP	184	LP	222		
Ar	33	Cr	71	Er	109	gr	147	ir	185	Lr	223		
AS	34	CS	72	ES	110	gS	148	iS	186	LS	224		
At	35	Ct	73	Et	111	gt	149	it	187	Lt	225		
AU	36	CU	74	EU	112	gU	150	iU	188	LU	226		
AY	37	CY	75	EY	113	gY	151	iY	189	LY	227		

### “Relay Log File” Menu

When a relay is turned off or on this event is recorded and can be viewed in this “Relay Event Status” table for archival purposes. In addition selected non alarm relay events are also recorded in this same log file such as loss of communications for a particular channel.

An email will be sent to the user defined distribution list each time that an event is recorded in the log.

The new alarm events can be acknowledged from this screen with the time of acknowledgement recorded. The event will be scrolled across the top of the home screen until it is acknowledged.

Events that are acknowledged but still active will be shown in yellow. Once the alarm condition is no longer present then it will switch to green.

[Back](#)

Date	Time	Event Type	Ack. Time	
07/11/19	13:40	Ch6 High Event	13:46	3
07/11/19	13:45	Ch5 Low Event	13:46	2
07/11/19	13:45	Ch5 High Event	13:46	3
07/11/19	14:02	Channel #2 has lost		4
07/11/19	14:02	Channel #2 has lost		5
07/11/19	14:03	Channel #2 has lost		6
07/11/19	15:18	Channel #1 has lost		3
07/12/19	08:26	Ch1 Low Event		9
07/12/19	10:22	Ch3 High Event		10
07/12/19	10:22	Ch5 Low Event		3

[Acknowledge Alarm](#)

[Back](#)

Date	Time	Event Type	Ack. Time	
07/11/19	13:40	Ch6 High Event	13:46	3
07/11/19	13:45	Ch5 Low Event	13:46	2
07/11/19	13:45	Ch5 High Event	13:46	3
07/11/19	14:02	Channel #2 has lost	10:26	4
07/11/19	14:02	Channel #2 has lost	10:26	5
07/11/19	14:03	Channel #2 has lost	10:26	6
07/11/19	15:18	Channel #1 has lost	10:26	3
07/12/19	08:26	Ch1 Low Event	10:26	9
07/12/19	10:22	Ch3 High Event	10:26	10
07/12/19	10:22	Ch5 Low Event	10:26	3

[Acknowledge Alarm](#)

[Back](#)

Date	Time	Event Type	Ack. Time	
07/11/19	13:40	Ch6 High Event	13:46	3
07/11/19	13:45	Ch5 Low Event	13:46	2
07/11/19	13:45	Ch5 High Event	13:46	3
07/11/19	14:02	Channel #2 has lost	10:26	4
07/11/19	14:02	Channel #2 has lost	10:26	5
07/11/19	14:03	Channel #2 has lost	10:26	6
07/11/19	15:18	Channel #1 has lost	10:26	3
07/12/19	08:26	Ch1 Low Event	10:26	9
07/12/19	10:22	Ch3 High Event	10:26	10
07/12/19	10:22	Ch5 Low Event	10:26	3

[Acknowledge Alarm](#)

## “Remote Access 2.0” Setup

Remote access capabilities are provided by the EZ Access 2.0 secure industrial platform from the Maple Systems Advanced HMI. In order to setup the EZ Access 2.0 feature the hardware key of the HMI need to be determined from the onscreen menu accessible from icon located at the bottom right of the screen. A password is required to accessed the onscreen features integral to the Maple Systems HMI. The default password is “111111” as shipped from the factory. This can and should be changed after the initial commissioning for good security practice.

Navigate to “Easy Access 2.0” tab to find hardware key (HWkey) required for Maple Systems activation card to register your device for remote access. **It may be necessary to hit “Refresh” button after entering valid Account & Password information.**

The EZ Access 2.0 tab on your system should look similar after following the steps that are detailed in the webpages linked below. You must create the EZAccess 2.0 domain and users before you can activate the HMI in question on screen.

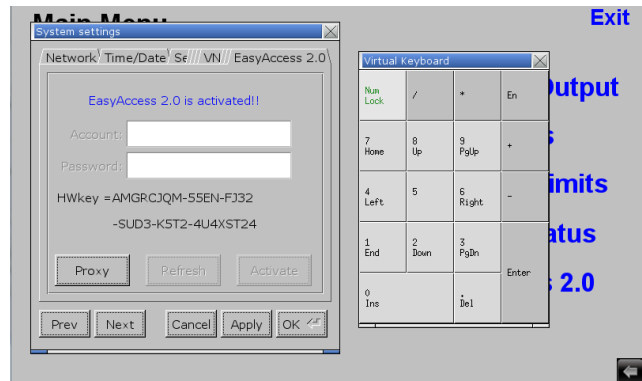
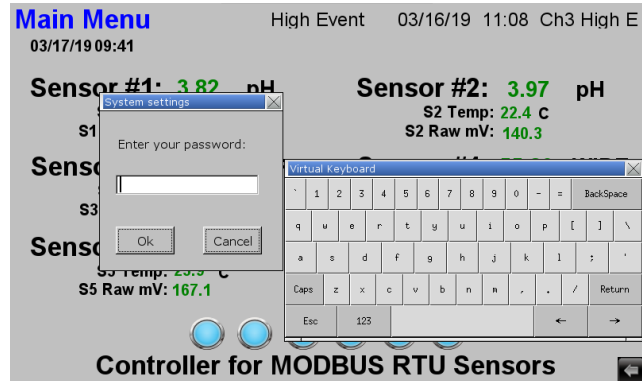

### INITIAL SETUP:

Follow Steps # 1 to 5 after the text “Activate units using an EasyAccess 2.0 Activation card (separate purchase). See Products tab for complete list” in the webpage linked below:

<https://www.maplesystems.com/iiot/easy-access-2.0/>

You will need to start either a single-connection or multi-connection VNC session from the system settings. Once this is successfully done your screen will look similar to the one shown to the right. **It is VERY strongly suggested to use a completely different password for VNC login than the local password used to access the system settings. This allows for a two-tiered access scheme were remote users can only alter system settings if provided with the additional different local password.**

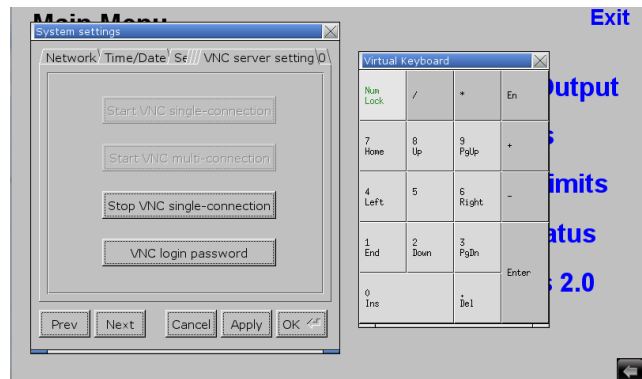

Finally you will need to start the EZAccess 2.0 service from the EasyAccess 2.0 screen on the controller. This screen in an active running state is shown to the right. Your screen should look similar if your setup has been successfully performed.

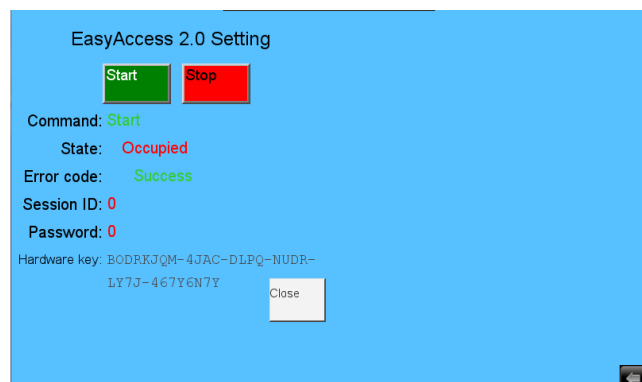

### “Remote Access 2.0” Remote Login

The core network information needs to be entered from the appropriate tab on the system settings (see right). This will ensure that there exists proper connectivity to activate and use the EZAccess installation for the given HMI as well as for the communications required for the MODBUS TCP slave features (see previous section for details on the register assignments for each sensor). The network used can be either public node or else be located on a subnet behind a firewall.

It is possible to remotely access the controller that has been properly setup for EZAccess 2.0 from a Windows PC, smartphone running iOS or Android as well as any tablets that are also running iOS or Android. This manual will focus on remote access from a Windows PC. Please install the apps on your smartphone or tablet and follow the provided instructions if you wish to access from one of these devices.

For your convenience the most current version of the EZAccess Setup & VNC Viewer for Windows at time of dispatch is provided on the USB flash drive connected to your HMI (see screenshot to the top on the right). Please install these two software on the Windows machine from which you wish to remotely access your controller and setup the path of the VNC viewer.

The most current version can be downloaded directly from Maple Systems and Real VNC websites:

- <https://www.maplesystems.com/SupportCenter/index.htm>
- <https://www.realvnc.com/en/connect/download/viewer/>

Each controller can be assigned an HMI name. This is what will appear when you login via the EZ Access Windows application and must choose the machine to which you will connect. In the example to the right the HMI in question has been named as “6 Channel HiQDT Controller”. For your field installation the most descriptive name is recommended for ease of deciding which machine you desire to remotely access.

Clicking on the appropriate icon will load the VNC session. Click on the VNC session and follow the onscreen instructions. The password to be entered is the one that is set from the onscreen menu with the default value being “111111”. The password for the local machine can be changed from the appropriate onscreen tab (see screenshot to right for visualization purposes).

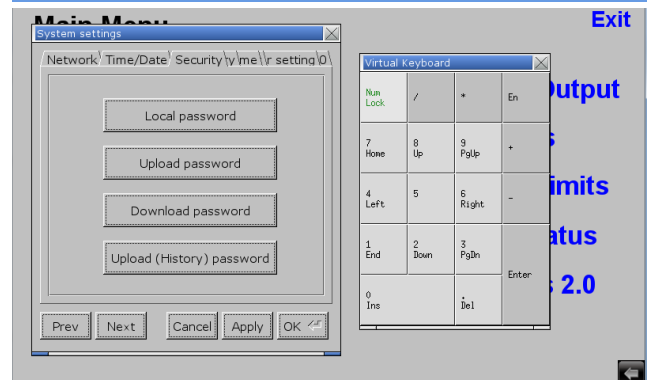
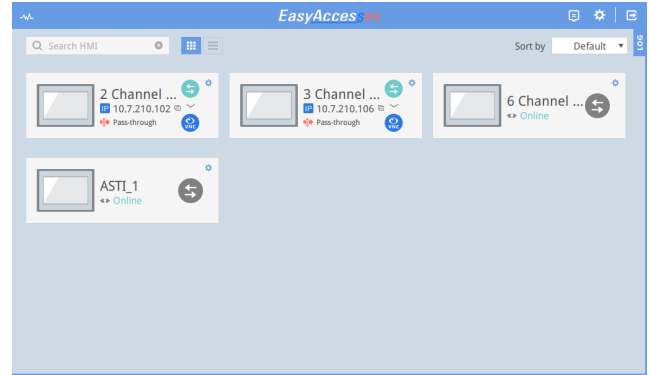
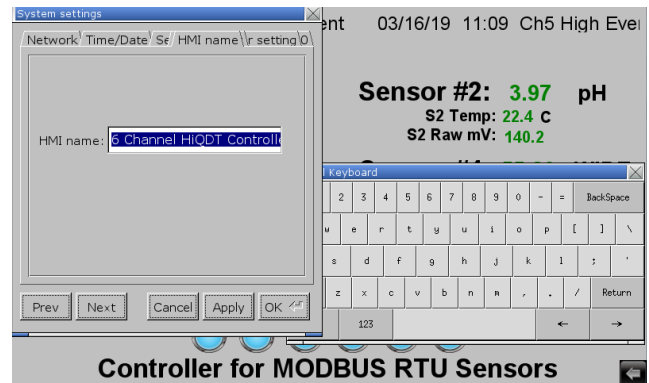
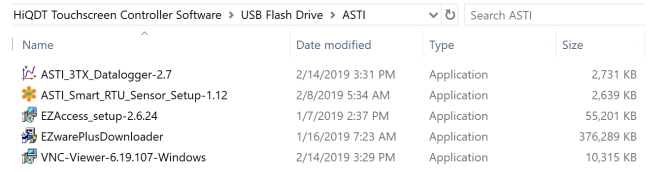
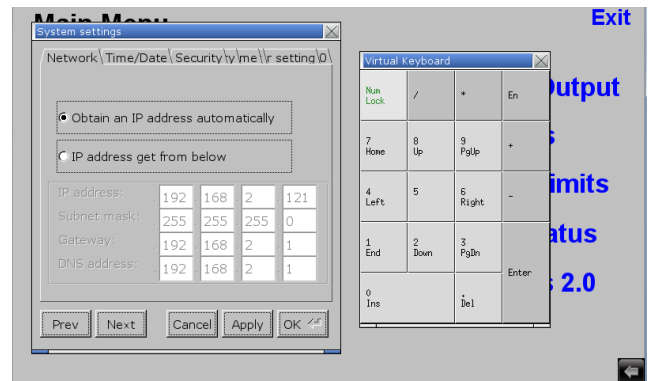

## Downloading & Viewing Logged Data from Controller – Part 1 of 2

Your controller automatically records the process values, temperature and raw mV input from each connected sensor that has been properly setup for an available channel every 30 seconds including a date stamp for each logged data set. In addition the sensor analytic information and calibrations are also recorded every 30 minutes for each channel. The sampling rates from the factory are set at the time the software is installed and cannot be changed later from the HMI in the field. If for some reason these default sampling rates are not suitable alternate sampling rates can be achieved on a special order software configuration basis (MOQ may apply for such special configuration orders).

The data that is logged must be converted from the “DTL” file format in the EZware Plus Downloaded software. This software is provided on the 32GB USB flash drive connected to the HMI5070 touchscreen of the controller. To the right is shown the typical software utilities that are provided at time of dispatch from the factory. It is recommended to copy them to a safe location to backup and archival purposes. Install the EZware Plus Downloader software.

Navigate to the Data Conversion tab in this software and click on the Easy Converter icon. This will load program as shown to the right.

Each individual DTL file that is created for each channel on a daily basis can be converted individually to the excel worksheet or else multiple days can be combined into file. Can example of converting the daily process values into a single file for channel one is shown to the right for visualization purposes as an example.

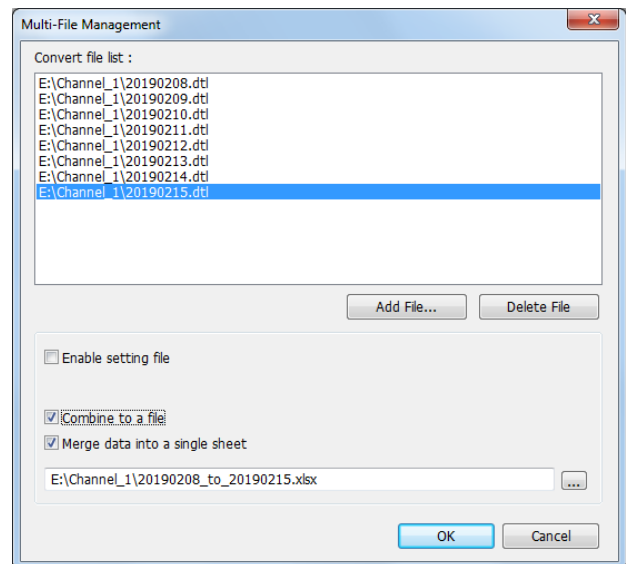
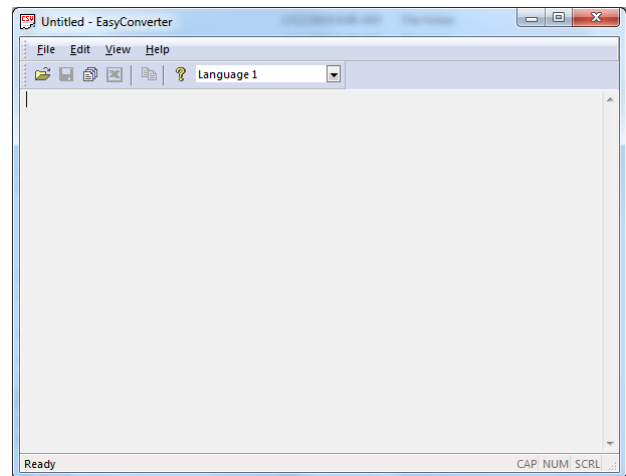
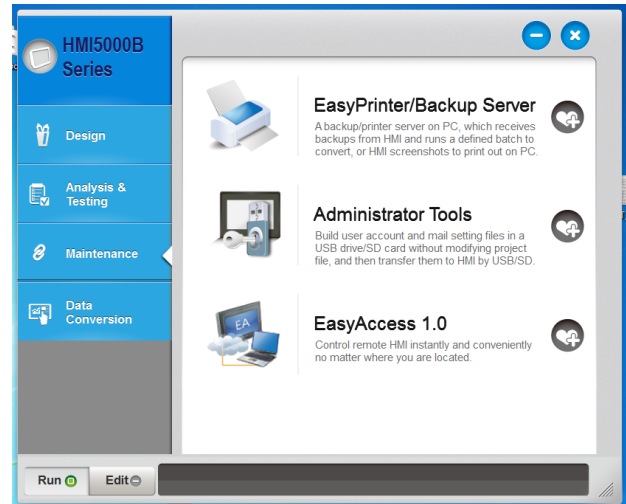

## Downloading & Viewing Logged Data from Controller - Part 2 of 2

An example of the window return the successful combining of multiple days of process value datalog files into a single excel file is shown to the right as an example for a multi-file batch conversion operation.

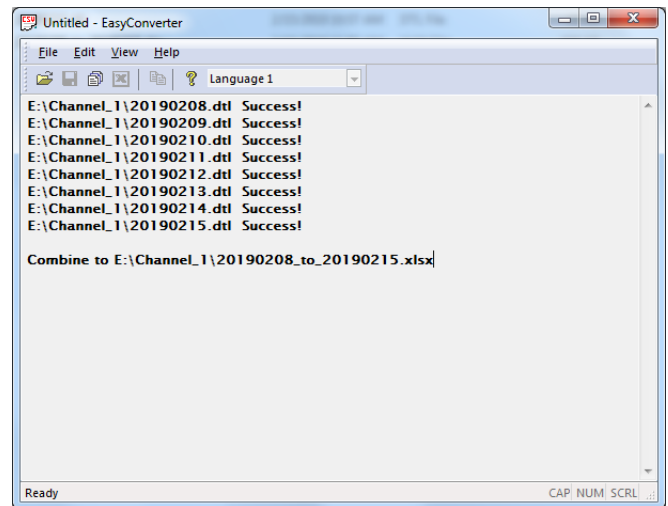

The folder directory for the USB flash drive in the controller is shown to the right. For each sensor channel that has been properly configured there will exist a channel directory to store the process values. A new DTL file with the date is created inside of the folder. For each sensor channel that has ever had a calibration performed there will exist a calibration directory for that channel. For each sensor channel that has ever had the sensor diagnostic information viewed there will exist a "Registers" directory. You will need to navigate to each folder separate and create either the individual or combined excel worksheet files for further workup and analysis. Since you will need to place this USB flash drive back into the controller for further datalogging it is recommended to copy such file to your local Windows machine as well as onto the USB flash drive.

Name	Date modified	Type
Channel_1	2/15/2019 12:00 AM	File folder
Channel_2	2/15/2019 12:00 AM	File folder
Channel_3	2/15/2019 12:00 AM	File folder
Channel_4	2/15/2019 12:00 AM	File folder
Channel_5	2/15/2019 12:00 AM	File folder
Channel_6	2/11/2019 1:52 PM	File folder
Sen1_Calibration	2/15/2019 12:21 AM	File folder
Sen1_Registers	2/15/2019 12:21 AM	File folder
Sen2_Calibration	2/15/2019 12:21 AM	File folder
Sen2_Registers	2/15/2019 12:21 AM	File folder
Sen3_Analytics	2/15/2019 12:21 AM	File folder
Sen3_Calibration	2/15/2019 12:21 AM	File folder
Sen4_Calibration	2/15/2019 12:21 AM	File folder
Sen5_Calibration	2/15/2019 12:21 AM	File folder
Sen6_Calibration	2/15/2019 12:21 AM	File folder
Sensor4_Analytic	2/15/2019 12:21 AM	File folder
Sensor5_Analytic	2/15/2019 12:21 AM	File folder
Sensor6_Analytic	2/15/2019 12:21 AM	File folder
MailData	2/15/2019 10:52 AM	File

On the following pages you will find examples of the exported Excel worksheets for the process values, sensor calibrations and analytic information for channel 1 for visualization purposes. The process values are exported in floating point engineered values as they have been converted on the controller from the raw unsigned integer values sent from the sensors. The sensor analytic and calibration information is exported in the raw unsigned integer values exactly as they are sent from the sensors. In order to convert them as may be required into a more intuitive engineered value you will need to use the RS-485 MODBUS RTU™ sensor implementation guide as the basis for making any such conversions.



## REMOTELY Downloading Logged Data from Touchscreen Controller

In addition to accessing logged data by removing the USB flash drive and following instructions on the previous pages the touchscreen controllers also allow for the logged data as detailed in the previous pages to be accessed remotely via FTP. This can be done on a local subnet, a public IP or securely behind a firewall using EZ Access 2.0. Instructions are below for how to access this logged data.

**Note that data cannot be deleted but rather only downloaded.**

Note 1: Determine the IP address of the HMI. You can find the IP address by opening the “System Information” window from the System Toolbar in HMI. For purposes of this instruction set we shall assume the HMI is on a local subnet with the IP address 192.168.1.50 although you will need to find the actual IP address of your machine. If using EZ Access 2.0 you will need to note the IP address that was dynamically assigned when you connect to the desired HMI and use that IP address.

Note 2: Make sure your computer is connected to the same local area network as the HMI.

Note 3: If connecting to HMI directly from Ethernet port on your computer, you must use an ethernet crossover cable. If going through an Ethernet switch, you can use a straight- thru or crossover cable.

From Windows Explorer or Web Browser:

1. Enter the following address, using the IP address of the HMI:  
ftp://uploadhis:111111@192.168.1.50
2. 111111 is the default “Upload history” password. If your password differs from the default please use the ACTUAL password set in your HMI. **It is STRONGLY recommended to change the upload history password from the default for best security practice.**
3. Press “Enter.” Click on “usbdisk” and then the actual USB flash drive present (typically “disk\_a\_1”)
4. Click on the folder names (Directory) to access the individual files. Click on a file to download it to your computer. With this remote access method files are downloaded individually.

In addition to downloading data from Windows Explorer or Web Browser it can also be accessed from any FTP client such as FileZilla (filezilla-project.org/). **Using an FTP client has the advantage of being able to download multiple files automated in batch.** The settings would be as follows:

Host:

192.168.1.50 (use ACTUAL IP address when logging in to your particular HMI)

Encryption:

None (Plain FTP)

User:

uploadhis

Password:

111111 (use your ACTUAL password if it differs from the default)



Date	Time	Channel 1 Process Value	Channel 1 Temperature	Channel 1 mV
2/8/19	14:32:26	4.13	23.5	141.3
2/8/19	14:34:11	4.11	23.5	142.8
2/8/19	14:34:41	4.12	23.5	144.2
2/8/19	14:35:11	4.12	23.5	142.0
2/8/19	14:36:06	4.13	23.5	140.6
2/8/19	14:36:36	4.14	23.5	140.6
2/8/19	14:37:06	4.12	23.5	141.3
2/8/19	14:37:36	4.13	23.5	140.3
2/8/19	14:38:06	4.13	23.5	140.7
2/8/19	14:38:36	4.13	23.5	140.5
2/8/19	14:39:06	4.12	23.5	143.8
2/8/19	14:39:36	4.13	23.5	140.9
2/8/19	14:40:06	4.12	23.5	144.2
2/8/19	14:40:36	4.14	23.5	140.3
2/8/19	14:41:06	4.12	23.5	144.8
2/8/19	14:41:36	4.12	23.5	141.9
2/8/19	14:42:06	4.13	23.5	140.5
2/8/19	14:42:36	4.13	23.5	140.8
2/8/19	14:43:06	4.11	23.5	144.7
2/8/19	14:43:36	4.13	23.5	140.2
2/8/19	14:44:06	4.12	23.5	143.9
2/8/19	14:44:36	4.12	23.5	144.5
2/8/19	14:45:06	4.13	23.5	143.3
2/8/19	14:45:36	4.11	23.5	144.3
2/8/19	14:46:06	4.13	23.5	140.4
2/8/19	14:46:36	4.13	23.5	142.6
2/8/19	14:47:06	4.13	23.5	140.3
2/8/19	14:47:36	4.12	23.5	142.0
2/8/19	14:48:06	4.12	23.5	144.3
2/8/19	14:48:36	4.12	23.5	143.1
2/8/19	14:49:06	4.12	23.5	143.5
2/8/19	14:49:36	4.13	23.5	140.3
2/8/19	14:50:06	4.13	23.5	141.2
2/8/19	14:50:36	4.12	23.5	144.2
2/8/19	14:51:06	4.13	23.5	142.7
2/8/19	14:51:36	4.13	23.5	141.5
2/8/19	14:52:06	4.12	23.5	144.8
2/8/19	14:52:36	4.12	23.5	144.7
2/8/19	14:53:06	4.13	23.5	140.3
2/8/19	14:53:36	4.13	23.5	140.3
2/8/19	14:54:06	4.13	23.5	141.4



Date	Time	pH_ORP Offset	Low_pH Slope	Hi_pH Slope	C Offset	Hours mV_Offset	Hours Low_Slope	Hours Hi_Slope	Hours C_Offset
2/8/19	15:05:36	2197	1208	1115	249	79	79	79	79
2/8/19	15:35:36	2197	1208	1115	249	79	79	79	79
2/8/19	16:05:36	2197	1208	1115	249	80	80	80	80
2/8/19	16:35:36	2197	1208	1115	249	80	80	80	80
2/8/19	17:05:36	2197	1208	1115	249	81	81	81	81
2/8/19	17:35:36	2197	1208	1115	249	81	81	81	81
2/8/19	18:05:36	2197	1208	1115	249	82	82	82	82
2/8/19	18:35:36	2197	1208	1115	249	82	82	82	82
2/8/19	19:05:36	2197	1208	1115	249	83	83	83	83
2/8/19	19:35:36	2197	1208	1115	249	83	83	83	83
2/8/19	20:05:36	2197	1208	1115	249	84	84	84	84
2/8/19	20:35:36	2197	1208	1115	249	84	84	84	84
2/8/19	21:05:36	2197	1208	1115	249	85	85	85	85
2/8/19	21:35:36	2197	1208	1115	249	85	85	85	85
2/8/19	22:05:36	2197	1208	1115	249	86	86	86	86
2/8/19	22:35:36	2197	1208	1115	249	86	86	86	86
2/8/19	23:05:36	2197	1208	1115	249	87	87	87	87
2/8/19	23:35:36	2197	1208	1115	249	87	87	87	87
2/9/19	0:05:36	2197	1208	1115	249	88	88	88	88
2/9/19	0:35:36	2197	1208	1115	249	88	88	88	88
2/9/19	1:05:36	2197	1208	1115	249	89	89	89	89
2/9/19	1:35:36	2197	1208	1115	249	89	89	89	89
2/9/19	2:05:36	2197	1208	1115	249	90	90	90	90
2/9/19	2:35:36	2197	1208	1115	249	90	90	90	90
2/9/19	3:05:36	2197	1208	1115	249	91	91	91	91
2/9/19	3:35:36	2197	1208	1115	249	91	91	91	91
2/9/19	4:05:36	2197	1208	1115	249	92	92	92	92
2/9/19	4:35:36	2197	1208	1115	249	92	92	92	92
2/9/19	5:05:36	2197	1208	1115	249	93	93	93	93
2/9/19	5:35:36	2197	1208	1115	249	93	93	93	93
2/9/19	6:05:36	2197	1208	1115	249	94	94	94	94
2/9/19	6:35:36	2197	1208	1115	249	94	94	94	94
2/9/19	7:05:36	2197	1208	1115	249	95	95	95	95
2/9/19	7:35:36	2197	1208	1115	249	95	95	95	95
2/9/19	8:05:36	2197	1208	1115	249	96	96	96	96
2/9/19	9:04:44	2197	1208	1115	249	97	97	97	97
2/9/19	9:34:44	2197	1208	1115	249	97	97	97	97
2/9/19	10:04:44	2197	1208	1115	249	97	97	97	97
2/9/19	10:34:44	2197	1208	1115	249	97	97	97	97
2/9/19	11:04:44	2197	1208	1115	249	98	98	98	98
2/9/19	11:34:44	2197	1208	1115	249	98	98	98	98
2/9/19	12:04:44	2197	1208	1115	249	99	99	99	99
2/9/19	12:34:44	2197	1208	1115	249	99	99	99	99



<b>Date</b>	<b>Time</b>	<b>Dampen</b>	<b>Year</b>	<b>Month</b>	<b>Serial Letter</b>	<b>Serial Number</b>	<b>Sensor Item #</b>	<b>Min Temp</b>	<b>Max Temp</b>	<b>Time In Service</b>
2/8/19	15:05:36	6	18	11	3	0	1418	591	705	570
2/8/19	15:35:36	6	18	11	3	0	1418	591	705	570
2/8/19	16:05:36	6	18	11	3	0	1418	591	705	571
2/8/19	16:35:36	6	18	11	3	0	1418	591	705	571
2/8/19	17:05:36	6	18	11	3	0	1418	591	705	572
2/8/19	17:35:36	6	18	11	3	0	1418	591	705	572
2/8/19	18:05:36	6	18	11	3	0	1418	591	705	573
2/8/19	18:35:36	6	18	11	3	0	1418	591	705	573
2/8/19	19:05:36	6	18	11	3	0	1418	591	705	574
2/8/19	19:35:36	6	18	11	3	0	1418	591	705	574
2/8/19	20:05:36	6	18	11	3	0	1418	591	705	575
2/8/19	20:35:36	6	18	11	3	0	1418	591	705	575
2/8/19	21:05:36	6	18	11	3	0	1418	591	705	576
2/8/19	21:35:36	6	18	11	3	0	1418	591	705	576
2/8/19	22:05:36	6	18	11	3	0	1418	591	705	577
2/8/19	22:35:36	6	18	11	3	0	1418	591	705	577
2/8/19	23:05:36	6	18	11	3	0	1418	591	705	578
2/8/19	23:35:36	6	18	11	3	0	1418	591	705	578
2/9/19	0:05:36	6	18	11	3	0	1418	591	705	579
2/9/19	0:35:36	6	18	11	3	0	1418	591	705	579
2/9/19	1:05:36	6	18	11	3	0	1418	591	705	580
2/9/19	1:35:36	6	18	11	3	0	1418	591	705	580
2/9/19	2:05:36	6	18	11	3	0	1418	591	705	581
2/9/19	2:35:36	6	18	11	3	0	1418	591	705	581
2/9/19	3:05:36	6	18	11	3	0	1418	591	705	582
2/9/19	3:35:36	6	18	11	3	0	1418	591	705	582
2/9/19	4:05:36	6	18	11	3	0	1418	591	705	583
2/9/19	4:35:36	6	18	11	3	0	1418	591	705	583
2/9/19	5:05:36	6	18	11	3	0	1418	591	705	584
2/9/19	5:35:36	6	18	11	3	0	1418	591	705	584
2/9/19	6:05:36	6	18	11	3	0	1418	591	705	585
2/9/19	6:35:36	6	18	11	3	0	1418	591	705	585
2/9/19	7:05:36	6	18	11	3	0	1418	591	705	586
2/9/19	7:35:36	6	18	11	3	0	1418	591	705	586
2/9/19	8:05:36	6	18	11	3	0	1418	591	705	587
2/9/19	9:04:44	6	18	11	3	0	1418	591	705	588
2/9/19	9:34:44	6	18	11	3	0	1418	591	705	588
2/9/19	10:04:44	6	18	11	3	0	1418	591	705	588
2/9/19	10:34:44	6	18	11	3	0	1418	591	705	588
2/9/19	11:04:44	6	18	11	3	0	1418	591	705	589
2/9/19	11:34:44	6	18	11	3	0	1418	591	705	589
2/9/19	12:04:44	6	18	11	3	0	1418	591	705	590
2/9/19	12:34:44	6	18	11	3	0	1418	591	705	590

**APPENDIX "A"**

***Temperature Considerations for Calibrating pH Sensors with pH Buffers – Part 1 of 2***

Exact pH Values of the NIST Traceable pH buffers at Various Temperatures  
Nominal pH Buffer Designation @ 25°C Shown in Gray at Top of Column

Temp °C	1.68	4.00	6.86	7.00	9.18	10.01	12.45
0	1.67	4.01	6.98	7.11	9.46	10.32	13.42
5	1.67	4.00	6.95	7.08	9.39	10.25	13.21
10	1.67	4.00	6.92	7.06	9.33	10.18	13.00
15	1.67	4.00	6.90	7.03	9.28	10.12	12.81
20	1.68	4.00	6.88	7.01	9.23	10.06	12.63
25	1.68	4.00	6.86	7.00	9.18	10.01	12.45
30	1.68	4.01	6.85	6.98	9.14	9.97	12.29
35	1.69	4.02	6.84	6.98	9.10	9.93	12.13
40	1.69	4.03	6.84	6.97	9.07	9.89	11.98
45	1.70	4.04	6.83	6.97	9.04	9.86	11.84
50	1.71	4.06	6.83	6.97	9.02	9.83	11.71
55	1.72	4.07	6.83	6.97	8.99	9.80	11.57
60	1.72	4.09	6.84	6.98	8.97	9.78	11.45

NIST traceable pH buffers are the most commonly used methods for calibration of pH sensors. On each pH buffer bottle is written the exact pH value of the buffer at variety of temperature conditions. Listed above are exact pH values for the most commonly used buffers between 0 and 60 °C. When using the ASTI HiQDT Touchscreen Controller for calibration of your IOTRON™ series Smart Digital HiQDT type RS-485 MODBUS RTU pH sensors use the autobuffer calibration mode if using the pH buffers detailed above. For any other pH buffers you will need to obtained the exact pH value for the current temperature condition. This information is typically provided on the label of the pH buffer.

**NOTE: ASTI HiQDT touchscreen controller software automatically corrects for temperature induced change to buffer to compute the exact pH value of buffer automatically when calibrations are performed with autobuffer calibration mode. Exact pH value of the buffer at the current temperature obtained from the connected HiQDT pH sensor is used for calibration. This may differ from the nominal value of the buffer at the reference 25 degree Celsius condition.**

To use any pH buffer besides 1.68, 4.00, 6.86, 7.00, 9.18, 10.01 or 12.45 you will need to account for the temperature induced shift of the pH value for the buffer in both the Windows software as well as any other devices used to perform calibrations of the HiQDT pH sensors. There are no reliable pH buffers below 1.69 and above 12.45 and so specialized and custom calibration schemes needed to be used for these situations. Contact factory for assistance in such cases.

Inquire to the factory if you plan to measure consistently below pH=1.0 or above pH=13.0 for special assistance. As can be seen from mere inspection the temperature dependence of high pH buffers is much more significant than for low pH buffers. Similarly for process solutions with high pH the temperature induced pH dependence may be quite significant and should be considered when trying to control such systems with fluctuating temperature. Process solutions with relatively weak ionic strength (low conductivity) are also rather prone to higher temperature induced pH shifts whereas process solution with relativley high ionic strength (high conductivity) are less prone to temperature induced pH shifts.

**APPENDIX "B"**

**Temperature Considerations for Calibrating pH Sensors with pH Buffers – Part 2 of 2**

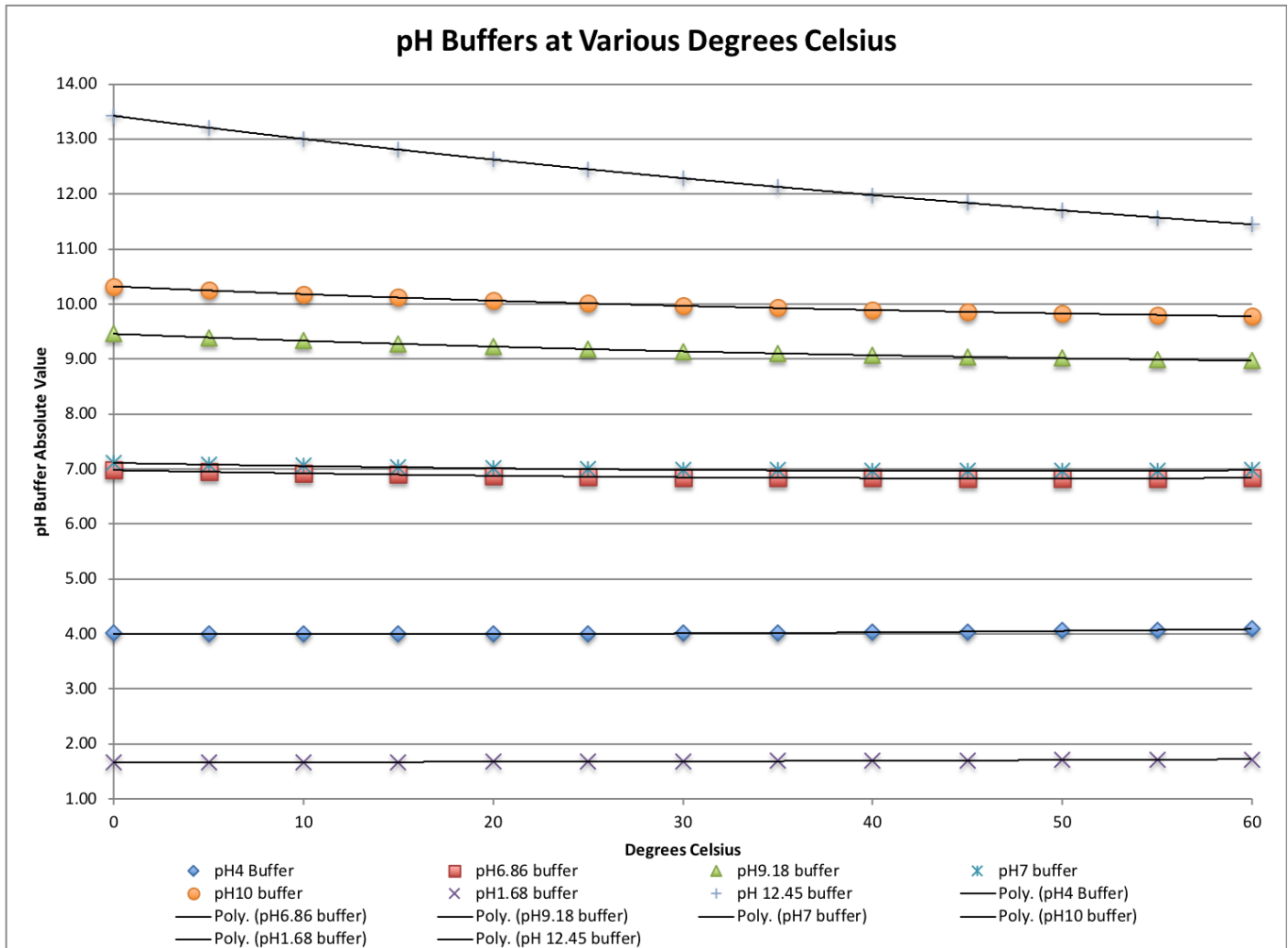

The HiQDT touchscreen controller automatic calibration mode computes the exact values of the pH 1.68, 4.00, 6.86, 7.00, 9.18, 10.01 and 12.45 buffers in the automatic calibration mode for anywhere between 0 to 60 °C. If calibrating with pH buffers in the temperature condition below 0°C or above 60 °C automatic calibration mode cannot be used (manual mode must be used instead). The HiQDT touchscreen controller software can also perform manual calibration to any pH value for Offset, Slope Low (Acidic) or Slope High (Alkaline). In this way this controller is not limited to pH 1.68, 4.00, 6.86, 7.00, 9.18, 10.00 and 12.45 buffers for calibration but rather can perform offset and slope calibrations to any value desired.

Temperature compensation only accounts for the change in the mV response of the pH sensor itself with temperature. The type of temperature induced shifts such as those demonstrated in the table above for the pH buffers are NOT corrected in default Nernstian temperature compensation scheme. For process solutions the change in the pH value with temperature can be significantly more pronounced than for pH buffers which are inherently designed to shift in only the most minimal way due to changes in temperature, dilution, evaporation and other typical conditions in field use. Thankfully the HiQDT-pH sensors allow for a user defined temperature compensation coefficient to account for the NET temperature effects. The temperature impact on the pH sensor and the temperature impact on the measured solution cannot be cleanly separated (deconvoluted). It is, however, possible to determine the effective net mV per °C change and enter this as a custom temperature compensation coefficient. Contact the ASTI factory for assistance with such situations requiring special temperature compensation schemes. The default temperature compensation setting is the classical Nernstian 198µV (0.198mV) per °C with the allowable range of 000-999 µV to any custom value for your given process. The temperature compensation coefficient can be changed by the Windows software or handheld communicator.

## APPENDIX "C"

### *HiQDT-pH " Buffer Choices for Autocalibration*

#### AVAILABLE pH BUFFERS FOR AUTO-CALIBRATION MODE:

Asymmetric Potential (A.P):	7.00 or 6.86
Acid Slope:	4.00 or 1.68
Alkaline Slope:	10.00 or 9.18 or 12.45

#### CALIBRATION SCHEME # 1 – Typical for most installations in the USA

Asymmetric Potential (A.P):	7.00
Acid Slope:	4.00
Alkaline Slope:	10.00

This scheme is the most common pH buffer scheme for most customers in the USA. The 10.01 pH buffer must be used carefully since it is more prone to shifting substantially more than the very stable 4.00 or even the 7.00 pH buffer. Intrusion of carbon dioxide into the 10.01 pH buffer from the atmosphere is the main culprit creating an erroneous non-temperature induced shift in pH by exceeding the buffer capacity. Care should be taken that the pH10 buffer is fresh to ensure reliable alkaline slope calibration results.

#### CALIBRATION SCHEME # 2 – Typical for most installations in Europe

Asymmetric Potential (A.P):	6.86
Acid Slope:	4.00
Alkaline Slope:	9.18

Typical values for most European pH installations are 4.00, 6.86 and 9.18 pH buffers. This is the best practice pH buffer scheme for most pH measurements that do not commonly go much below pH 4.00 and or else much above pH 9.20. The 6.86 & 9.18 pH buffers are most stable than the 7.00 & 10.01 pH buffer counterparts but are still more prone to shifting than the very stable 4.00 pH buffer. Care should be taken that the pH 9.18 buffer is fresh to ensure best alkaline slope calibration results

#### CALIBRATION SCHEME # 3 – For batch style installations where pH can vary quite considerably

Asymmetric Potential (A.P):	1.68
Acid Slope:	6.86
Alkaline Slope:	12.45

This pH buffer calibration scheme is typical for batch type process applications that often go below pH2 and above pH12. The 1.69 and 6.86 pH buffers are quite stable but the 12.45 pH buffer shifts in value quite easily. Great care should be taken when using the 12.45 buffer to ensure accurate results. In particular this buffer should always be in code, well stored in a cool dry place and not exposed to light or air. Make sure that the 12.45 pH buffer is always fresh to ensure reliable alkaline slope calibrations results.

## APPENDIX "D"

### *HiQDT-pH " Best Practice Tips for Calibration with pH Buffers*

#### TEMPERATURE OFFSET CALIBRATION SETUP FOR AUTOREAD:

It is best practice to wait until the temperature reading on the sensor is no longer moving before selecting the setup temperature and starting calibration(s) with pH buffers. The temperature of the sensor may take some time to reach the ambient conditions of the pH buffer solution(s) if it was previously installed into field service at conditions that are significantly below or above the ambient temperature.

#### GENERAL BEST PRACTICE COMMENTS FOR CALIBRATION WITH pH BUFFERS

Only the amount of buffer required for the given calibration should be dispensed. Buffers should not be reused to avoid dilution & cross-contamination. Buffers should not be left exposed to air or direct light for prolonged periods of time to avoid the impact of dissolved carbon dioxide from the atmosphere and other potential decomposition pathways. Special care should be taken the pH buffers above 7.00 are always fresh when used for calibrations as these tend to lose the integrity of their values much faster than pH buffers below 7.00. Buffers should be stored in a cool, dry location away from light and chemicals. The pH sensor should be at a stable ambient temperature before performing any calibration.



**APPENDIX "E"**

## Automatic Calculation of Theoretical 100% Dissolved Oxygen Saturation at any Temperature & Pressure for Accurate Calibration & Measurement

The HiQDT-DO sensor has preprogrammed the correct 100% dissolved oxygen saturation levels valid at any temperature and pressure. This is important for two main purposes: 1) to ensure accurate calibration of the sensor which is performed dry in air and 2) when the percent (%) saturation is displayed and output for purposes of monitoring and control. The graph below demonstrate the impact of both temperature and pressure on the dissolved oxygen (DO) ppm levels that constitute 100% saturation condition.

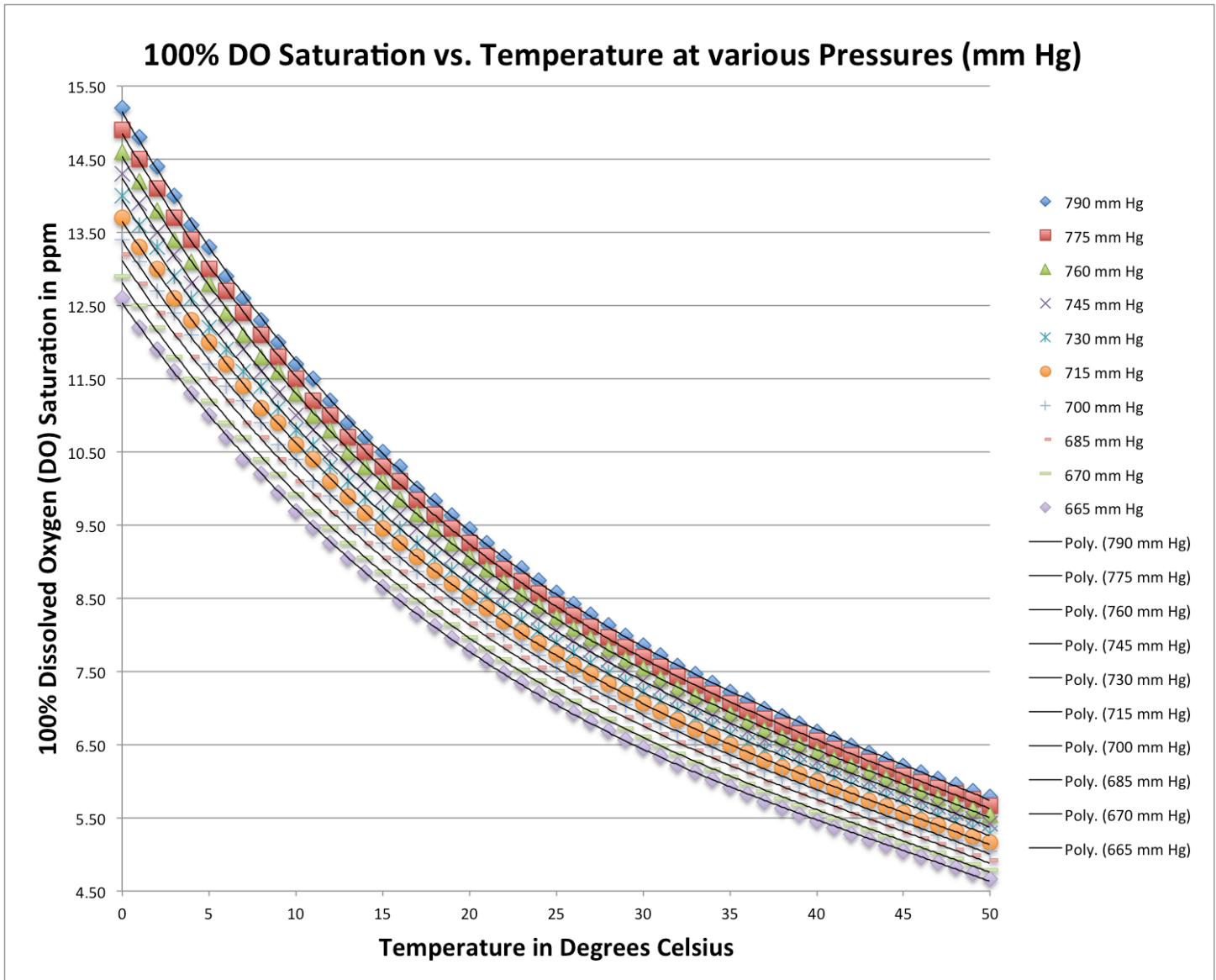

For the calibration function, either the field condition should be 100% relative humidity for best accuracy or else the sensor should be suspended dry in air but over a water source to simulate locally the 100% relative humidity condition. The water molecule in air (humidity) is then saturated with oxygen in manner that can be fully described by the ambient temperature and pressure as shown above. When placed into service, the galvanic DO sensor will measure the ppm levels at the installation depth. To convert this measured ppm value into percent (%) saturation the HiQDT-DO sensor uses the internally stored curve visualization above.

**APPENDIX "F"**

## Automatic Calculation of Theoretical 100% Dissolved Oxygen Saturation at any Temperature & Pressure for Accurate Calibration & Measurement

The HiQDT-DO has preprogrammed the correct 100% dissolved oxygen saturation levels valid at not only any temperature and pressure but also corrected for salinity. This is important for applications where not only fresh water will be present but also for brackish and salt water sources in variable amounts. The graph below demonstrates the impact of salinity on the dissolved oxygen (DO) ppm levels that constitute 100% saturation condition at the nominal 760mm pressure condition. For simplicity of visualization just one set of curves is shown although the analyzer can perform this compensation any temperature, pressure or salinity.

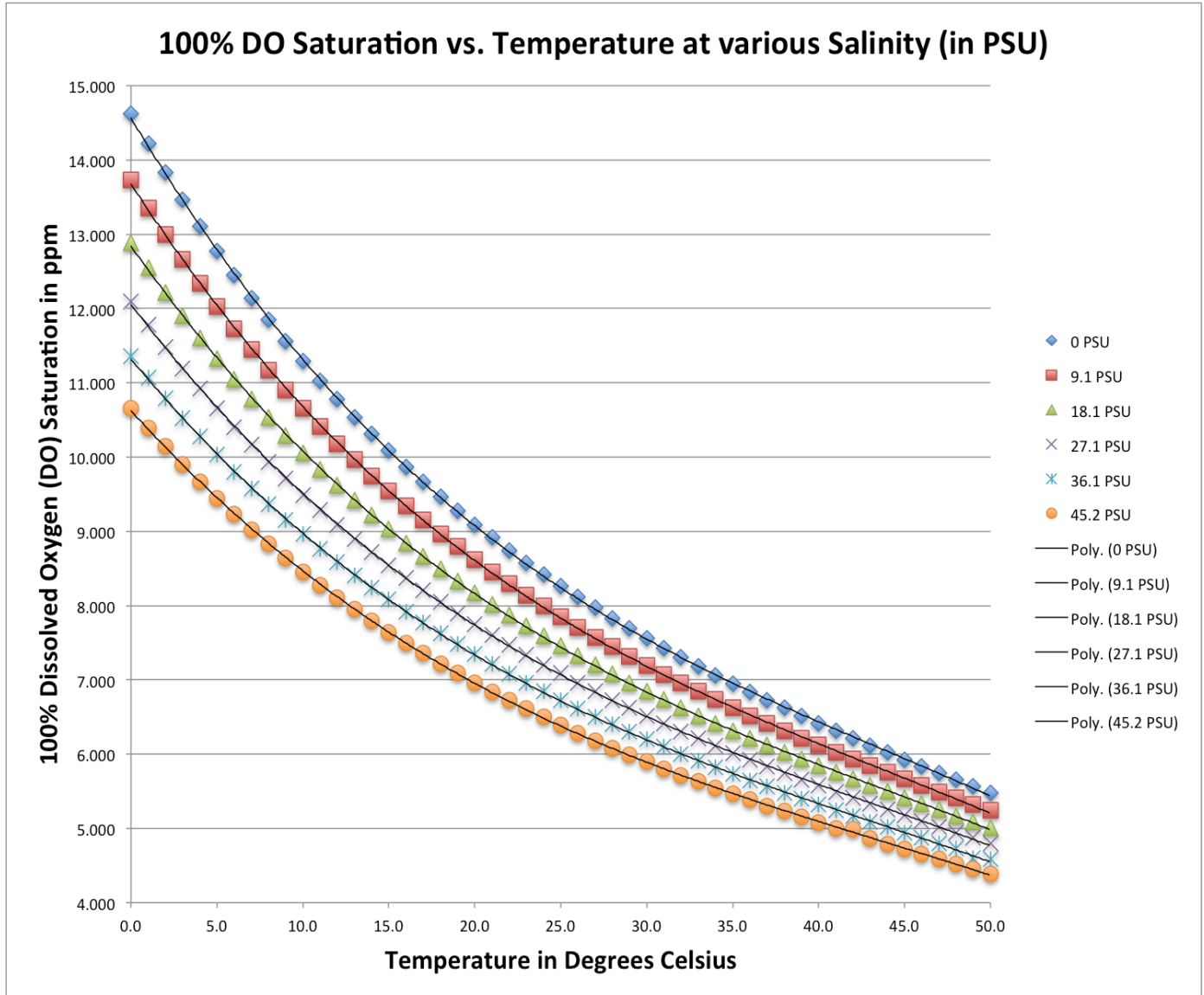

This salinity correction is only required as a correction to the computation of the % saturation from the measured DO ppm levels for the inline measurement. Since the calibration is done dry in air, salinity correction is not required for this part of operation. Since the impact of salinity is considerable as shown in the graph above, it must be corrected carefully at any level of salinity and temperature. The salinity value in standard PSU (PPT) units can be entered into the HiQDT-DO sensor to perform this correction. The value of the salinity can be determined by a handheld meter or else monitoring continuously using a conductivity transmitter from which one can readily convert into common salinity units.

**APPENDIX "G" - PAGE 1 of 4**

**STANDARD RANGE MODE \* - in microSiemens/cm**

Range Scaling Factor 200			Max Temp. Compensated Conductivity using 2% per °C Coefficient			
Cell Constant (K)	Max Raw Input Limit	Resolution	Lowest Recommended Measurement @ 25°C	@ 25 °C	@ 75 °C	@ 125°C
0.01	200	0.004	2	200	100	66.67
0.02	400	0.008	4	400	200	133.33
0.05	1,000	0.02	10	1,000	500	333.33
0.10	2,000	0.04	20	2,000	1,000	666.67
0.20	4,000	0.08	40	4,000	2,000	1,333.33
0.50	10,000	0.2	100	10,000	5,000	33,333.33
1.00	20,000	0.4	200	20,000	10,000	66,666.67
2.00	40,000	0.8	400	40,000	20,000	13,333.33
3.00	60,000	1.2	600	60,000	30,000	20,000.00
5.00	100,000	2	1,000	100,000	50,000	33,333.33
10.00	200,000	4	2,000	200,000	100,000	66,666.67
20.00	400,000	8	4,000	400,000	200,000	133,333.33

**HIGH RANGE MODE \* - in microSiemens/cm**

Range Scaling Factor 2,000			Max Temp. Compensated Conductivity using 2% per °C Coefficient			
Cell Constant (K)	Max Raw Input Limit	Resolution	Lowest Recommended Measurement @ 25°C	@ 25 °C to 75°C	@ 125°C	@ 175°C
0.01	2,000	0.04	20	1000	666.67	500
0.02	4,000	0.08	40	2,000	1,333.33	1,000
0.05	10,000	0.2	100	5,000	3,333.33	2,500
0.10	20,000	0.4	200	10,000	6,666.67	5,000
0.20	40,000	0.8	400	20,000	13,333.33	10,000
0.50	100,000	2	1,000	50,000	33,333.33	25,000
1.00	200,000	4	2,000	100,000	66,666.67	50,000
2.00	400,000	8	4,000	200,000	133,333.33	100,000
3.00	600,000	12	6,000	300,000	200,000.00	150,000
5.00	1,000,000	20	10,000	500,000	3333,33.33	250,000
10.00	2,000,000	40	20,000	1,000,000	666,666.67	500,000
20.00	4,000,000	80	40,000	2,000,000	1,333,333.33	1,000,000

\* **Sensor can toggle between standard/high range mode range mode using handheld communicator.** Standard/high range mode sensor is one configuration & associated sensor board hardware. Ultralow range mode sensor is a different configuration & associated sensor board. While you can toggle between standard and high range modes you cannot toggle between the standard/high and ultralow modes since these are two different sensor boards. Two slope calibrations are stored in dual mode standard/high sensors; slope low is used for standard mode and slope high for the high mode. Slope calibrations are automatically assigned based upon range mode in use for at time when calibration is performed. The ultralow range mode only uses the single low slope (slope high is unused).

SENSOR	CELL CONSTANT										
	0.01	0.02	0.05	0.10	0.20	1.00	2.00	3.00	5.00	10.00	20.00
AST10	Red	Red	Red	Red	Red	Red	Red	Red	Red	Red	Red
AST51	Red	Red	Red	Red	Red	Red	Red	Red	Red	Red	Red
AST41	Red	Red	Red	Red	Red	Red	Red	Red	Red	Red	Red
ASTXX-TRI	Red	Red	Red	Red	Red	Red	Red	Red	Red	Red	Red
AST42	Red	Red	Red	Red	Red	Red	Red	Red	Red	Red	Red
AST40	Red	Red	Red	Red	Red	Red	Red	Red	Red	Red	Red
AST50	Blue	Blue	Blue	Blue	Blue	Blue	Blue	Blue	Blue	Blue	Blue
AST60	Blue	Blue	Blue	Blue	Blue	Blue	Blue	Blue	Blue	Blue	Blue
AST52	Blue	Blue	Blue	Blue	Blue	Blue	Blue	Blue	Blue	Blue	Blue

Color Coding  Available in Cell Constant  
 Not available in that Cell Constant

*All contacting conductivity sensors are available in smart digital MODBUS RTU configuration although not all cell constants are available for each model. Use the standard & high range mode cell constant table above & ultralow range mode table below to determine most suitable selection for your sample. Cell constants above K=2.00/cm omitted from ultralow range table but available on request.*

**ULTRA-LOW RANGE MODE** - in microSiemens/cm

Range Scaling Factor 2			Max Temp. Compensated Conductivity using 2% per °C Coefficient			
Cell Constant (K)	Max Raw Input Limit	Resolution	Lowest Recommended Measurement @ 25°C	@ 25°C	@ 75°C	@ 125°C
0.01	2	0.00004	0.02	2	1	0.667
0.02	4	0.00008	0.04	4	2	1.333
0.05	10	0.0002	0.1	10	5	3.333
0.10	20	0.0004	0.2	20	10	6.667
0.20	40	0.0008	0.4	40	20	13.333
0.50	100	0.002	1.0	100	50	33.333
1.00	200	0.004	2.0	200	100	66.667
2.00	400	0.008	4.0	400	200	133.33

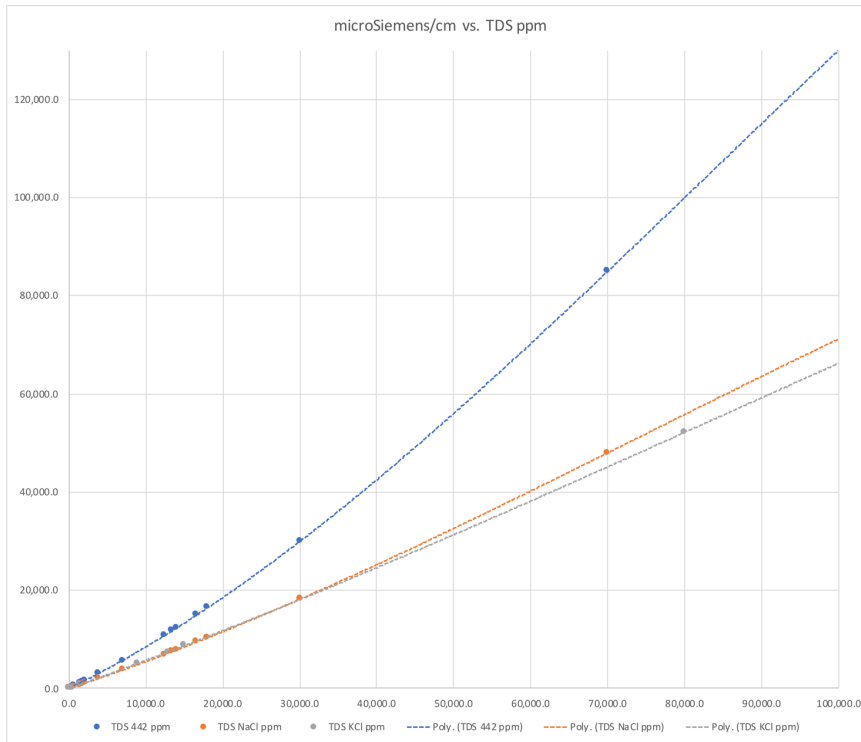

**Total dissolved solids (TDS) units** are computed from measured conductivity. The curves that define relationship between the measured conductivity and user selectable total dissolved solid (TDS) units of NaCl, KCl or 442 are preprogrammed into sensor with full range of 0 to 100,000 ppm. The actual usable range may be limited by the choice of cell constant and range mode in which the sensor is operated.

Other types of total dissolved solids (TDS) for other electrolytes or electrolyte mixtures can be programmed into the sensor on a special-order basis (minimum order requirements apply for such special programming requests). Inquire to the factory if you have need for such special TDS units for your smart digital HiQDT MODBUS RTU conductivity sensors.

**µS/cm @ 25°C vs PSU**

**Salinity computed from the measured conductivity.** Curves that define the relationship between measured conductivity and the computed salinity in PSU are preprogrammed into the sensor with a full range of 0.000 to 50.000 PSU.

The actual supported range may be limited by cell constant & range mode used). Contact the factory to determine the most suitable sensor model and cell constant configuration for your desired salinity range of interest.

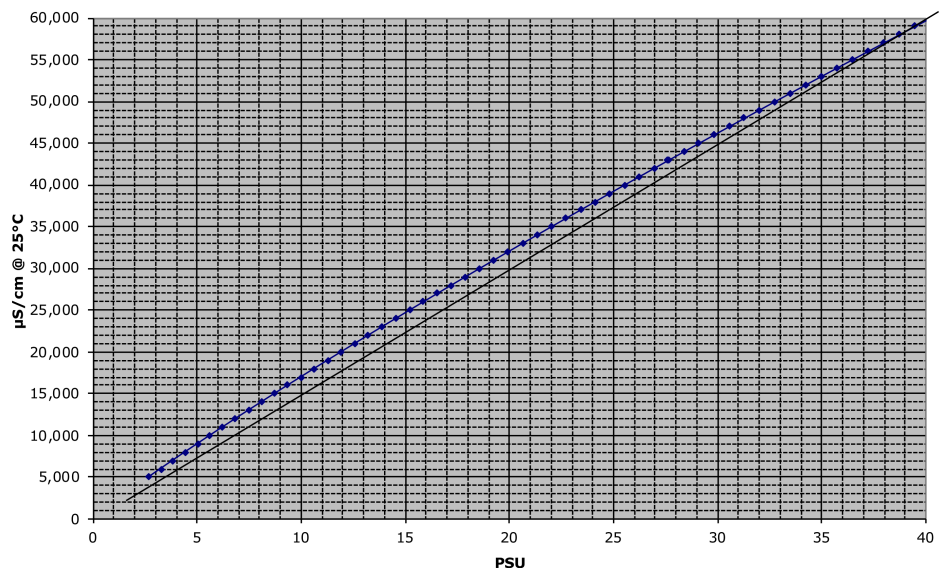

## Ultralow Range Conductivity Sensors for Ultrapure Water (UPW)

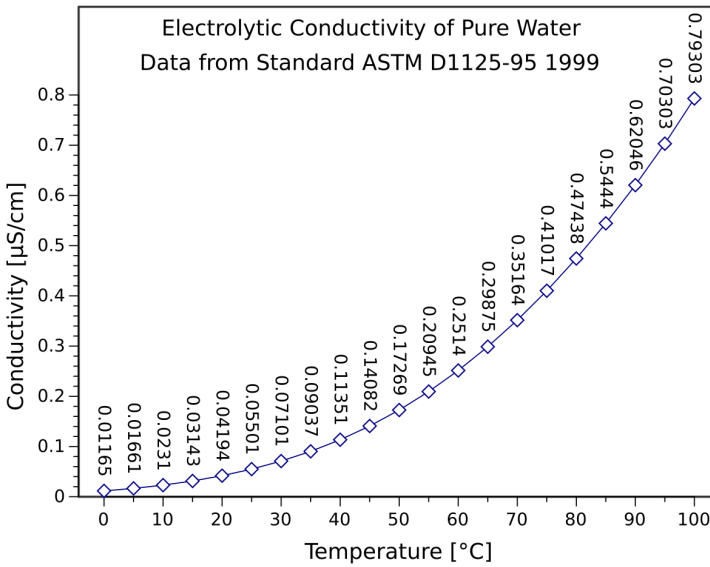

The conductivity of pure water varies significantly with temperature in a well-defined but non-linear fashion as detailed in the graph to left. This behavior is preprogrammed into the HiQDT-CON-L MODBUS RTU conductivity sensors for the automatic temperature compensation feature to make it suitable for ultrapure water (UPW) type applications.

Although the recommended cell constant for performing conductivity measurement in UPW is  $K=0.01/cm$  for best resolution and lower bounds of measurement there may be situations where this  $K=0.01/cm$  cell constant cannot be used for the planned installation location because of limitations such as piping arrangement and low-flow. The higher cell constants of  $K=0.05/cm$  or  $K=0.10/cm$  can be used instead in such cases albeit they require the sample to be at a higher temperature to ensure best results. Table below details recommended minimum temperature for various cell constants for use in UPW. The minimum temperature for UPW measurement for each cell is determined based upon the lowest absolute conductivity value for which the cell constant is recommended & temperature at which this conductivity occurs for UPW. Resistivity are computed units are the inverse of the measured conductivity value.

### ULTRA-LOW RANGE MODE - MicroSiemens/cm

Range Scaling Factor					
2					
Cell Constant (K)	Raw Max Input @ 25°C	Resolution	Lowest Recommended Absolute Measurement	Minimum Temp °C *	Absolute MegaOhm (MΩ) @ Min Recommended °C *
0.01	2	0.00004	0.02	8	50
0.05	10	0.0002	0.1	40	10
0.10	20	0.0004	0.2	55	5

\* Minimum recommended temperature is conductivity of UPW which is 1% of ultralow range mode for the given cell and the associated MegaOhm units. Measurements can be performed below the recommended minimum temperature with an associated higher uncertainty for those situations.

For ultralow range conductivity sensors the 5<sup>th</sup> read input register (30005) sends the computed resistivity MegaOhm (MΩ) using the user defined linear automatic temperature compensation (ATC) while the 6<sup>th</sup> read input register (30006) sends computed resistivity MegaOhm (MΩ) using the special non-linear ultrapure water style automatic temperature compensation. The resistivity values sent as 0 to 50,000 steps corresponding to 0.000-50.000 MegaOhm (MΩ) for both the 5<sup>th</sup> (30005) & 6<sup>th</sup> (30006) read input registers. Theoretical temperature compensated resistivity value can never go above 18.18 MegaOhm (MΩ) for uncontaminated pure water since this is the ideal value at 25 degrees Celsius.

Temperature compensated conductivity and resistivity are referenced back to the 25 °C condition for all ATC. Ultrapure water with no contaminants has a value of 0.055 µS/cm conductivity or 18.18 MΩ in resistivity. The most common units for measurement of pure water is resistivity (MΩ) MegaOhm due to high resolution and convenient scaling in the very low conductivity levels. Temperature compensated conductivity and computed resistivity values sent for the ultralow range mode smart digital HiQDT-CON-L style MODBUS RTU conductivity sensors as well as the raw conductivity.

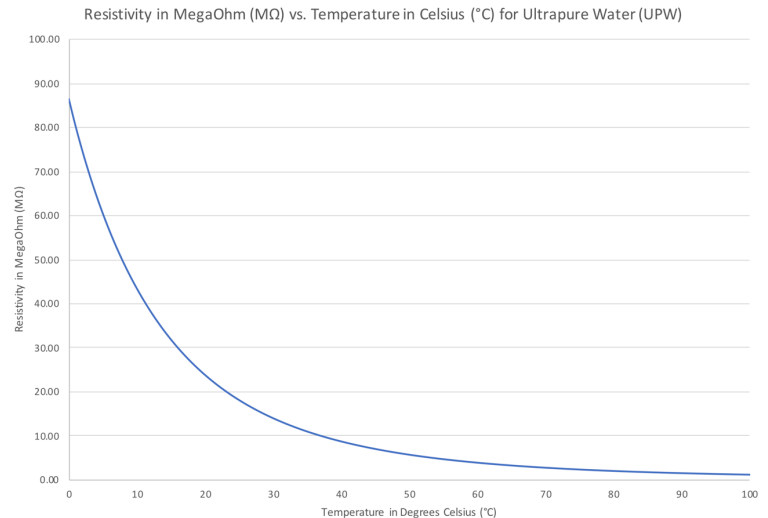

Graph above shows relationship between the resistivity of pure water at various temperatures. Computed resistivity MegaOhm (MΩ) units are the inverse of measured conductivity and so are the mirror image of the conductivity at various temperatures for ultrapure water (UPW). Graph above shows absolute raw resistivity at various temperatures. Resistivity values sent include ATC referencing reading to 25 °C state.

## HiQDT-CON-ISO-L-10X SENSOR CELL & RANGE TABLE FOR ULTRALOW-10X HARDWARE

**ULTRA-LOW RANGE MODE 10X \*** - in microSiemens/cm

Range Scaling Factor		2		Max Temp. Compensated Conductivity using 2% per °C Coefficient			
Nominal Cell Int **	ACTUAL Cell Constant	Max Raw Input Limit	Resolution ***	Lowest Recommended Measurement @ 25°C	@ 25°C	@ 75°C	@ 125°C
10	0.01	20	0.0004	0.2	20	10	6.667
20	0.02	40	0.0008	0.4	40	20	13.333
50	0.05	100	0.002	1.0	100	50	33.333
100	0.10	200	0.004	2.0	200	100	66.667
200	0.20	400	0.008	4.0	400	200	133.33
500	0.50	1,000	0.02	10.0	1,000	500	333.33
1000	1.00	2,000	0.04	20.0	2,000	1,000	666.667
2000	2.00	4,000	0.08	40.0	4,000	2,000	1,333.33

\* Range mode defined by register 40018. When register 40018 is 2 then range scaling factor is ultralow mode. **This register 40018 is read only for the ultralow mode sensor type.**

\*\* The nominal cell constant of conductivity sensor is found by dividing integer obtained from register 40019 by 100.

\*\*\* The resolution is always 50,000 steps no matter the nominal cell constant of sensor or range mode that is in operation.

If sensor used is only ever just one cell constant and range mode, then simple scaling of 0-50,000 steps to conductivity range is possible. Procedure below supports any cell constant in any range mode without changing programming of MODBUS RTU master PLC device:

### 1) Converting registers 30001 & 30003 for conductivity sensors into µS/cm conductivity units

To display calibrated & temperature compensated conductivity in µS/cm units, use the following formula:

$$\mu\text{S/cm} = ((\text{REG30001} * \text{REG40019}) * \text{REG40018}) / 50,000$$

To display calibrated raw conductivity in µS/cm units use register 30003 instead of 30001 in formula above.

### 2) Converting µS/cm conductivity units into native 0-50,000 step sensor resolution units

When performing the autocalibration calls on the conductivity sensor you will need to convert from the engineered µS/cm conductivity units to the 0 to 50,000 native resolution units of the conductivity sensor using this formula:

$$\text{Native 0-50,000 sensor resolution units} = (\mu\text{S/cm} * 50,000) / (\text{REG40019} * \text{REG40018})$$

Native 0-50,000 sensor resolution units are what is sent to register 40011 (ultralow slope).

### **SPECIAL NOTES ABOUT ULTRALOW-10X STYLE SPECIAL ORDER SENSORS:**

It is not possible to tell whether the sensor that you have is the Ultralow style or the Ultralow-10X style simply from looking at register 40018 since this would be 2 in both cases. The only way to tell that you have the Ultralow-10X style hardware is that the nominal cell constant detailed in register 40019 will be 10 times higher than the actual cell constant as indicated on the sensor label. This ten-fold deviation between the nominal and the actual cell constant is what is to be expected if you have purchased the Ultralow-10X style sensor. The range of the Ultralow-10X follows what would be expected if the actual cell constant was ten times higher for the same ultralow sensor configuration. Contact factory if you should have any questions or concerns prior to ordering.

# SERPAC I352HL

Electronic Enclosures

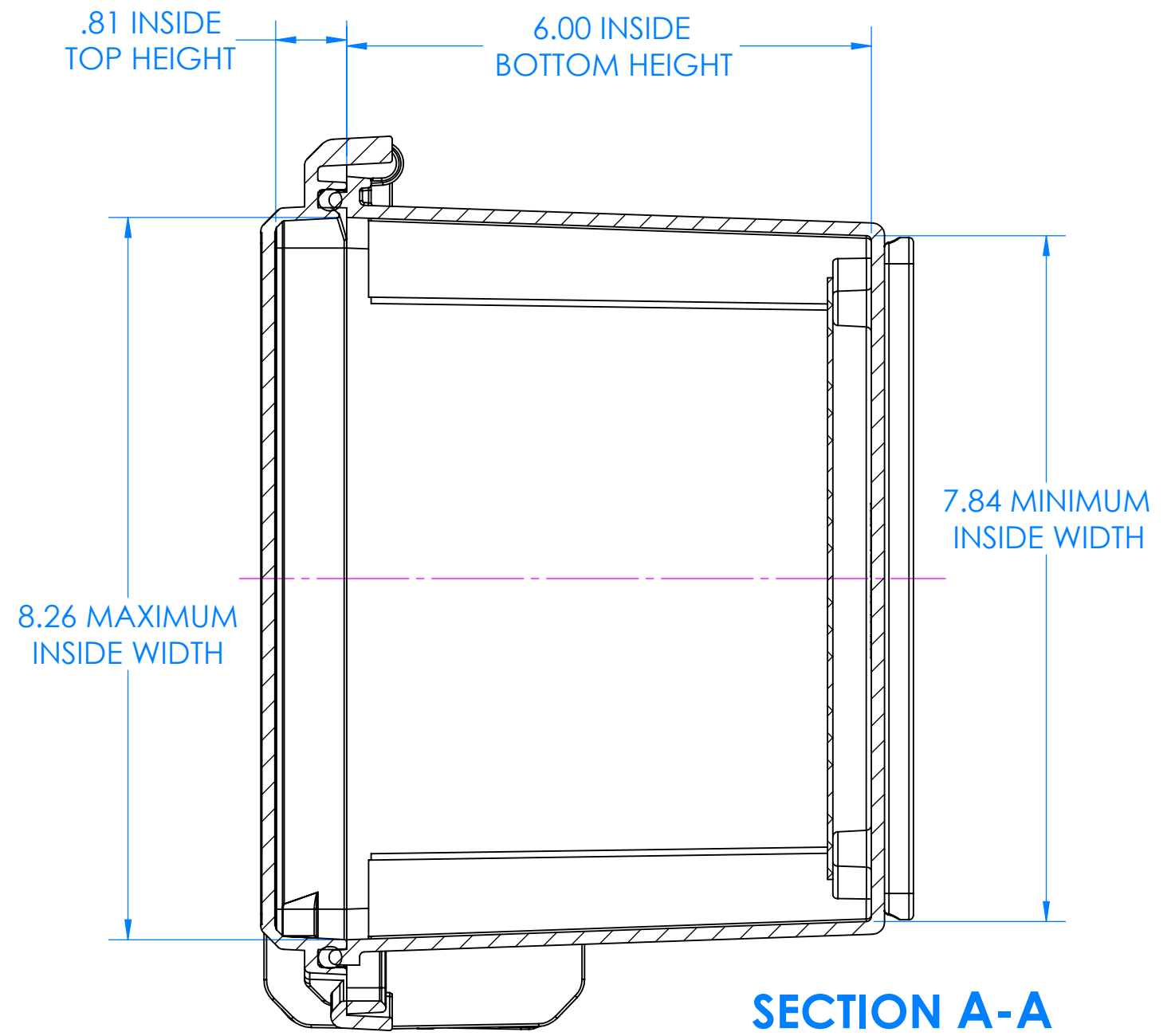
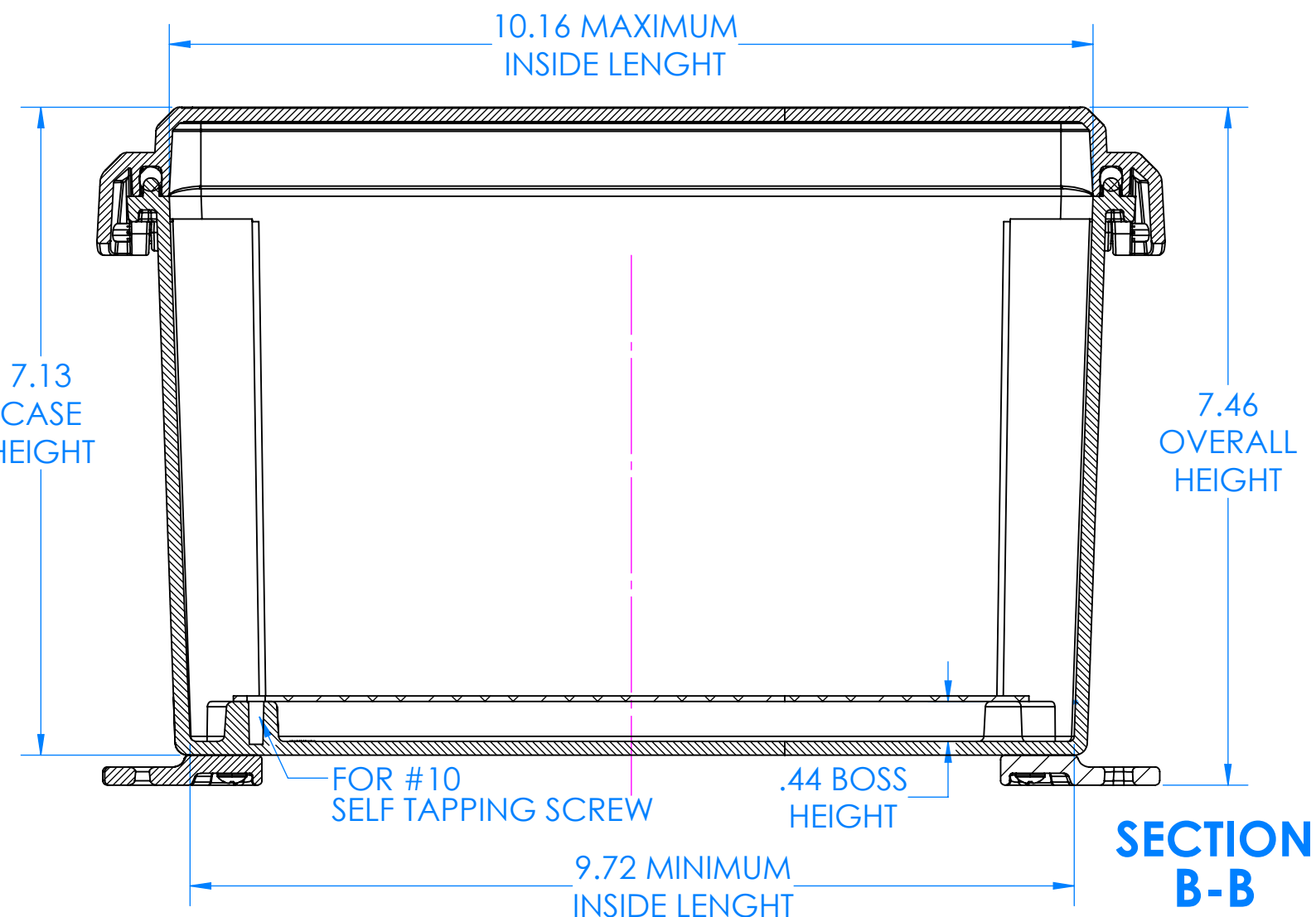
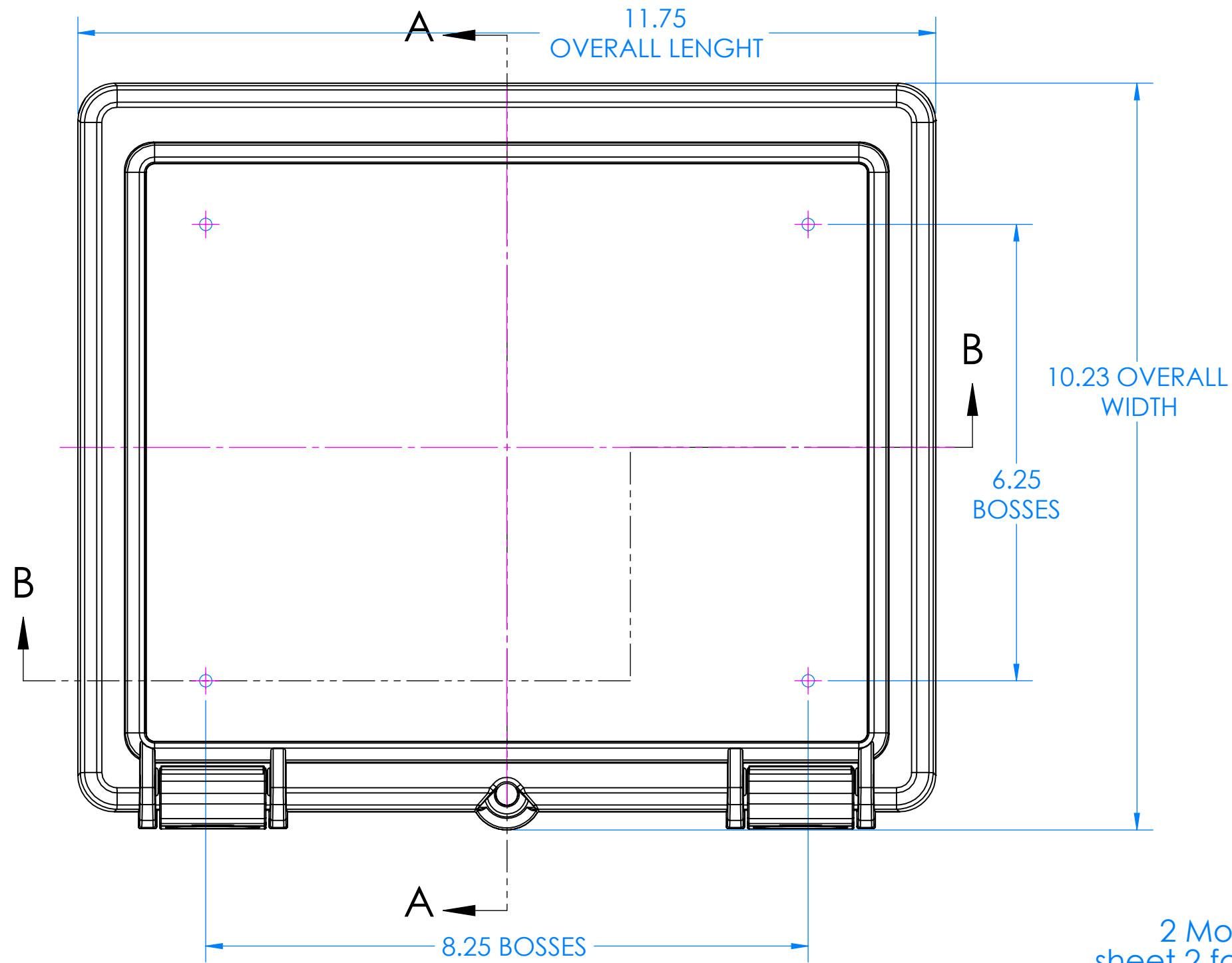

2 Mounting Brackets included, see sheet 2 for dimensions and for optional mounting Corner Feet and Brackets.

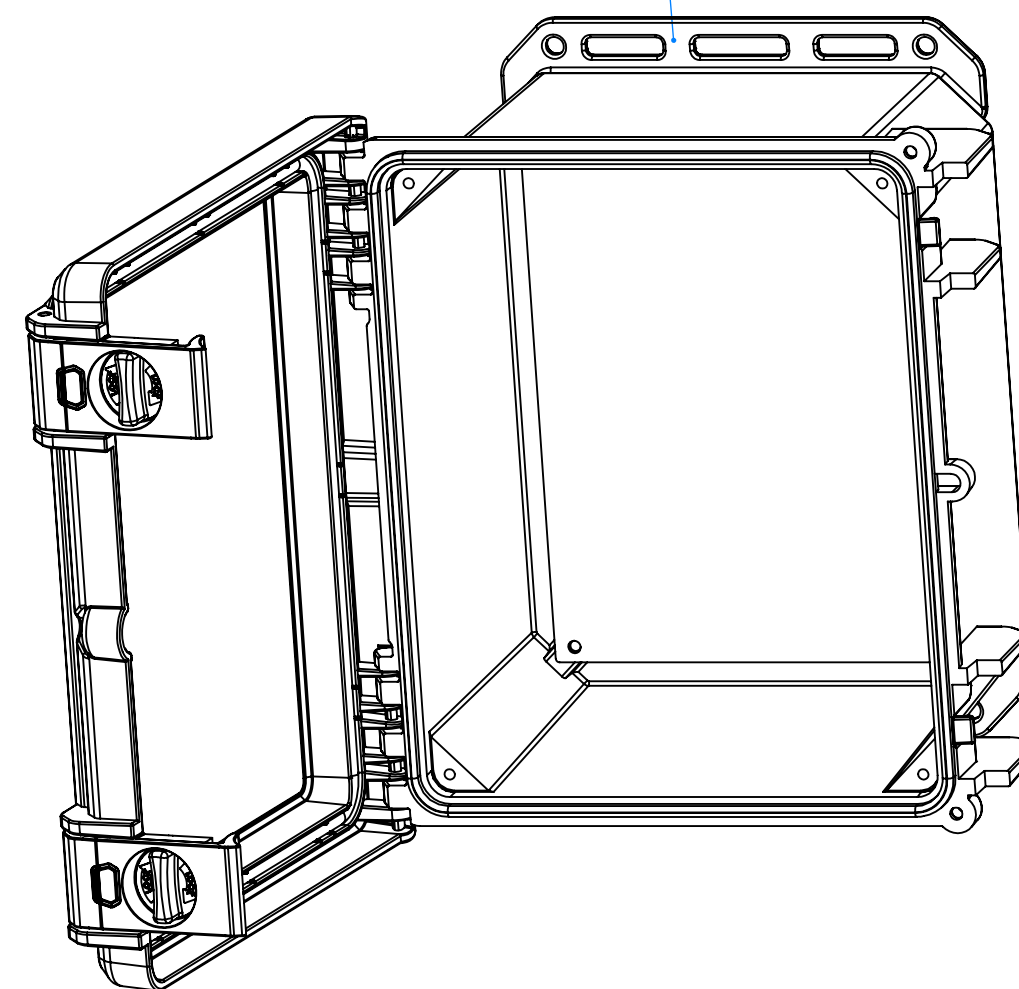

Aluminum and Plastic Panel Kits are available as options, see sheets 3-6. The aluminum panel options are:  
 Bottom Panel Kit p/n 7200B  
 Top Panel Kit p/n 7200T  
 Hinged Panel Kit p/n 7200TH  
 The plastic panel option is:  
 Hinged Panel Kit p/n 7200HP

-Material: UV stabilized Polycarbonate  
 Flammability UL 94 V-0  
 -Watertight enclosure meets or exceeds Nema 4 and or IP67.

PARTS INCLUDED		
P/N	Qty.	Description
I352 HLT	1	I352 Hinged Latch Top
I350 HLB	1	I350 Hinge Latch Bottom
8350	1	350 Perimeter O-ring
7011PCM	2	Safety Latch for I-series (PC)
1305	2	Mounting Bracket
6028	4	SS #10 X 5/8" Pan H/L

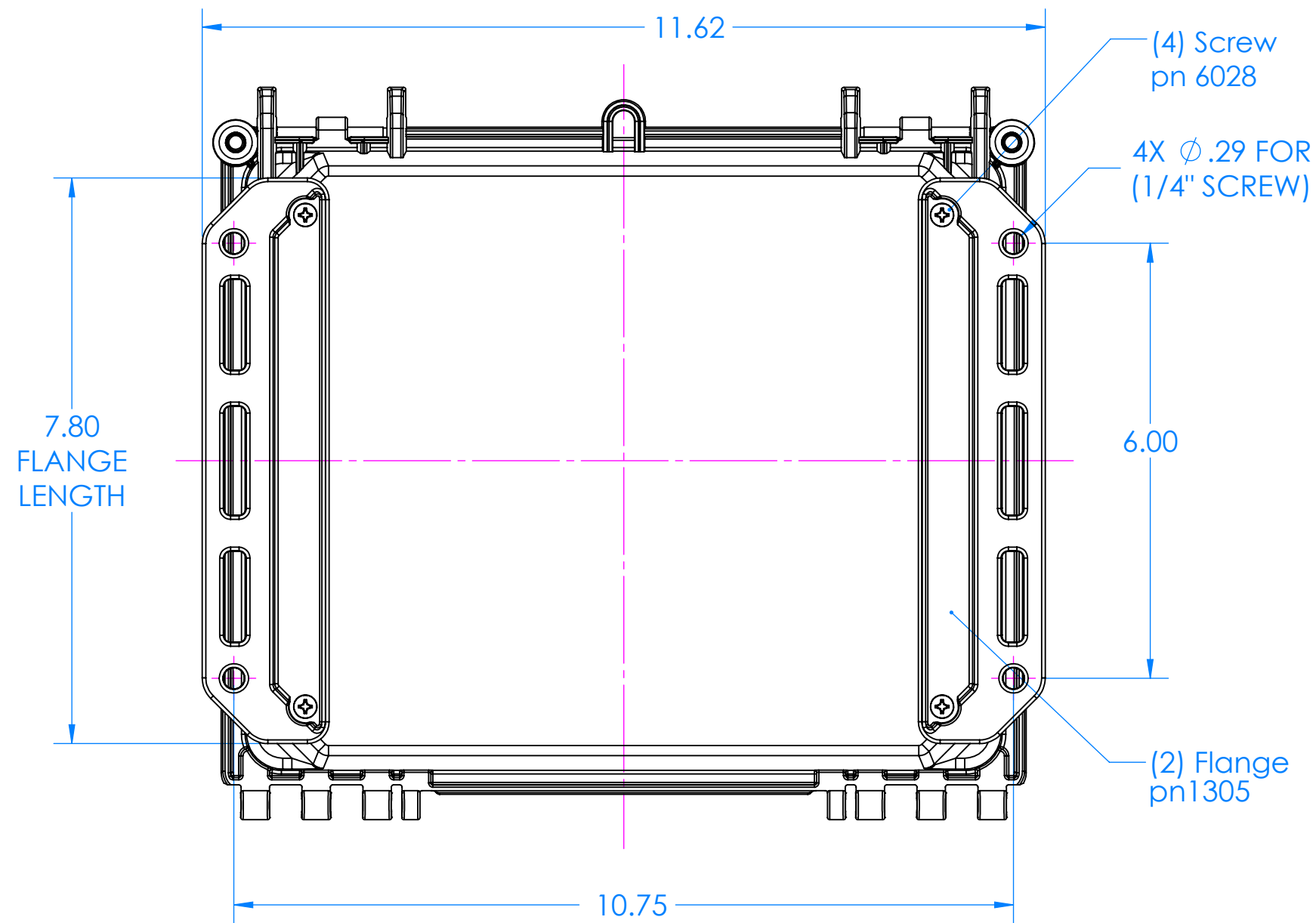

### INCLUDED STANDARD 1305 FLANGE KIT

Part included with Kit number 1305		
P/N	Qty.	Description
1305	2	Flange
6028	4	SS #10 X 5/8" Pan Combo H/L Screw

TOP & LATCHES REMOVED FOR CLARITY FROM ALL VIEWS

### OPTIONAL 1306 CORNER FEET KIT

Part included with Kit number 1306		
P/N	Qty.	Description
1306	4	Mounting Corner Foot
6028	4	SS #10 X 5/8" Pan Combo H/L Screw

### OPTIONAL 1355 CORNER BRACKETS KIT

Part included with Kit number 1355		
P/N	Qty.	Description
1355	4	Mounting Corner Bracket
6028	4	SS #10 X 5/8" Pan Combo H/L Screw

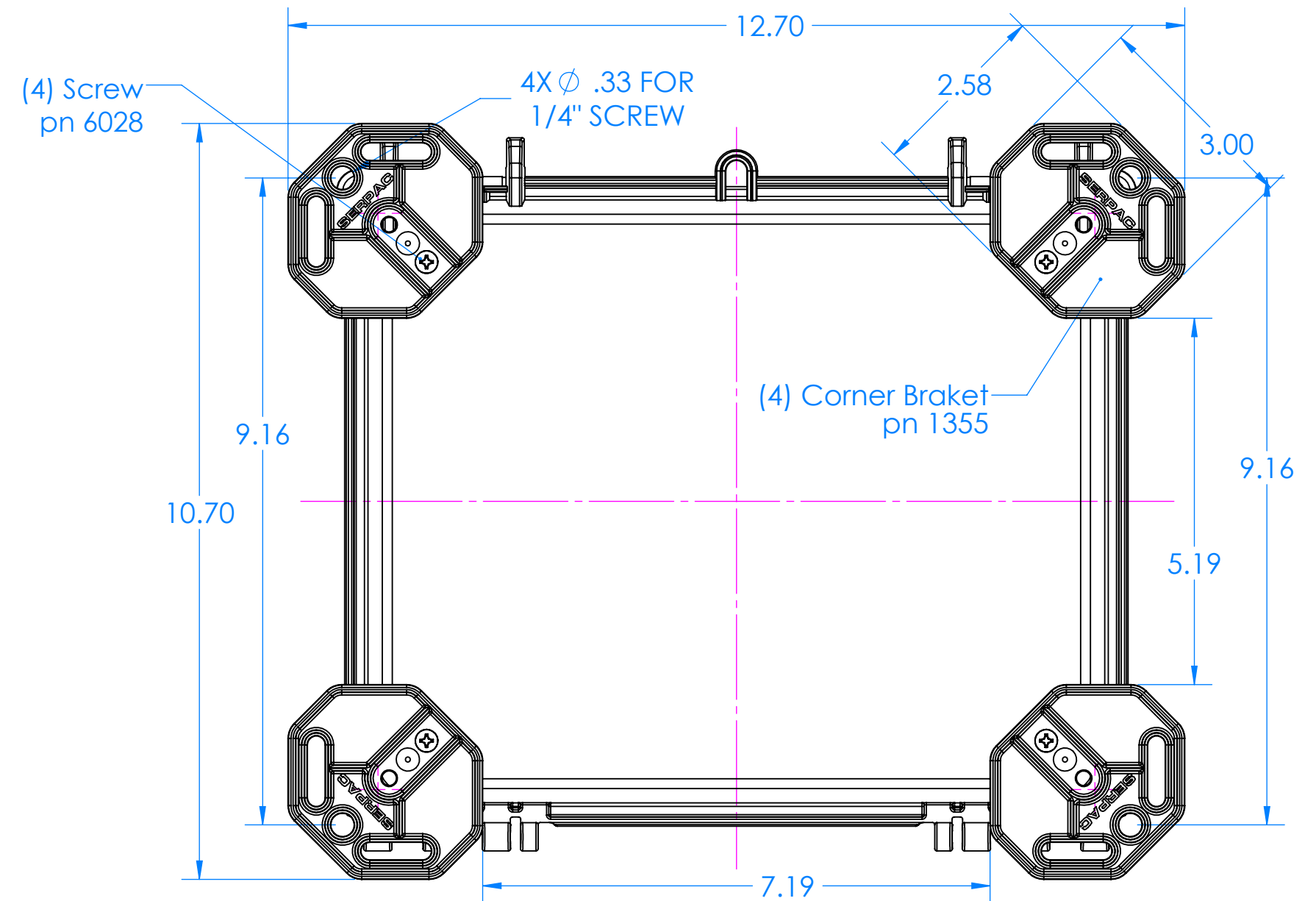
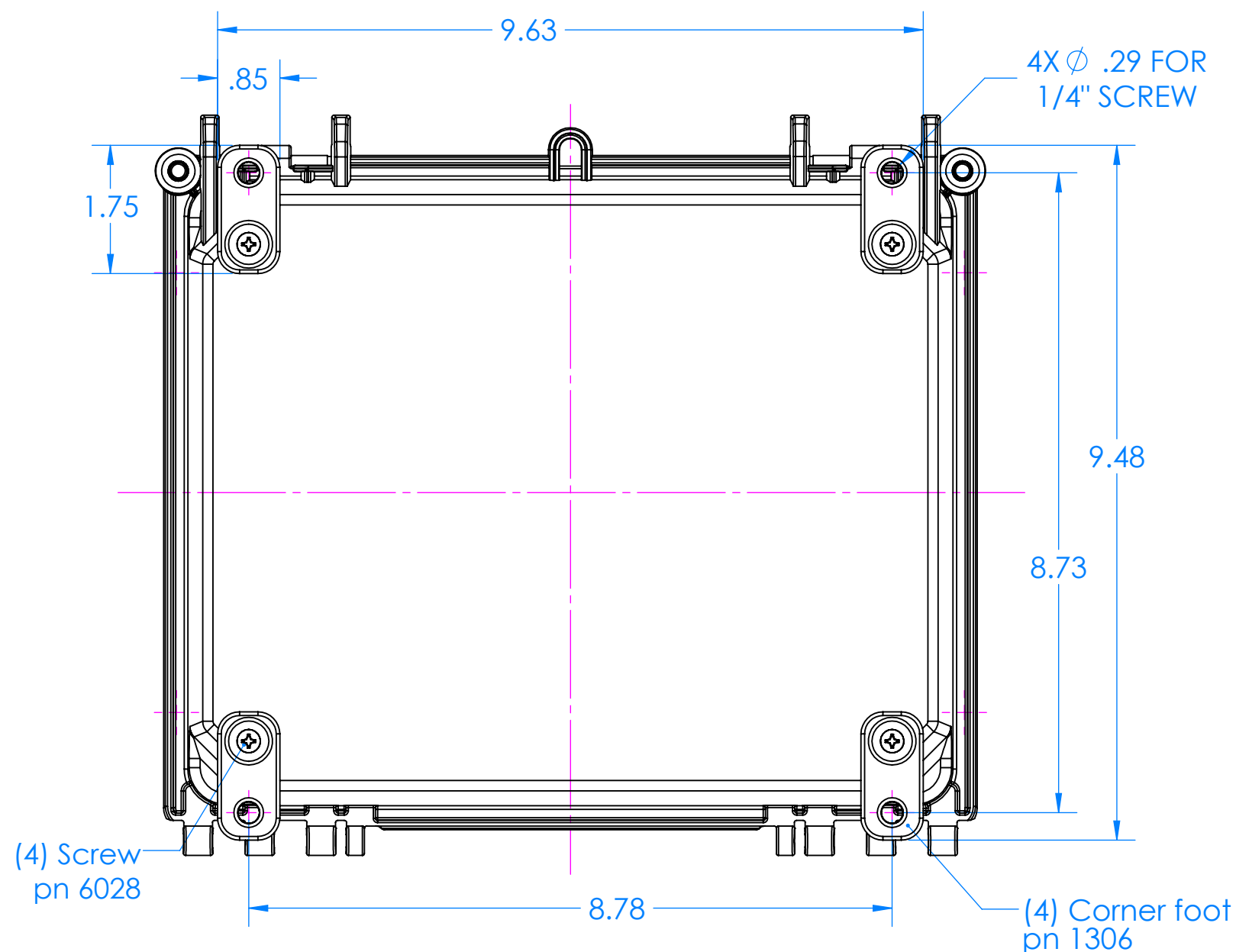



# 7200B Bottom Panel Kit for 352HL, 342HL, 352HS, 342HS, 352S and 342S

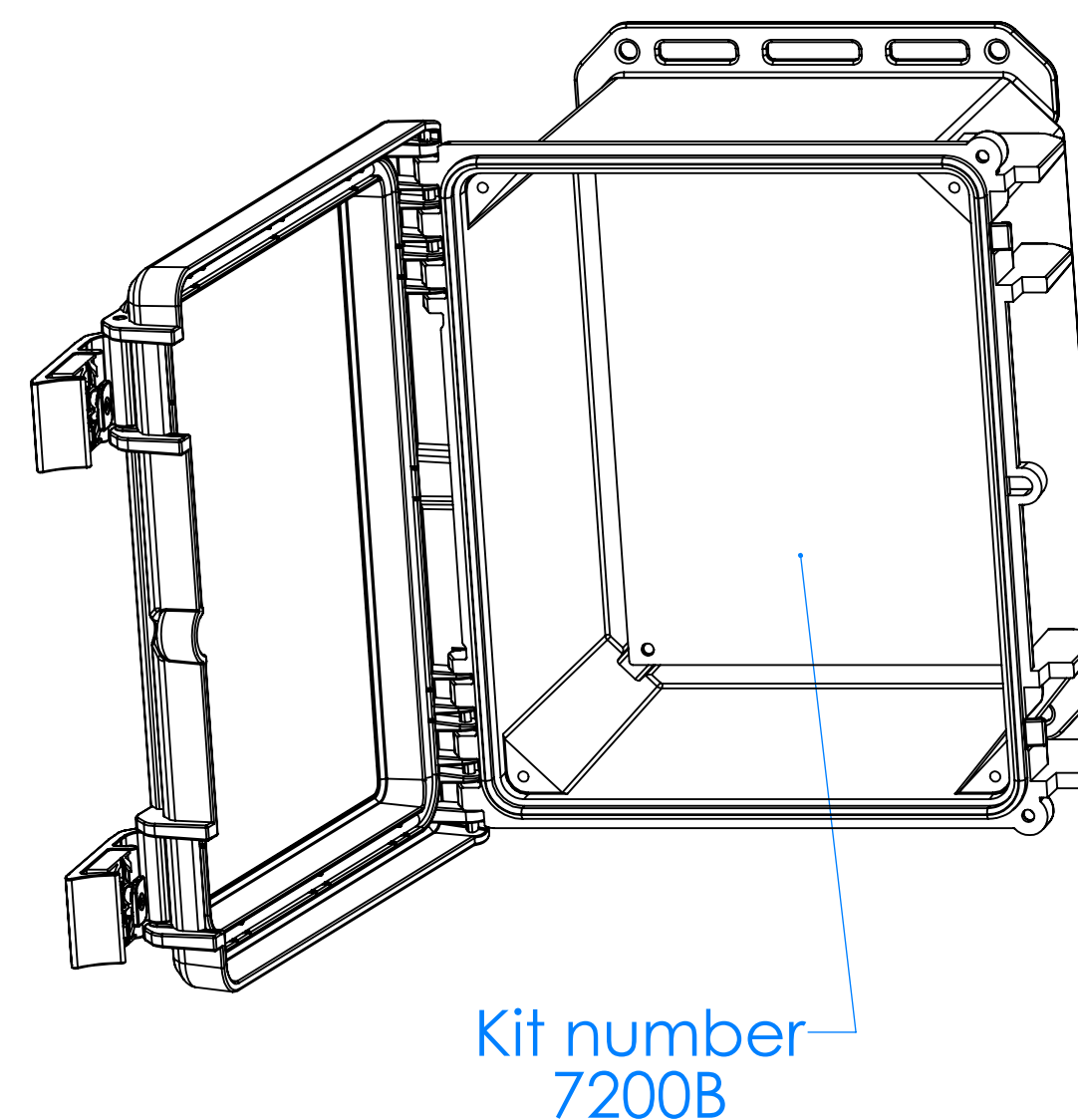
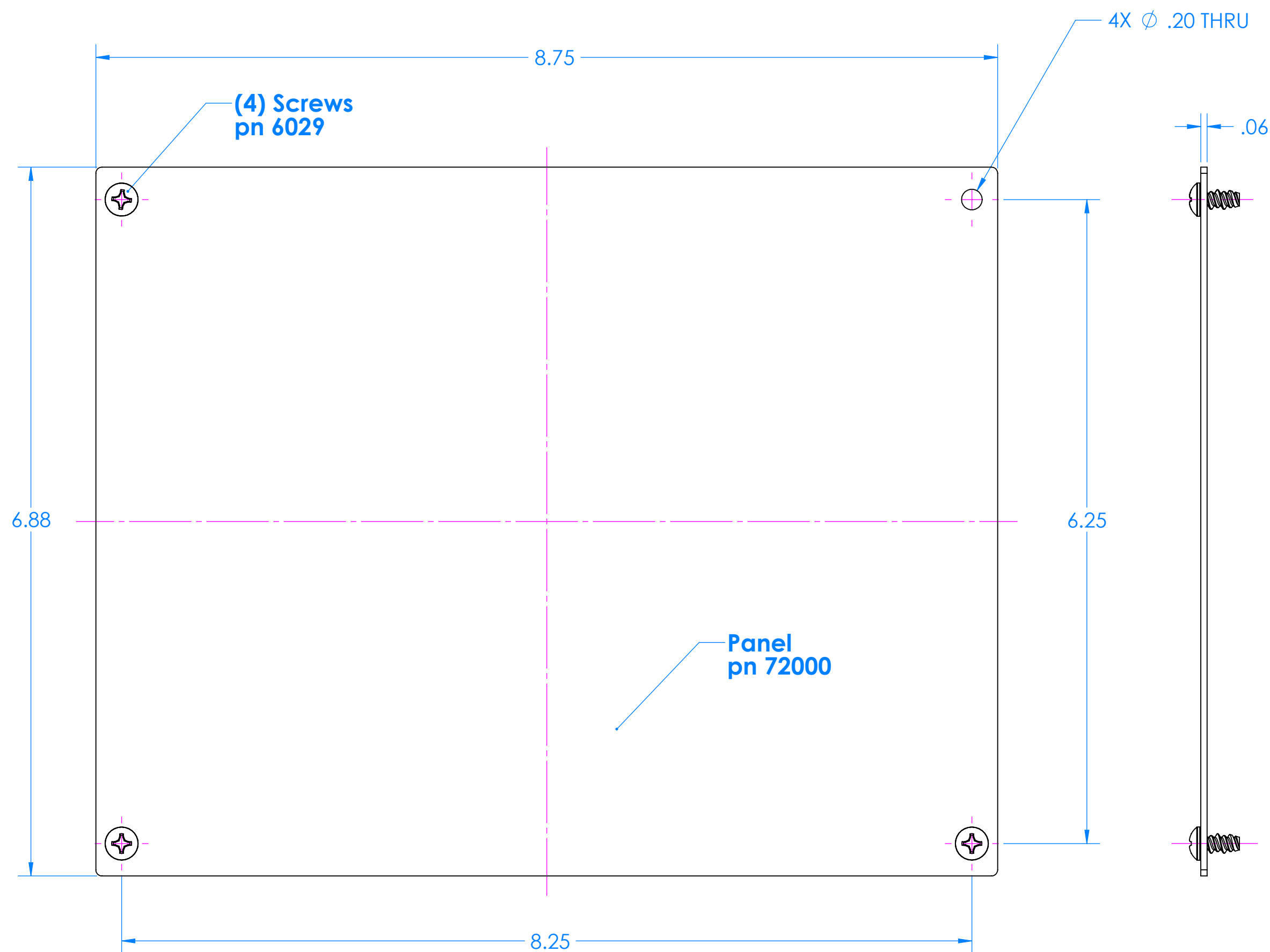

Part included in Kit number 7200B		
P/N	Qty.	Description
72000	1	Bottom Aluminum Panel
6029	4	SS #10 X 3/8" Pan HL Screw

# 7200HP Hinged Top Plastic Panel Kit for 352HL, 342HL, 352HS, 342HS, 352S and 342S

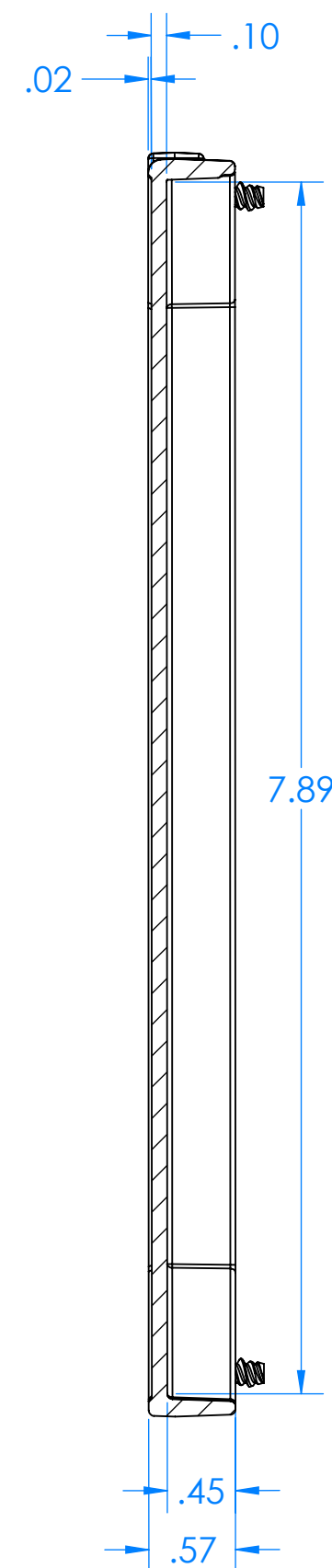
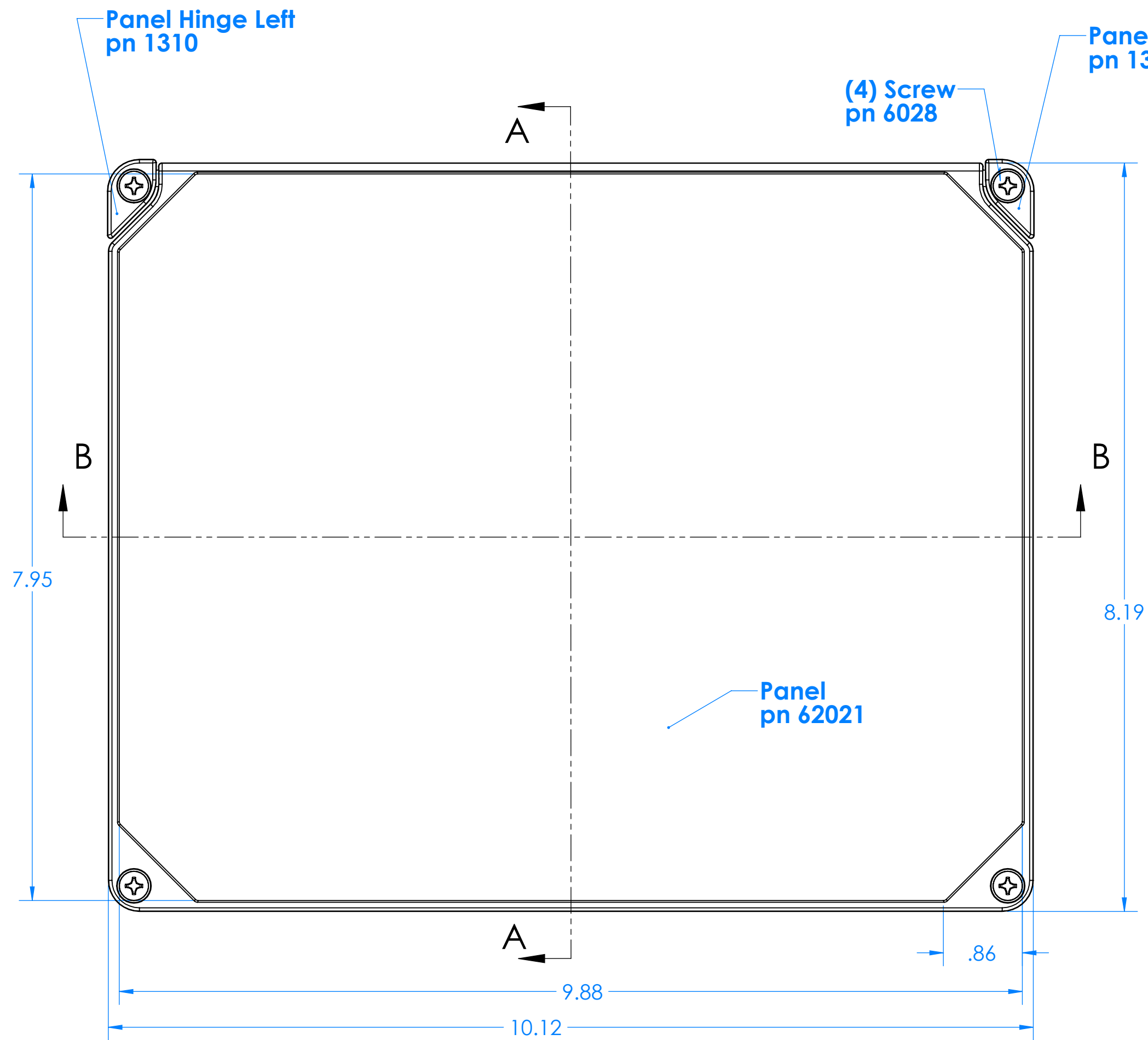

**SECTION A-A**

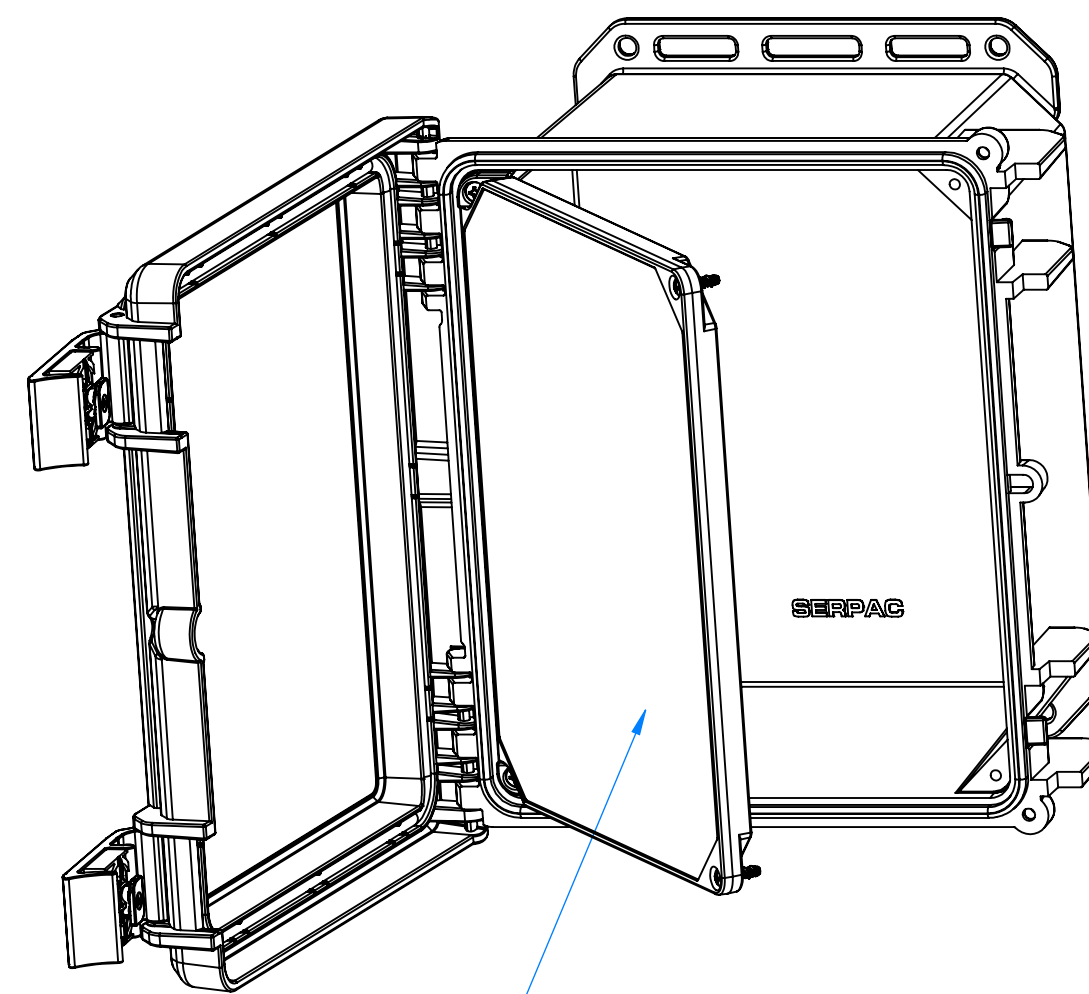

Kit number  
7200HP

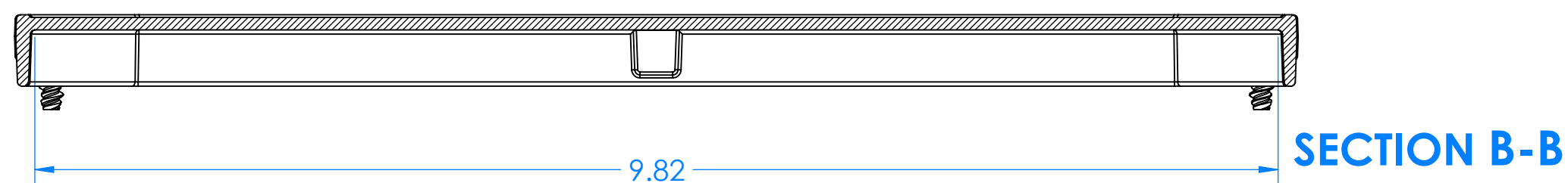

**SECTION B-B**

Parts Included in kit number 7200HP		
P/N	Qty.	Description
72021	1	Hinged Top Plastic Panel
1310	1	Panel Hinge Left
1311	1	Panel Hinge Right
6028	4	SS #10 X 5/8" Pan H/L Screw

---

## ASTI HiQDT Touchscreen Controller for Smart Digital MODBUS RTU Sensors End User License Agreement (EULA)

Revision 9.2 October 2021

This Agreement is made between the parties

1. This software license agreement shall be inclusive of any and all parties that are involved in any form on behalf of *the ASTI HiQDT Touchscreen Controller Development Team*.
2. The **LICENSEE**, being the individual, research group, institution or organization, or agent who uses the ASTI HiQDT Touchscreen Controller for HiQDT Smart Digital Sensors (**SOFTWARE**) comprising the software programs, runtime/shared libraries and all the associated documentation.

The **SOFTWARE** is loaded at the factory onto the Maple Systems hardware from *the ASTI HiQDT Touchscreen Development Team*. The copyright and other intellectual property rights in the **SOFTWARE** are the property of *the ASTI HiQDT Development Team*. *The ASTI HiQDT Development Team* reserves the right to grant of use to **LICENSEE** and issues the release of software to **LICENSEE** at its sole discretion.

By using the **SOFTWARE**, the **LICENSEE** accepts all of the terms and conditions of this Agreement, those being:

1. The **SOFTWARE** name(s) are trademarks or registered trademarks of *the ASTI HiQDT Touchscreen Development Team*. The **SOFTWARE** and related documentation are copyrighted works of authorship. *ASTI HiQDT Touchscreen Development Team* retains ownership of the **SOFTWARE** name(s), **SOFTWARE** and all subsequent copies of the **SOFTWARE**, regardless of the form in which the copies may exist. This license agreement does not constitute a sale or any form of transfer of ownership of the **SOFTWARE**.
2. The **LICENSEE** shall provide valid and accurate contact information as requested by *the HiQDT Development Team*.
3. The **SOFTWARE** is licensed for use by the **LICENSEE** only. The **LICENSEE** may not rent, lease, sub-license, sell, assign or otherwise transfer the **SOFTWARE** without the prior written consent of *the ASTI HiQDT Touchscreen Development Team*. However, the **LICENSEE** may create a limited number of copies of **SOFTWARE** as required for **LICENSEE's** operations, but solely for **LICENSEE's** own usage. Should this be the case, these copies will be subject to the same License Agreement as applied to the original **SOFTWARE**. The **LICENSEE** may use any of the revision of the binaries that are provided as the part of **SOFTWARE**, within the scope of a single License Agreement.
4. The **LICENSEE** will not assign or transfer this Agreement, or any rights or obligations hereunder, without first obtaining the written consent of *the ASTI HiQDT Touchscreen Development Team*. Upon such assignment, however, the **LICENSEE** shall cease all use of the **SOFTWARE**, and destroy all copies of the **SOFTWARE** immediately.
5. The **LICENSEE** shall not disclose any part of the **SOFTWARE** to any third party, and shall ensure that the **SOFTWARE** is protected against unauthorized copying.
6. The **LICENSEE** may not extract any part of the **SOFTWARE** for incorporation into other programs, or modify, reverse-engineer, translate, decompile or otherwise misuse the **SOFTWARE**.

7. The *LICENSEE* agrees that *the ASTI HiQDT Touchscreen Development Team* may hold its contact details in a secure database, which shall be used for the purpose of *SOFTWARE* license administration only.
8. *The ASTI HiQDT Touchscreen Development Team* shall be under no specific obligation to provide assistance of any kind in the installation or application of the *SOFTWARE*. Assistance may be provided as possible on a best faith basis that does not constitute any promise for any particular timeframe or scope of support.
9. The *SOFTWARE* is supplied "as is", without warranty, representation or guarantee of any kind, either expressed or implied, including, but not limited to, any implied warranties of quality, merchantability, fitness for a particular purpose or ability to achieve a particular result. The *LICENSEE* assumes the entire risk as to the quality and performance of the *SOFTWARE*. Should the *SOFTWARE* prove defective, the *LICENSEE* assumes the entire cost of all necessary servicing, repair or correction. *HiQDT Touchscreen Development Team* does not warrant that the *SOFTWARE* will meet the requirements of the *LICENSEE* or the correctness of the code.
10. *HiQDT Touchscreen Development Team* may periodically makes available upgrades to *SOFTWARE* from the *SOFTWARE*. It is the *LICENSEE's* responsibility to keep its copies of the *SOFTWARE* as current as possible to ensure proper operating with any mating smart digital HiQDT sensors.
11. Should the *SOFTWARE* prove defective, the *LICENSEE* should immediately notify *the ASTI HiQDT Touchscreen Development Team* about such defects and provide all the material necessary to reproduce and correct them such as Operating System, sensor and transmitter wiring and other related information as requested by *the ASTI HiQDT Touchscreen Development Team*.
12. *The ASTI HiQDT Touchscreen Development Team* makes no representation or warranty that use of the *SOFTWARE* will not result in the innocent infringement of third-party intellectual property rights. *The ASTI HiQDT Touchscreen Development Team* does not accept any responsibility whatsoever for infringement of such rights.
13. In no event will *the ASTI HiQDT Touchscreen Development Team* be liable for any damages resulting from loss of data or use, lost profits, loss of anticipated savings, nor for any damages that are an indirect or secondary consequence of any act or omission of *the ASTI HiQDT Touchscreen Development Team*, whether such damages were reasonably foreseeable or actually foreseen.
14. **License termination.** The *ASTI HiQDT Touchscreen Development Team* may terminate this license immediately without warning if *LICENSEE* is found to be in breach of any of the terms of this Agreement.
15. On termination of this Agreement the *SOFTWARE* in possession of the *LICENSEE* shall no longer be used.