

Model 3TX-TEM 3-Wire Temperature Transmitter

- 3TX-TEM is a module to add a scalable analog output for Temperature to any 3TX-pH, 3TX-ISE, 3TX-CON or 3TX-DO measurement module
- Input for temperature measurement can be Pt100 or Pt1000 type element
- **Special hardware & software allows a single Pt100/Pt1000 to be used both as input for a 3TX measurement module and a 3TX-TEM temperature transmitter. This configuration is referred to as “spliced” input mode and is the default.**
- **Any pH, ORP, ISE, conductivity or DO sensor with Pt100/Pt1000 in “splice” mode will be used both for temperature compensation on the measurement module and to send a scalable output for temperature from the 3TX-TEM**
- Direct wiring from separate (rather than shared) Pt100 or Pt1000 temperature elements is also supported. This configuration is referred to as “raw” input mode.
- Displays Temperature (°C) and raw Ohms (Ω) from Pt100/Pt1000 element
- Scalable Analog Output 0-20 mA or 4-20 mA for Temperature
- Galvanic isolation between temp input, power & analog output (3000V rating)
- Field installations using weatherproof NEMA 4X & IP65 enclosures for up to 7 ea pH/ORP/ISE/DO or conductivity transmitters in single enclosure assembly

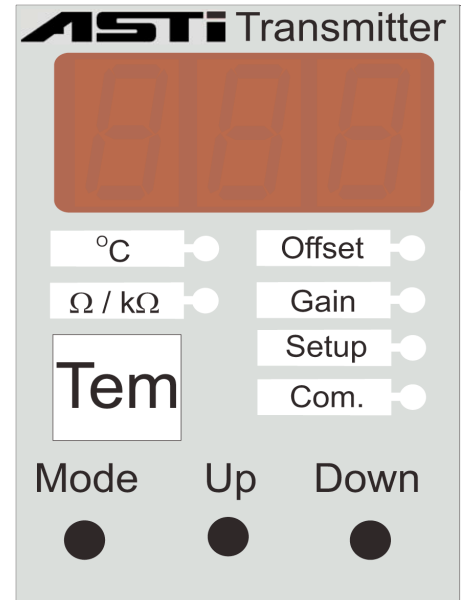

FEATURES

The ASTI 3TX Family of Transmitters Consists Of:

3TX-pH: pH, ORP/mV and Temperature Transmitter with fully scalable 0/4-20mA output and MODbus (optional)

3TX-CON: Contacting Conductivity Transmitter with fully scalable 0/4-20mA output and MODbus (optional)

3TX-ISE: Ion Selective * Transmitter with fully scalable 0/4-20mA output and MODbus (optional)

3TX-DO: Dissolved Oxygen Transmitter with fully scalable 0/4-20mA output and MODbus (optional)

3TX-TEM: Adds scalable 0/4-20mA output of Temperature to 3TX-pH, 3TX-ISE, 3TX-CON or 3TX-DO transmitter.

3TX-REL: Alarm & relay controller (On/Off, TPC, PFC) for pH/ORP, ISE, DO & Conductivity measurement modules

3TX-TOT: Compute pH compensated “Total ISE” from ISE & pH analog inputs, 0/4-20mA analog & MODbus outputs

3TX-DAT: Datalogger & MODbus Master for up to 63 each 3TX transmitter modules with RS485 MODbus output

The 3TX family has a 3 digit display and 6 LEDs for setup and displaying values. The ‘Mode’ key is used to navigate.

Programming

The module is programmed by 3 keys on the front panel. The ‘Mode’ toggles and the ‘Up’ or ‘Down’ scroll through parameters. The parameter is altered via the ‘Mode’ and the value is changed using the ‘Up’ or ‘Down’. **Parameter P01 is a “lock” which must be set to ‘Off’ to change ANY parameter, including the offset and gain calibrations.**

* Ion selective measurement must be validated by ASTI factory prior to order.
3TX-ISE sold only as part of complete ISE system with mating ISE sensor.

Input

The Pt100 or Pt1000 temperature element can be connected either directly (“raw”) or else across a bridged terminal block (“splice”) to the 3TX-TEM transmitter. The measured resistance from these temperature sensors are processed by the microprocessor. Both offset and gain calibrations are supported for the temperature measurement for best accuracy in both raw and spliced wiring input modes. Correction for the resistance owing to the cable is automatically corrected via user entered wire gauge and cable length when in the raw input mode.

Analog Output

The 3TX-TEM transmitter (module) has a scalable analog output of either 0-20 mA or 4-20 mA (selectable). The minimum between the low (0mA or 4mA) and high (20mA) output is 100 °C. The output is proportional to the temperature and is galvanically insulated from the input. Trim calibrations for the 4mA (offset) and 20mA (gain) are available in the setup parameters to ensure accurate analog output anywhere within the scalable output range.

MODbus

No MODbus output is available for the 3TX-TEM transmitter. If MODbus is desired, it is recommended to get the temp measurement via the MODbus output of the pH, ORP, ISE, conductivity or DO measurement module directly. If you require a special version of the 3TX-TEM that supplies both an analog output and a MODbus RS485 output please contact factory for such custom requests.

TECHNICAL SPECIFICATIONS

Mechanical

Housing: Lexan UL94V-0 (Upper part)
Noryl UL94V-0 (Lower part)
Mounting: M36 for 35 mm DIN rail
IP Class: Housing IP40. Connector IP20
Connector: Max 16A. Max 2.5 mm²
Max torque 0,6 Nm
Temp.: Usage -15 to +50 °C (Storage -35 to +75 °C)
Weight: 200 grams (7.05 ounces)
Dimensions: D 58 x W 36 x H 86 mm (2.3" X 1.4" X 3.4")

Electrical

Power Supply: 24VDC ±10%
Consumption: 60 mA max
Accuracy: ±0.2% Excluding Sensor (Ideal)
Temp Sensor: Pt100, Pt1000
Temp Range: 0-210°C ± 0.2°C
Analog Output: 0-20mA or 4-20mA, max. 500Ω
CE mark: EN61326A



PARAMETERS

Function and Programming

The 13 programmable parameters are shown to the right. For access see the paragraph about programming on page 1.

If the softwarelock (Par. no. 1) is "On" the parameter can only be read. Set Software Lock to "Off" to change values.

- Par. no. 2** sets the type of wiring used as splice or raw (direct).
- Par. no. 3** sets the temperature element to be Pt100 or Pt1000 type.
- Par. no. 4** set the wire gauge (AWG) for the sensor cable used
- Par. no. 5** sets the length of sensor cable in units of feet.
- Par. no. 6** sets the analog output to either 0-20 mA or 4-20 mA.
- Par. no. 7** allows setting the output to be inverted (i.e. for use in control) with the output corresponding to 20-0mA or 20-4mA.
- Par. no. 08 & 09** are used to set the temperature value that corresponds to 0/4mA output setpoint (**Par no. 08**) and sets the temperature value that corresponds to 20mA output setpoint (**Par no. 09**). The minimum difference between Par no. 08 and 09 must be at least 100 °C, although it is fully scalable within the range.
- Par. no. 10** Offset adjustment for 4mA low analog output trim.
- Par. no. 11** Gain adjustment for 20mA high analog output trim.
- Par. no. 12** If no keys are pressed for 10 minutes the display will show a flashing bar (Energy Save). Pressing any key to return.
- Par. no. 13** Feature to reset the analyzer back to factory default.

* Negative trim adjustments will be shown as flashing numbers.

List of Parameters

No	Parameter	Description	Range	Default
P01	Lock	Software Lock	On / Off	On
P02	Temp Mode	Wiring Type	Splice, Raw	Splice
P03	TC Input Select	Select the Pt Input Type	Pt100 or Pt1000	Pt1000
P04	Wire Gauge	Sensor Lead AWG	20, 22, 24	24
P05	Cable Length	Length of cable in feet	1...999 feet	10
P06	Type of Output	Select 0-20mA or 4-20mA	4-20mA, 0-20mA	4-20mA
P07	Output Mode	Analog Output Mode	Non-inverted, Inverted	n.inv
P08	0/4mA Low Output Setpoint	Reading @ 0/4mA	0 to 100 °C	0
P09	20mA High Output Setpoint	Reading @ 20 mA	100 to 210 °C	210
P10	Trim Low Output	4mA Offset Cal for Output	± 9.99% *	Factory Cal
P11	Trim High Output	20mA Gain Cal for Output	± 9.99% *	Factory Cal
P12	Energy Save	Energy Save	On / Off	On
P13	Back to Default	Reset to Default	Def=Reset, Par=No Reset	Par

CALIBRATION PROCEDURES

For Splice Type Wiring

Step 1:
Obtain a valid variable resistor potentiometer (a.k.a. "turn-pot") with a nominal value of 200 Ohms if a Pt100 element is used and a nominal value of 2000 Ohms if a Pt1000 element is used. Wire-up the turn-pot as "splice" type input as shown on page 3 to serve as a simulated temperature sensor.

Step 2:
Adjust the turn-pot so that the temperature reading on the measurement module (3TX-Aux) is very close to 0.0°C. Use the 'Offset' calibration mode to make the 3TX-TEM temperature (°C) reading agree with what is shown on the 3TX-Aux (measurement) module.

Step 3:
Adjust the turn-pot so that the temperature reading on the measurement module (3TX-Aux) is very close to 210°C. Use the 'Gain' calibration mode to make the 3TX-TEM temperature (°C) reading agree with what is shown on the 3TX-Aux (measurement) module.

For Raw (Direct) Type Wiring

Step 1:
Obtain a valid variable resistor potentiometer (a.k.a. "turn-pot") with a nominal value of 200 Ohms if a Pt100 element is used and a nominal value of 2000 Ohms if a Pt1000 element is used. Wire-up the turn-pot as "raw" type input as shown on page 3 to serve as a simulated temperature sensor.

Step 2:
Adjust the turn-pot so that the temperature reading on 3TX-TEM is very close to 0.0°C. Use the 'Offset' calibration mode to make the 3TX-TEM reading agree with nominal temperature (°C) for that resistance. Adjust the turn-pot so that the temperature reading on 3TX-TEM is very close to 210°C. Use the 'Gain' calibration mode to make the 3TX-TEM reading agree with nominal temperature (°C) for that resistance.

Step 3:
Determine the wire gauge and cable length of your Pt100 or Pt1000 temperature sensor and enter this into parameters P04 & P05, respectively. This corrects for any impact on temp due to resistance from cable length.

Typical Splice Type Wiring

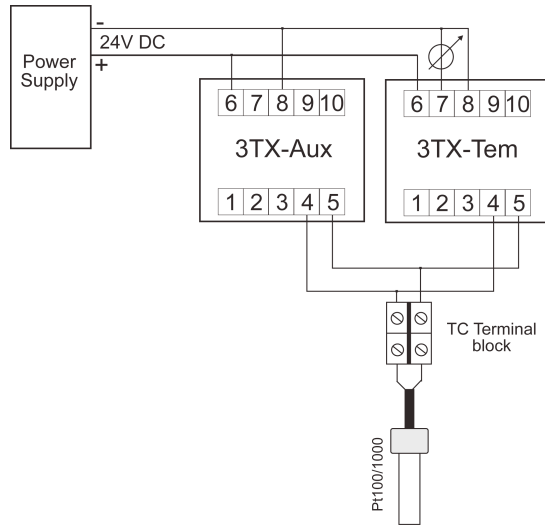

Typical Raw (Direct) Type Wiring

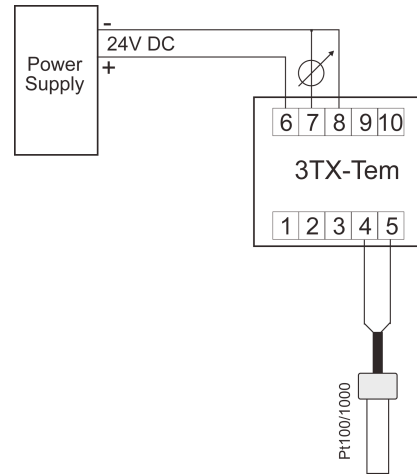

SPLICE WIRING NOTES:

1. Wiring schematic valid when parameter P01 is splice.
2. The wiring schematic above is valid when the mating 3TX-Aux module is any 3TX-pH, 3TX-ISE, 3TX-CON or 3TX-DO measurement transmitter.
3. Be sure to select whether a Pt100 or Pt1000 is used in parameter P03. This will be the type of TC element in your pH/ORP/ISE/Conductivity or DO sensor. Only the temperature portion of the wiring is shown for simplicity.

RAW WIRING NOTES:

1. Wiring schematic valid when parameter P01 is raw (direct).
2. Be sure to correctly input the wire gauge (P04) and cable length (P05) when in this raw (direct) temperature input mode. Parameters P04 & P05 are used to compute the resistance due to the sensor cable length and automatically correct for this contribution. This correction is only active in raw input mode (and altogether disabled in splice mode).

Sample Nominal (Approximate) Pt100 & Pt1000 Resistance & Temperature Tables

°C	Ω	°C	Ω	°C	Ω	°C	Ω
0	100	38	115	76	129	114	144
2	101	40	116	78	130	116	145
4	102	42	116	80	131	118	145
6	102	44	117	82	132	120	146
8	103	46	118	84	132	122	147
10	104	48	119	86	133	124	148
12	105	50	119	88	134	126	148
14	105	52	120	90	135	128	149
16	106	54	121	92	135	130	150
18	107	56	122	94	136	132	151
20	108	58	122	96	137	134	151
22	109	60	123	98	138	136	152
24	109	62	124	100	139	138	153
26	110	64	125	102	139	140	154
28	111	66	126	104	140	142	154
30	112	68	126	106	141	144	155
32	112	70	127	108	142	146	156
34	113	72	128	110	142	148	157
36	114	74	129	112	143	150	157

°C	kΩ	°C	kΩ	°C	kΩ	°C	kΩ	°C	kΩ	°C	kΩ
0	1.00	38	1.15	76	1.29	114	1.44	152	1.58	190	1.72
2	1.01	40	1.16	78	1.30	116	1.45	154	1.59	192	1.73
4	1.02	42	1.16	80	1.31	118	1.45	156	1.60	194	1.74
6	1.02	44	1.17	82	1.32	120	1.46	158	1.60	196	1.74
8	1.03	46	1.18	84	1.32	122	1.47	160	1.61	198	1.75
10	1.04	48	1.19	86	1.33	124	1.48	162	1.62	200	1.76
12	1.05	50	1.19	88	1.34	126	1.48	164	1.63	202	1.77
14	1.05	52	1.20	90	1.35	128	1.49	166	1.63	204	1.77
16	1.06	54	1.21	92	1.35	130	1.50	168	1.64	206	1.78
18	1.07	56	1.22	94	1.36	132	1.51	170	1.65	208	1.79
20	1.08	58	1.22	96	1.37	134	1.51	172	1.66	210	1.80
22	1.09	60	1.23	98	1.38	136	1.52	174	1.66		
24	1.09	62	1.24	100	1.39	138	1.53	176	1.67		
26	1.10	64	1.25	102	1.39	140	1.54	178	1.68		
28	1.11	66	1.26	104	1.40	142	1.54	180	1.68		
30	1.12	68	1.26	106	1.41	144	1.55	182	1.69		
32	1.12	70	1.27	108	1.42	146	1.56	184	1.70		
34	1.13	72	1.28	110	1.42	148	1.57	186	1.71		
36	1.14	74	1.29	112	1.43	150	1.57	188	1.71		

NOTE: The raw (uncalibrated) resistance of the Pt100 or Pt1000 type temperature element can be viewed in the "Ω / kΩ" LED mode.



ORDERING INFORMATION FOR 3TX FAMILY OF TRANSMITTERS

ENCLOSURE TYPE	
CODE	DESCRIPTION
3TX-0M	3TX Transmitter with No Enclosure
3TX-DIN	3TX Transmitter with No Enclosure; Preinstalled onto 35mm DIN-Rail
3TX-2MW	3TX Transmitter(s) with IP65 WeatherProof Enclosure; Up to 2 Total Modules (Wall Installations Only)
3TX-2M	3TX Transmitter(s) with IP65 WeatherProof Enclosure; Up to 2 Total Modules (Wall or Pipe Installations)
3TX-3MP	3TX Transmitter(s) with NEMA 4X Enclosure for ½-DIN Panel Only ; Up to 3 Modules (with Panel Bracket Assembly)
3TX-3MF	3TX Transmitter(s) with NEMA 4X Enclosure; Up to 3 Total Modules (Wall or Pipe Installations)
3TX-4MW	3TX Transmitter(s) with IP65 WeatherProof Enclosure; Up to 4 Total Modules (Wall Installations Only)
3TX-4M	3TX Transmitter(s) with IP65 WeatherProof Enclosure; Up to 4 Total Modules (Wall or Pipe Installations)
3TX-6M ***	3TX Transmitter(s) with IP65 WeatherProof Enclosure; Up to 6 Total Modules (Wall or Pipe Installations)
3TX-7MF ***	3TX Transmitter(s) with NEMA 4X Enclosure; Up to 7 Total Modules (Wall or Pipe Installations)
3TX-9MF ***	3TX Transmitter(s) with NEMA 4X Enclosure; Up to 9 Total Modules (Wall or Pipe Installations)
MEASUREMENT MODULES ONE (1) THROUGH SEVEN (7)	
CODE	DESCRIPTION
-pH **	pH/ORP/mV/Temp Measurement Module / Transmitter
-HiQ-pH	Intelligent pH & ORP Transmitter for Smart Digital pH & ORP Sensors; Both 4-20mA & MODBUS outputs standard
-CON-CELL/RANGE	Contacting Conductivity Measurement Module / Transmitter (CELL Constant & RANGE in mS Defined at Time of Order)
-ISE-ION **	Ion Selective (ISE) Measurement Module / Transmitter (Ion Measurement Type ION must be Defined at Time of Order) *
-DO **	Dissolved Oxygen Measurement Module / Transmitter For Galvanic Type DO sensors
OUTPUT OPTIONS FOR ANALOG MEASUREMENT MODULES (ONE OPTION MUST BE SELECTED FOR EACH MODULE)	
CODE	DESCRIPTION
-A	Single Fully Scalable Analog 0-20 or 4-20 mA Output Only
-D	Single Fully Scalable Analog 0-20 or 4-20 mA Output Only AND RS-485 MODbus Digital Output
ADD-ON MODULES FOR MEASUREMENT MODULE ENCLOSURE ASSEMBLIES	
CODE	DESCRIPTION
-PS	100 to 240 VAC 50/60 Hz Universal Power Supply Adapter for Line Powered Operation
-PS/BAT	Dual Isolated & Regulated 24VDC Power Supply Step-Up Converter for operation from 5V, 6V & 9V Batteries
-TEM	Scalable Analog 0-20 or 4-20mA Temperature Transmitter for Raw or Spliced Pt100/Pt1000 temperature element
-SW	On/Off Power Switch (½ Width of power supply module and ¼ width of standard 3TX transmitter)
-REL	Alarm and Relay Controller Module for 3TX-pH, 3TX-ISE, 3TX-CON and 3TX-DO measurement modules
-TOT	Compute pH compensated "Total ISE" from analog inputs for ISE & pH, 0/4-20mA analog & MODbus digital outputs
-DAT	Datalogger & MODbusmaster for 3TX Transmitters with RS485 MODbus; Download & Setup via RS232/USB on Windows

Contact the factory for specific recommendations & ALL ISE inquiries. Pipe mounting bracket kits supplied separately. For 3MP, 3MF, 6M & 7MF enclosures power supply is not counted as a module for space purposes.

Model: 3TX-2M-pH-A-CON-1.0/50-D

Description: Dual Channel Transmitter Assy w/ Weatherproof Enclosure (2 Total Modules); 1 each pH Measurement w/ Analog Output; 1 each Contacting Conductivity Measurement w/ Cell Constant 1.0/cm & Full Range 0-50mS/cm (Min Scaling 0-5.0mS/cm); with Analog and Digital MODbus RS-485 Outputs (No AC Power Supply)

Model: 3TX-3MP-ISE-F-A-pH-A-TOT-PS

Description: Dual Channel Total Fluoride Measurement Transmitter Assembly with NEMA 4X (UL) Enclosure for ½-DIN Panel Mounting Installations (for 3 Total Modules); 1 each ISE Fluoride Ion and 1 each pH Measurement Module with Analog Output Only; 1 each TOT module to compute total fluoride (HF + F-) with Analog & MODbus Outputs for all free fluoride, pH and temperature; With Universal 11 Power Supply Module

Model: 3TX-3MF-DO-D-TEM-SW-PS

Description: Dissolve Oxygen Transmitter Assembly with NEMA 4X CSA/UL rated Enclosure; Field or Wall Mounting Installations (3 Module Max); 1 each DO transmitter for galvanic type dissolved oxygen sensors; Scalable Analog & MODbus Output for DO ppm, saturation & Temperature; 115/230 Power Supply with On/Off Switch

Model: 3TX-4MW-ISE-NH4-A-pH-A-TOT-PS

Description: Dual Channel Total Ammonia Measurement Transmitter Assembly; Weatherproof Wall Mount Only Enclosure (4 Modules Max); 1 each ISE Ammonium Ion and 1 each pH Measurement Module with Analog Output Only; 1 each TOT to compute total ammonia (NH₃) with Analog & MODbus Outputs; With 115/230 Power Supply

Model: 3TX-6M-ISE-NH4-A-pH-A-TOT-ISE-NO2-A-pH-D-DO-D-PS

Description: Five Channel Transmitter Assembly with Weatherproof Enclosure (for 6 Total Modules); 1 each ISE Ammonium Ion and 1 each pH Measurement Module with Analog Output Only; 1 each TOT module to compute total ammonia (NH₃) with Analog & MODbus Outputs; 1 each ISE Nitrite Ion with Analog Output Only; 1 each ORP Measurement Module and 1 each DO transmitter for galvanic active self-polarizing type sensors both with Scalable Analog & MODbus Outputs; With 115/230 Power Supply

Model: 3TX-6M-ISE-X-F-D-REL-pH-X-D-REL-CON-10.0/500-D-DAT-PS

Description: Triple Channel Transmitter Assembly with Weatherproof Enclosure (for 6 Total Modules Max); 1 each Preamp Style Fluoride ISE Measurement Module & 1 each Preamp Style pH Measurement Module with Alarm/Relay Controller for both Fluoride ISE & pH; 1 each Contacting Conductivity Measurement with K=10.0/cm & Full Range 0-500mS; Analog & MODbus Outputs for All Measurements; DAT Datalogger/MODbusmaster Module to record all parameters; Universal 115/230 Power Supply

Model: 3TX-7MF-ISE-NH4-D-ISE-NO3-D-ISE-NO2-D-pH-D-CON-1.0/50-D-DO-D-DAT

Description: Six Channel Measuring Transmitter Assembly Optimized for Low-Power Battery Operation; with NEMA 4X CSA/UL rated Enclosure (7 Module Max); 1 each ISE Ammonium Ion, 1 each ISE Nitrate Ion and 1 each ISE Nitrite Ion Module; 1 each pH module; 1 each Contacting Conductivity K= 1.0/cm & Full Range 0-50mS; 1 each Dissolved Oxygen module; Analog & MODbus Outputs for all Measurements & Temp; DAT Datalogger/MODbusmaster for continuous datalogging of all parameters

** For sensors with integral preamplifiers, order the pH/ORP transmitters as -pH-X and the ion selective (ISE) transmitters as -ISE-X and dissolved oxygen (DO) transmitters as -DO-X

*** For 2" NPT pipe mounting installations, an additional adapter plate must also be ordered for the 6M, 7MF & 9MF enclosures (inquire to factory for details).